

- (FR)** NOTICE DE MONTAGE
- (EN)** ASSEMBLY INSTRUCTIONS
- (DE)** MONTAGEANLEITUNG
- (ES)** INSTRUCCIONES DE MONTAJE
- (NL)** MONTAGEVOORSCHRIFT
- (IT)** ISTRUZIONI DI MONTAGGIO
- (PT)** INSTRUÇÕES DE MONTAGEM
- (PL)** INSTRUKCJA MONTAŻU
- (CR)** NAPUTCI ZA MONTAŽU

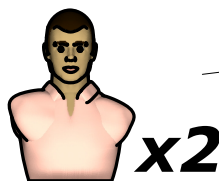

167407

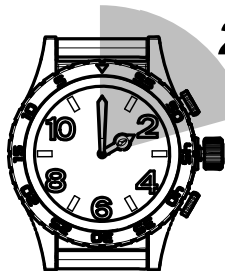
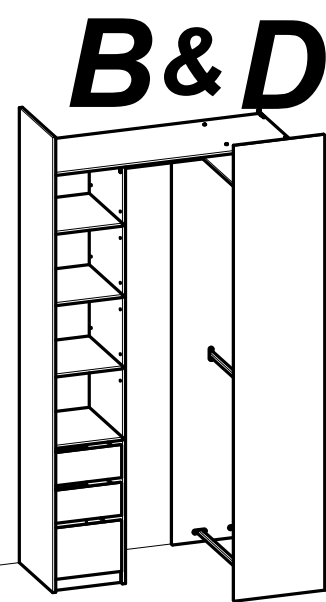
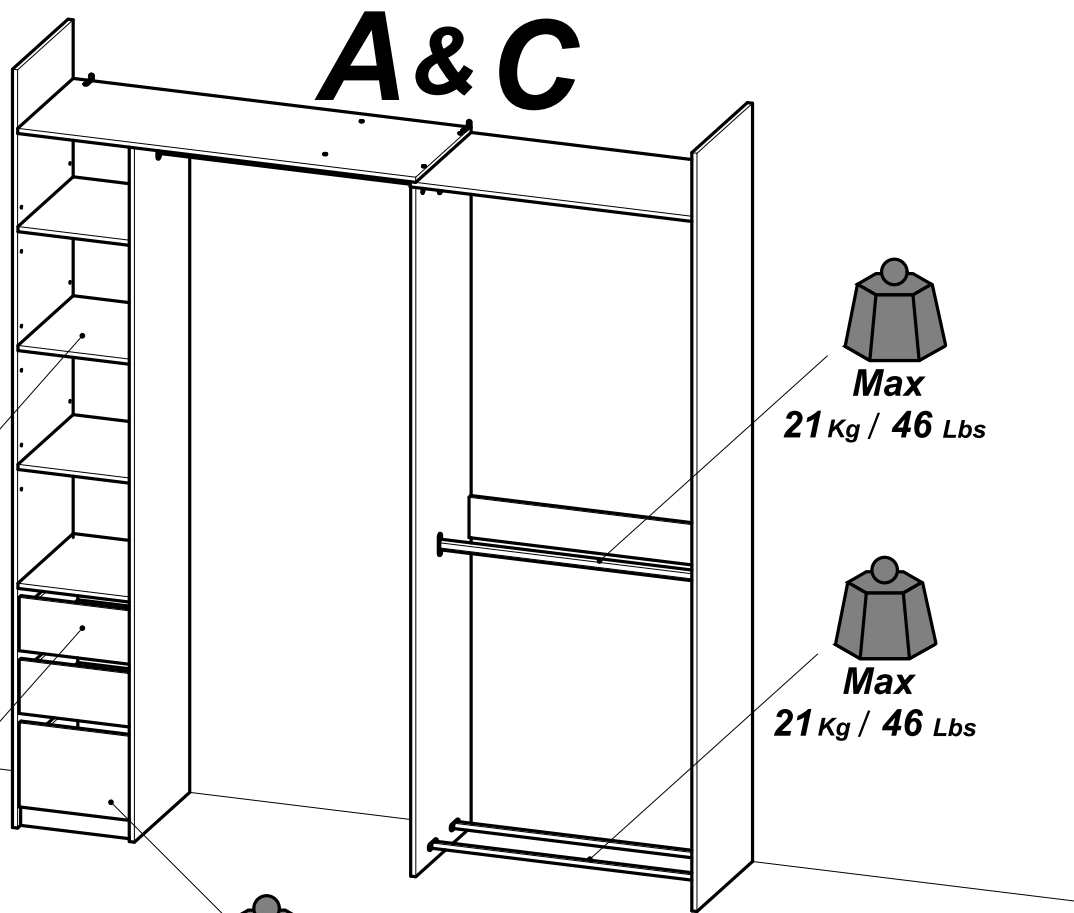
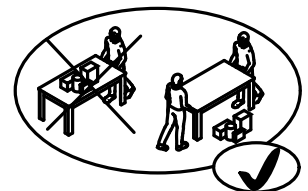
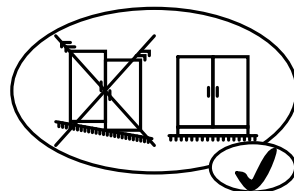
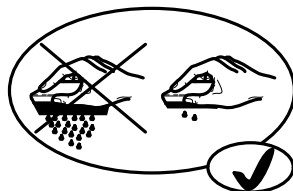
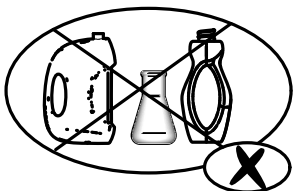
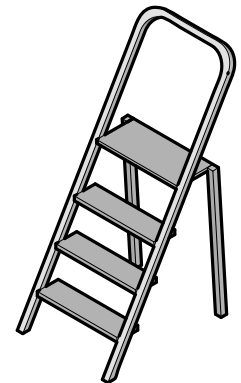
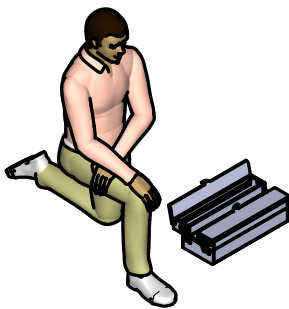
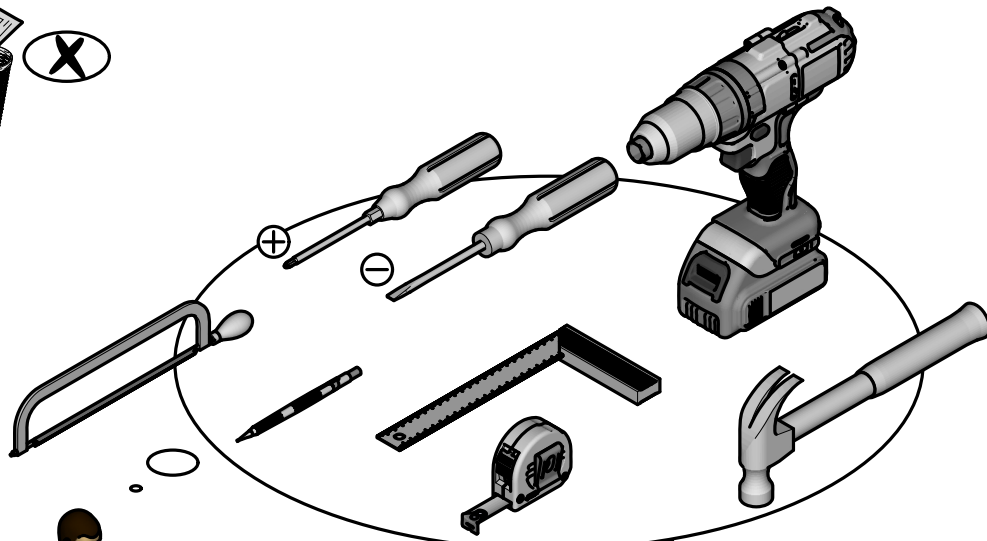
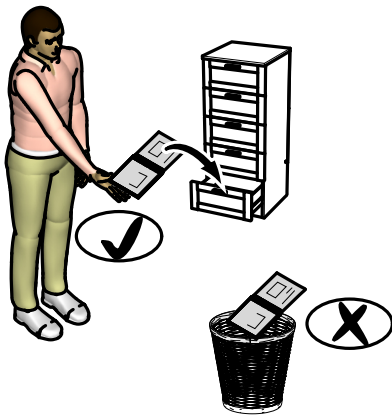
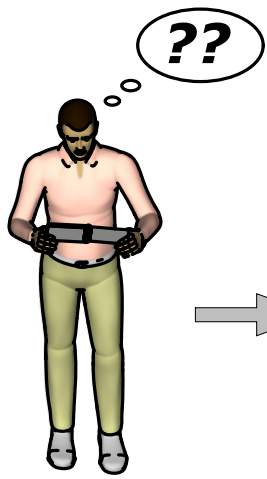

Donnez ou recyclez vos meubles.



Association

ou



Magasin

ou



Déchèterie

<https://www.demeysere.com/fr>



A x26



B x20



C x3

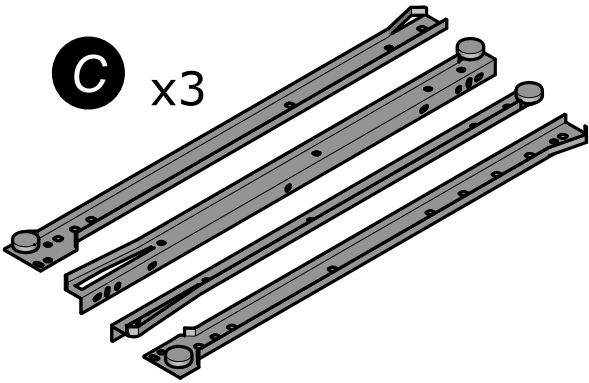

D x3



E x12



F x14

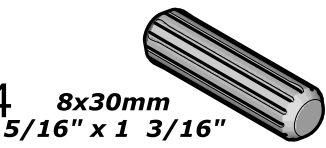

G x4

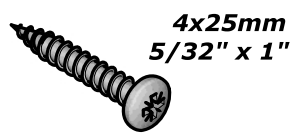

H x18

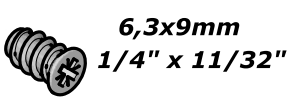

I x18

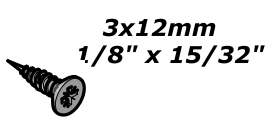

J x23

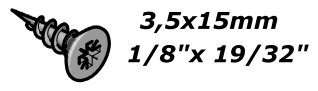

K x5

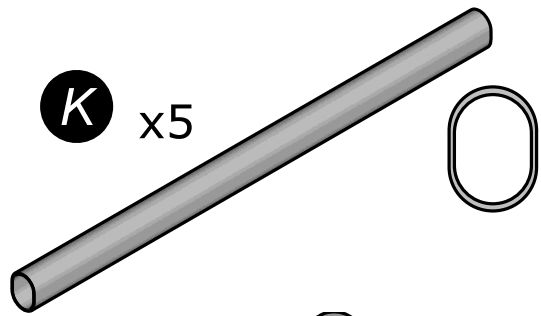

L x10

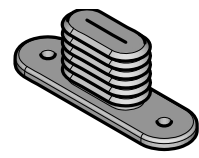

M x1

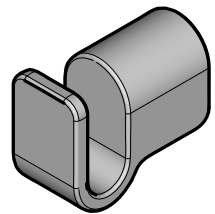

N x1

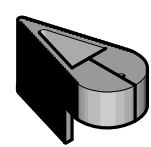

O x3

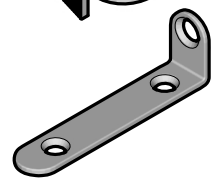

P x12

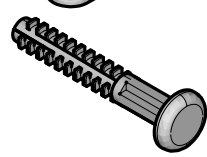

Q x6

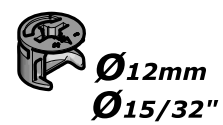

R x1

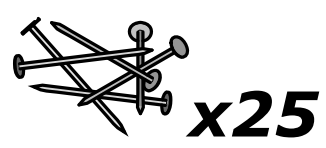

S x3

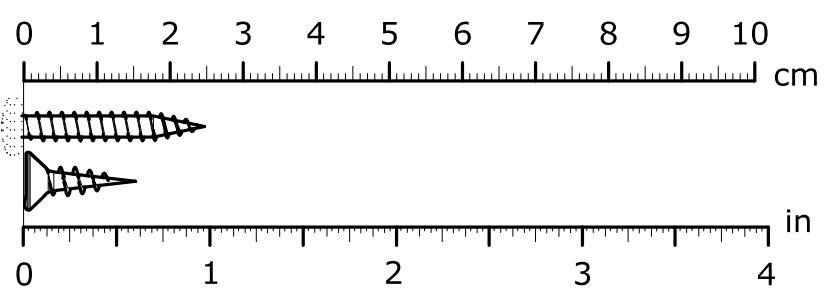
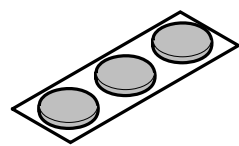

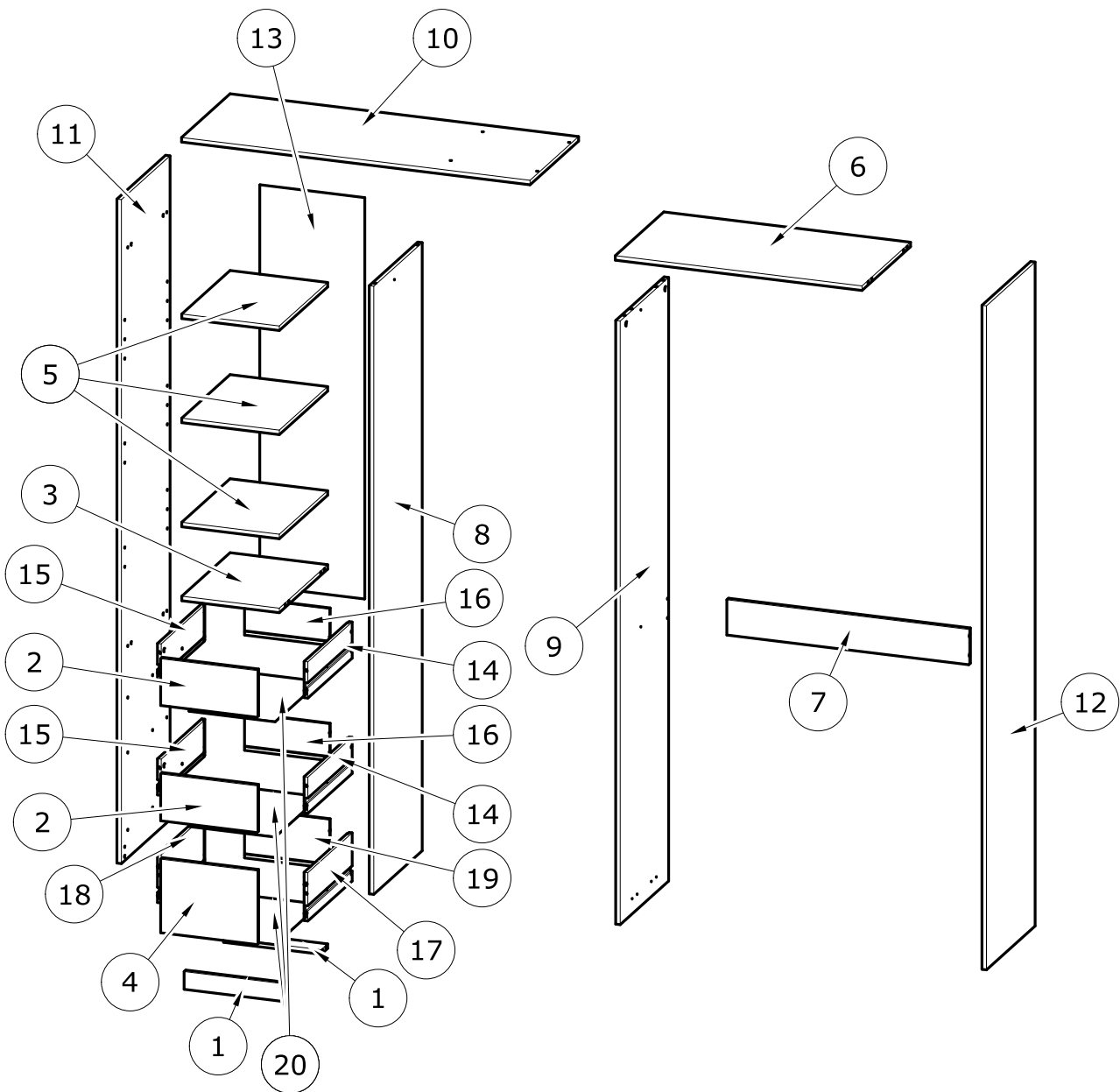

N°	MM		INCH		QTY
1	325	x 59	12 13/16	x 2 5/16	2
2	321	x 155	12 10/16	x 6 2/16	2
3	325	x 436	12 13/16	x 17 3/16	1
4	321	x 244	12 10/16	x 9 10/16	1
5	325	x 436	12 13/16	x 17 3/16	3
6	822	x 438	32 6/16	x 17 4/16	1
7	806	x 117	31 12/16	x 4 10/16	1
8	2 030	x 437	79 15/16	x 17 3/16	1
9	2 015	x 437	79 5/16	x 17 3/16	1
10	1 161	x 438	45 11/16	x 17 4/16	1

N°	MM		INCH		QTY
11	2 183	x 439	85 15/16	x 17 5/16	1
12	2 183	x 439	85 15/16	x 17 5/16	1
13	1 344	x 349	52 15/16	x 13 12/16	1
14	400	x 120	15 12/16	x 4 12/16	2
15	400	x 120	15 12/16	x 4 12/16	2
16	281	x 120	11 1/16	x 4 12/16	2
17	400	x 160	15 12/16	x 6 5/16	1
18	400	x 160	15 12/16	x 6 5/16	1
19	281	x 160	11 1/16	x 6 5/16	1
20	398	x 287	15 11/16	x 11 5/16	3

FR

AVERTISSEMENT : MEUBLE A FIXER IMPERATIVEMENT AU MUR AFIN D'EVITER SON BASCULEMENT

- Pour installer correctement ce produit et éliminer les risques pour votre sécurité, merci de suivre exactement ce manuel d'instruction.
- Fixer le meuble au mur avec les attaches prévues à cet effet
- Les vis et les chevilles ne sont pas fournies. Utiliser des vis et des chevilles adaptées au support.

EN

WARNING: FURNITURE TO BE ATTACHED TO THE WALL TO PREVENT OVERTURNING

- Installation shall be carried out exactly according to those instructions-otherwise a safety risk can occur if incorrectly installed;
- Attach the furniture to the wall with the fastening provided for this purpose
- Screw and Pegs are not supplied. Use Screws and pegs adapted to the support.

DE

WARNUNG: DAS MÖBEL MUSS AN DER WAND BEFESTIGT WERDEN, UM ZU VERHINDEN DASS ES KIPPT

- Um das Produkt korrekt zu installieren und um Risiken für Ihre Sicherheit zu verhindern, die Gebrauchsanleitung genauestens befolgen.
- Das Möbel mit den vorgesehenen Befestigungen an einer Wand befestigen.
- Schrauben und Dübel sind nicht im Lieferumfang enthalten. Passende Schrauben und Dübel verwenden.

ES

ADVERTENCIA: ESTE MUEBLE DEBE ESTAR SIEMPRE FIJO EN LA PARED PARA EVITAR QUE VUELQUE

- Para instalar correctamente este producto y eliminar los riesgos para la seguridad, seguir exactamente las instrucciones del manual.
- Fijar el mueble a la pared con las sujeciones previstas a este efecto.
- Los tornillos y los tacos no están incluidos. Utilizar tornillos y tacos adaptados al soporte.

NL

WAARSCHUWING: MEUBEL MOET VERPLICHT AAN DE MUUR BEVESTIGD WORDEN ZODAT HET NIET KAN OMVALLEN

- Om dit product correct te installeren en alle risico's voor uw veiligheid te elimineren, gelieve de instructies in deze handleiding nauwgezet op te volgen.
- Zet het meubel vast aan de muur met de hiertoe voorziene bevestigingen.
- De schroeven en pluggen zijn niet meegeleverd. Gebruik schroeven en pluggen die geschikt zijn voor het materiaal van de muur.

IT

AVVERTENZA: MOBILE DA FISSARE IMPERATIVAMENTE AL MURO PER EVITARE CHE SI RIBALTI

- Per installare correttamente questo prodotto ed eliminare i rischi per la vostra sicurezza, si prega di seguire esattamente il manuale d'istruzioni.
- Fissare il mobile al muro con gli appositi ganci.
- Le viti e i tasselli non sono forniti. Utilizzare viti e tasselli adatti al supporto.

PT

ADVERTÊNCIA: MÓVEL A FIXAR OBRIGATORIAMENTE À PAREDE PARA EVITAR A SUA QUEDA

- Para instalar corretamente este produto e eliminar os riscos para a sua segurança, é favor seguir exatamente este manual de instruções.
- Fixe o móvel à parede com as fixações previstas para o efeito
- Os parafusos e as cavilhas não são fornecidos. Utilize parafusos e cavilhas adaptados ao suporte.

PL

OSTRZEŻENIE: MEBEL NALEŻY PRZYMOCOWAĆ DO ŚCIANY, ABY UNIKNĄĆ JEGO PRZEWRÓCENIA

- Aby prawidłowo zainstalować ten produkt i wyeliminować zagrożenie dla bezpieczeństwa użytkownika, należy postępować zgodnie z niniejszą instrukcją.
- Przymocować mebel do ściany za pomocą mocowań przewidzianych w tym celu.
- Śruby i nakrętki nie znajdują się w zestawie. Użyć śrub i nakrętek dostosowanych do wspornika.

CR

UPOZORENJE : UČVRSTITE ORMARIĆ NA ZID KAKO BISTE SPRIJEČILI NJEGOVO LJULJANJE

- Kako biste pravilno postavili ovaj proizvod i uklonili sigurnosne rizike kojima se izlažete, pridržavajte se strogo ovog priručnika s uputama.
- Postavite ormarić na zid pripadajućim sponama.Vijci i svornjci ne isporučuju se. Upotrijebite nosne vijke i svornjke.

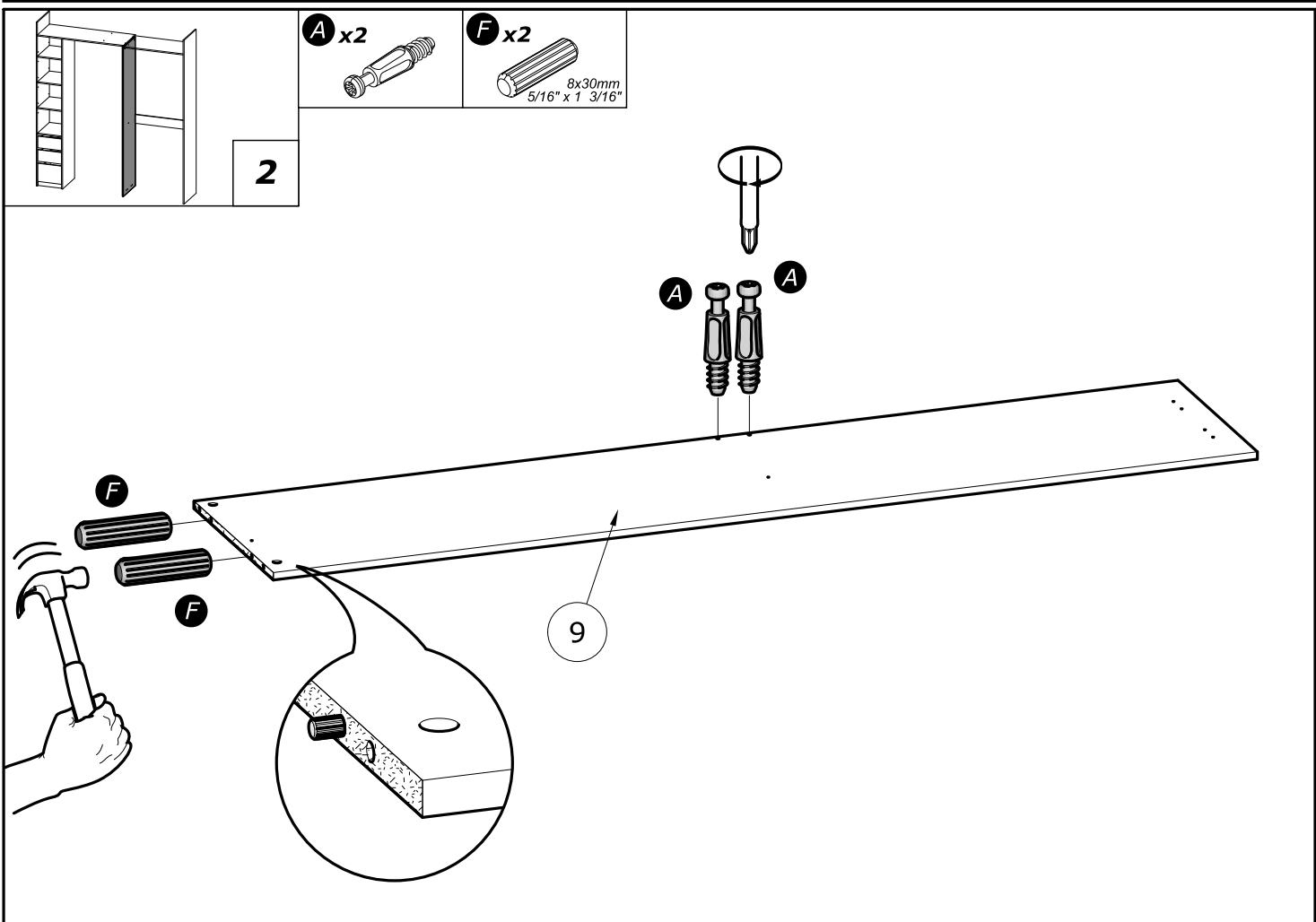
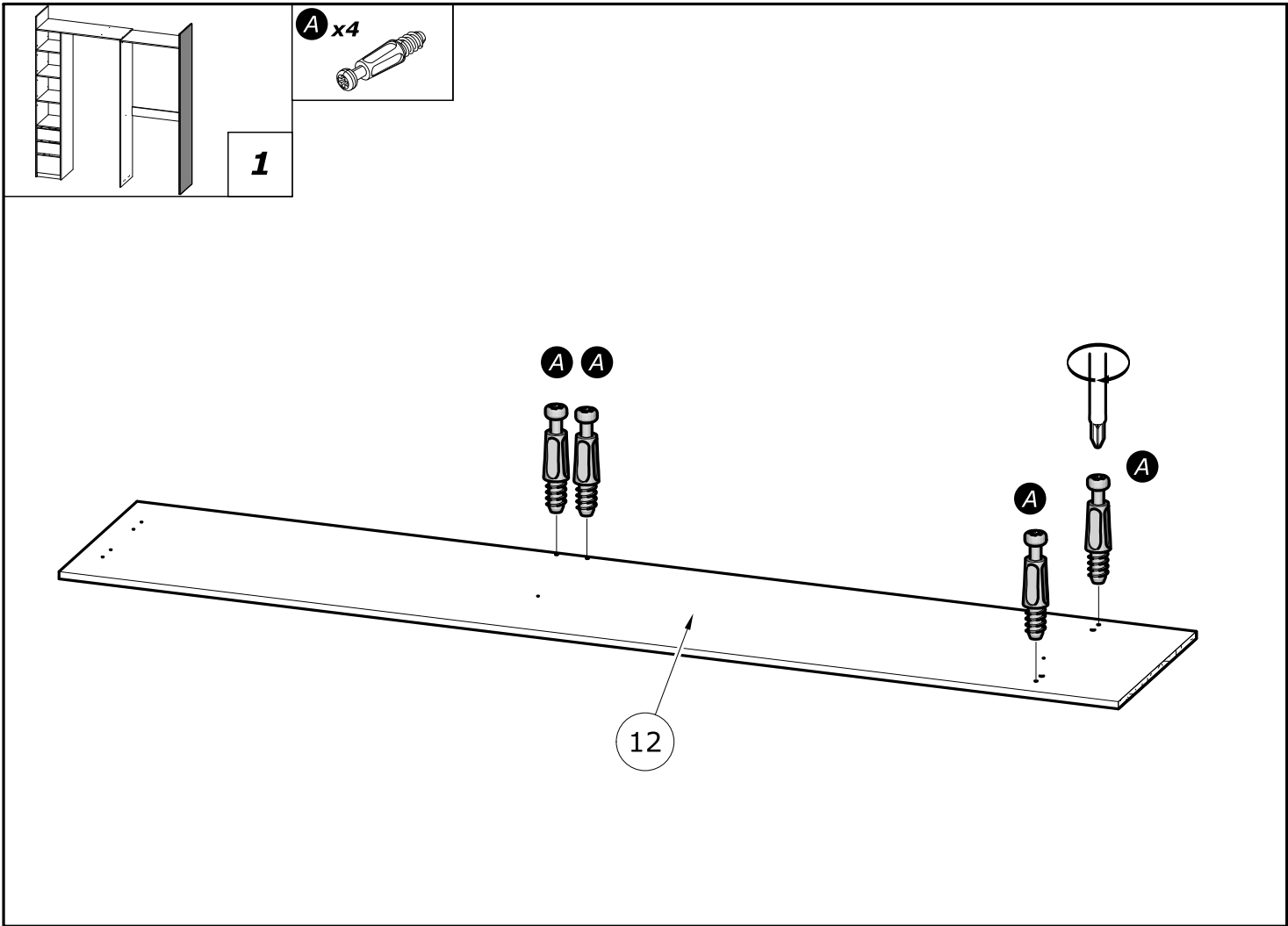

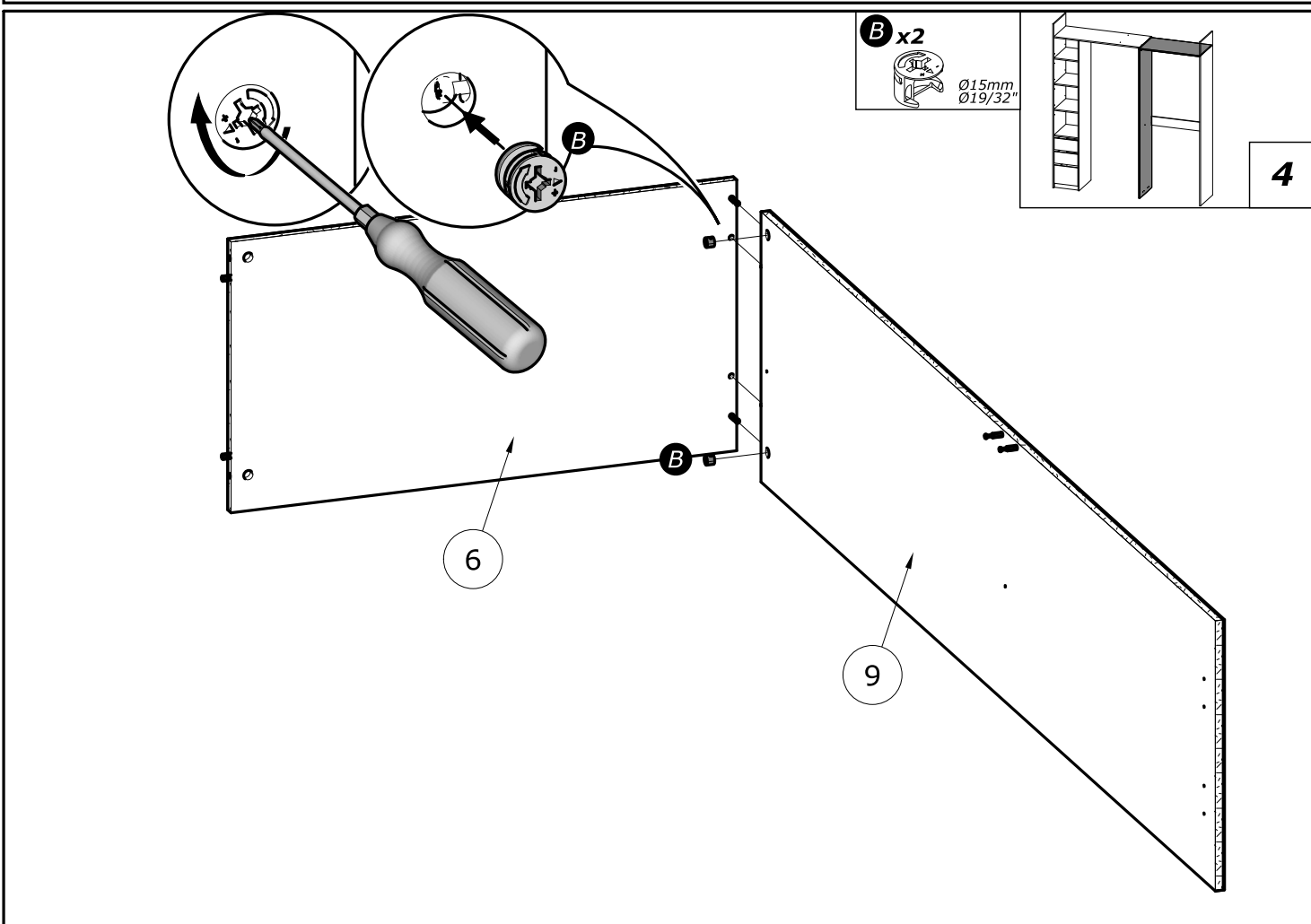
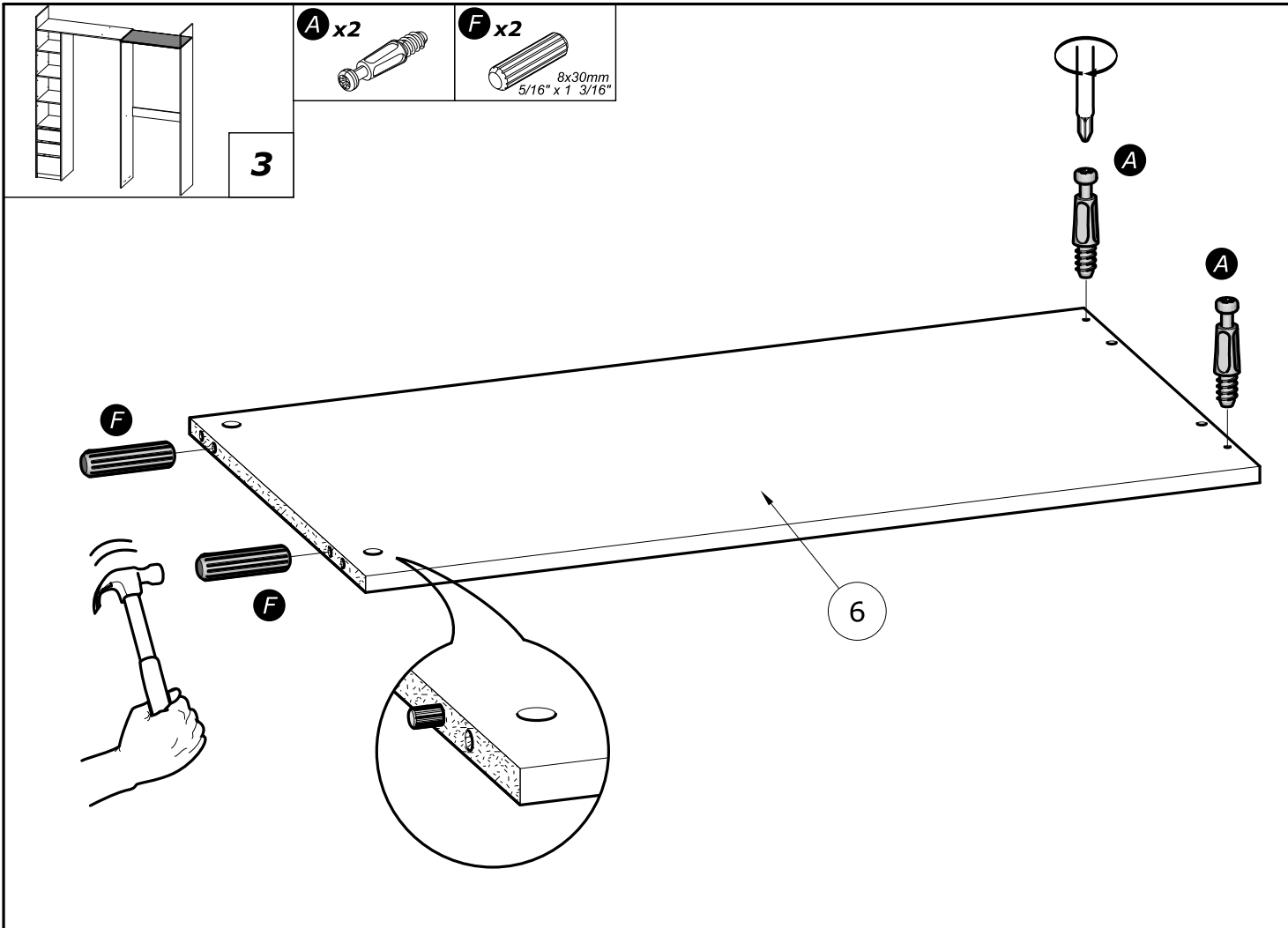

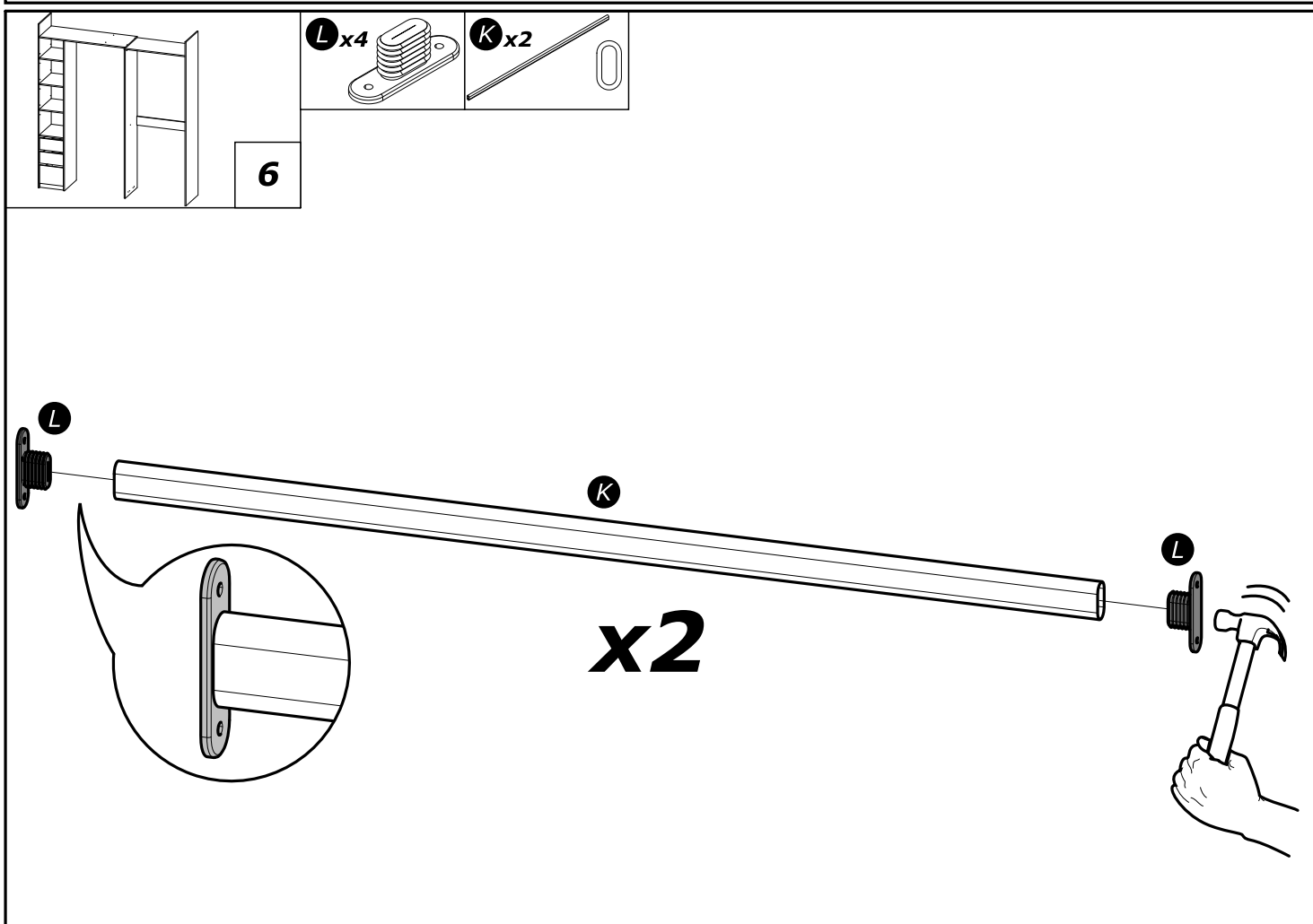
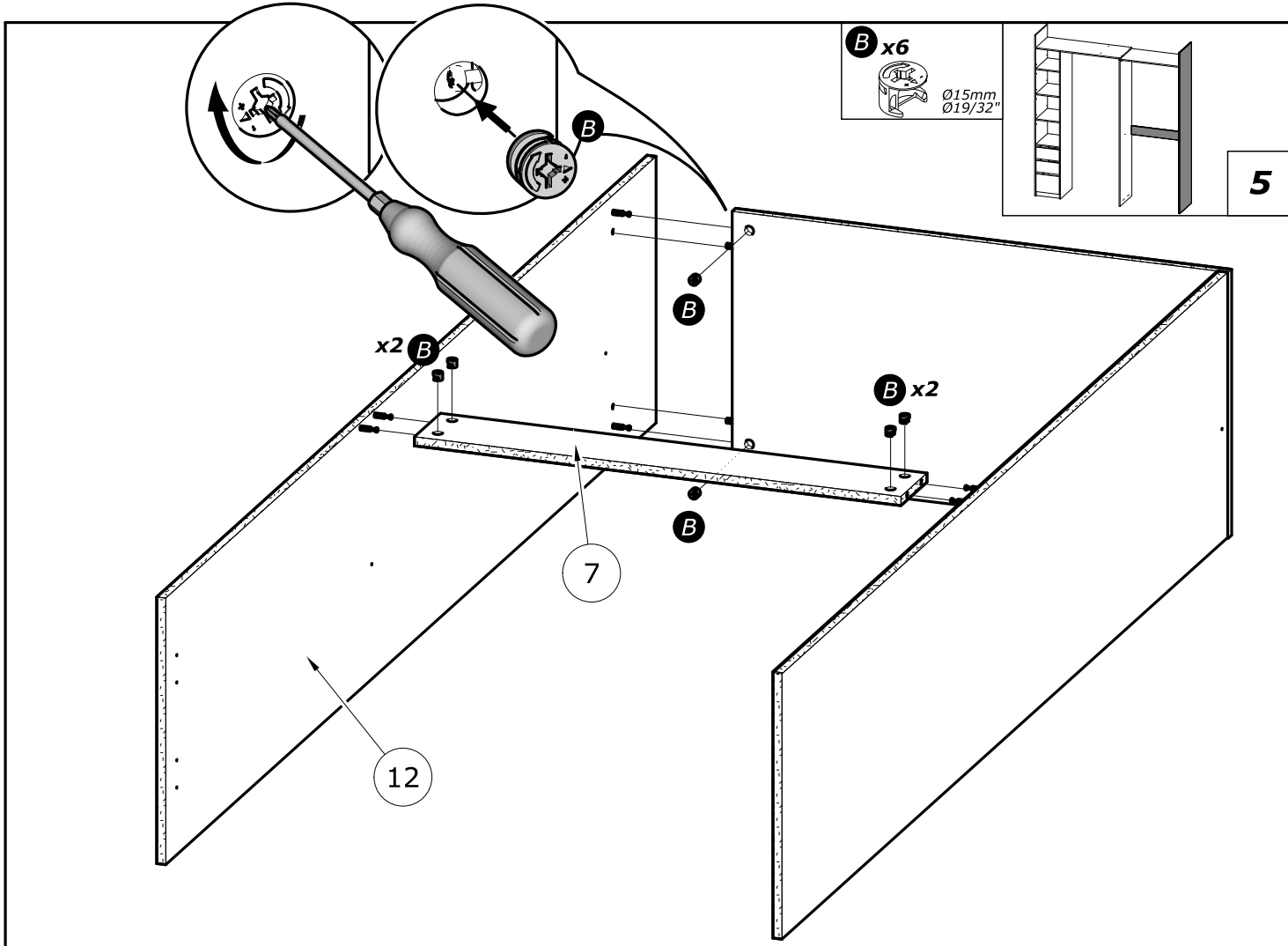

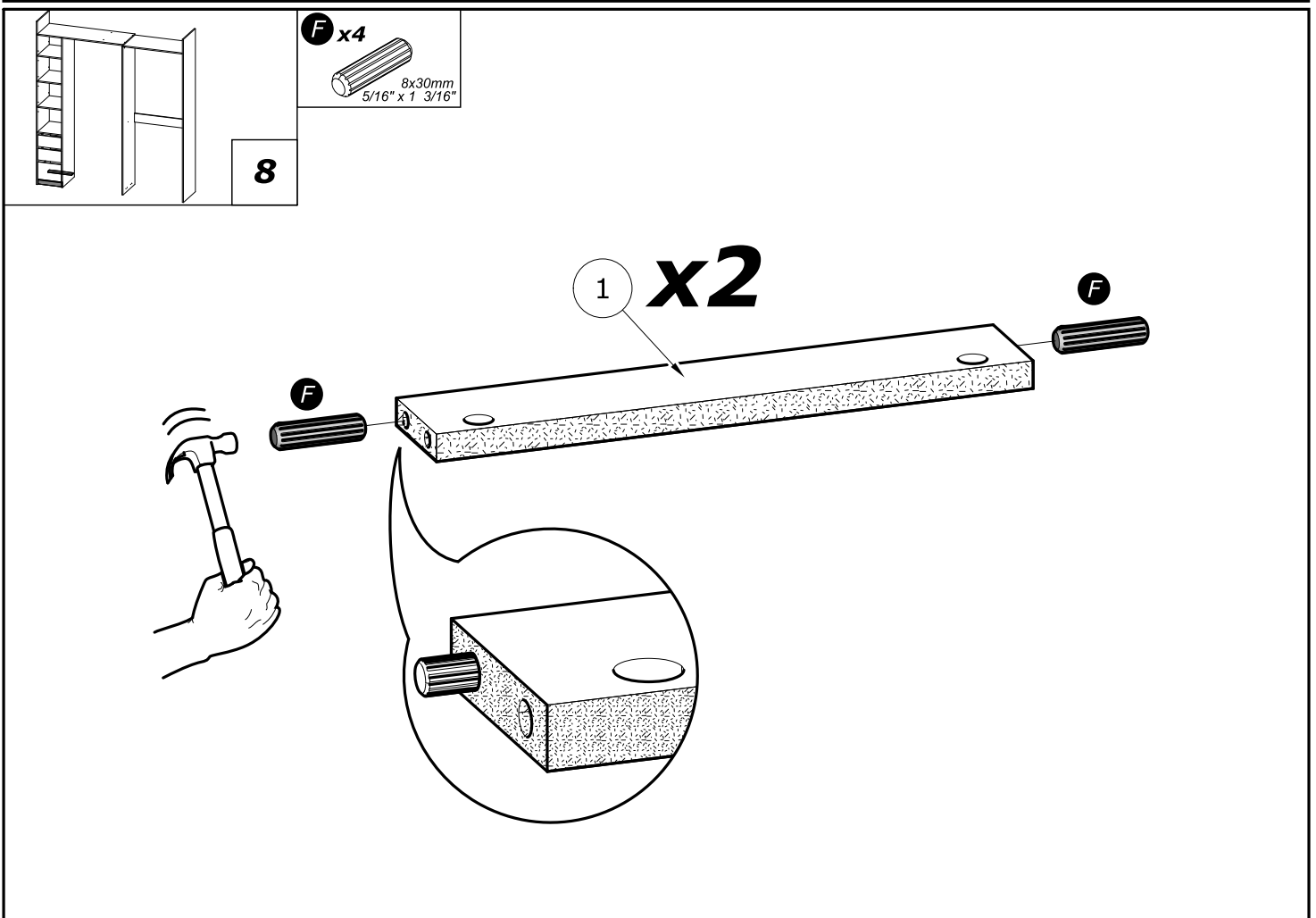
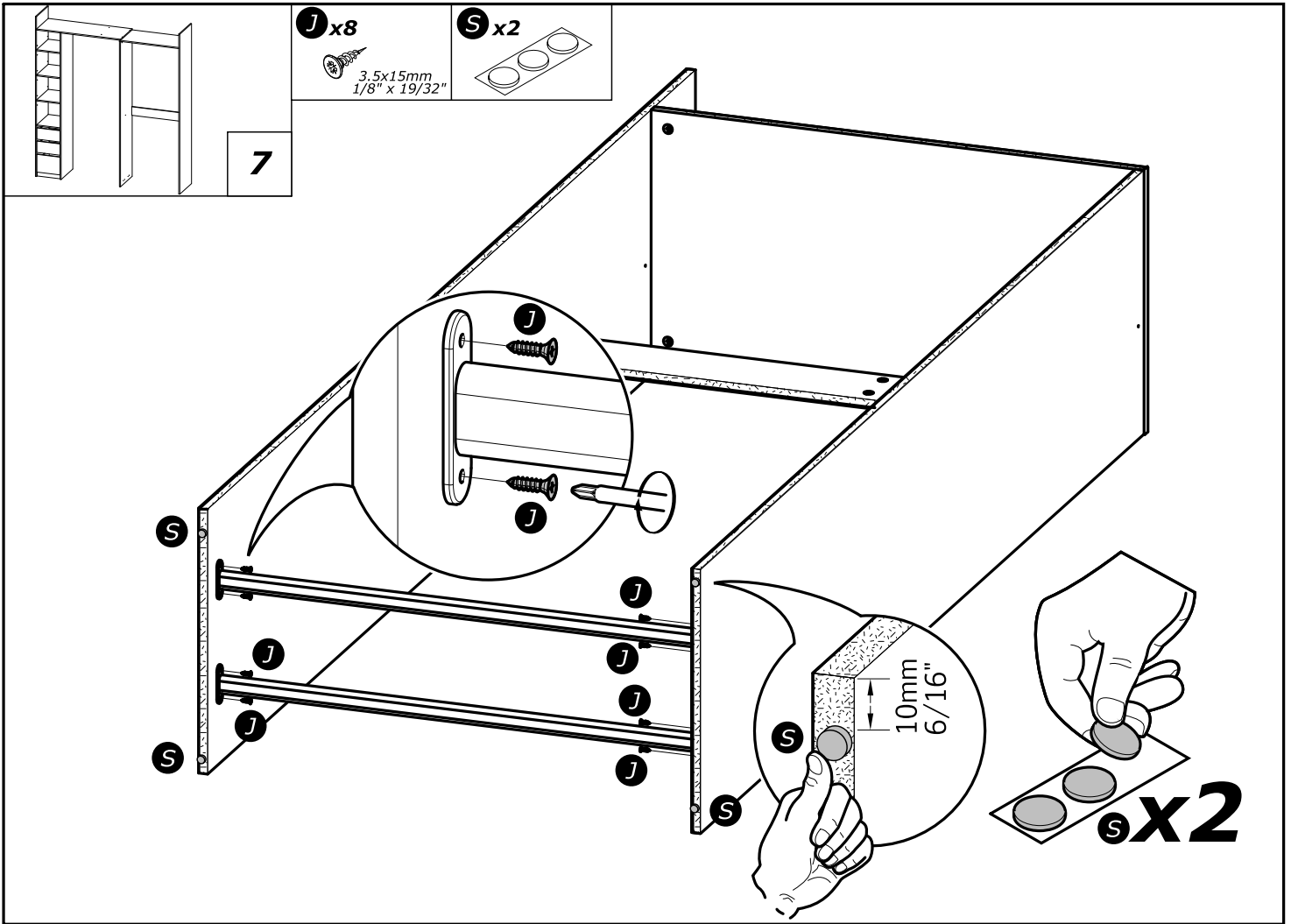

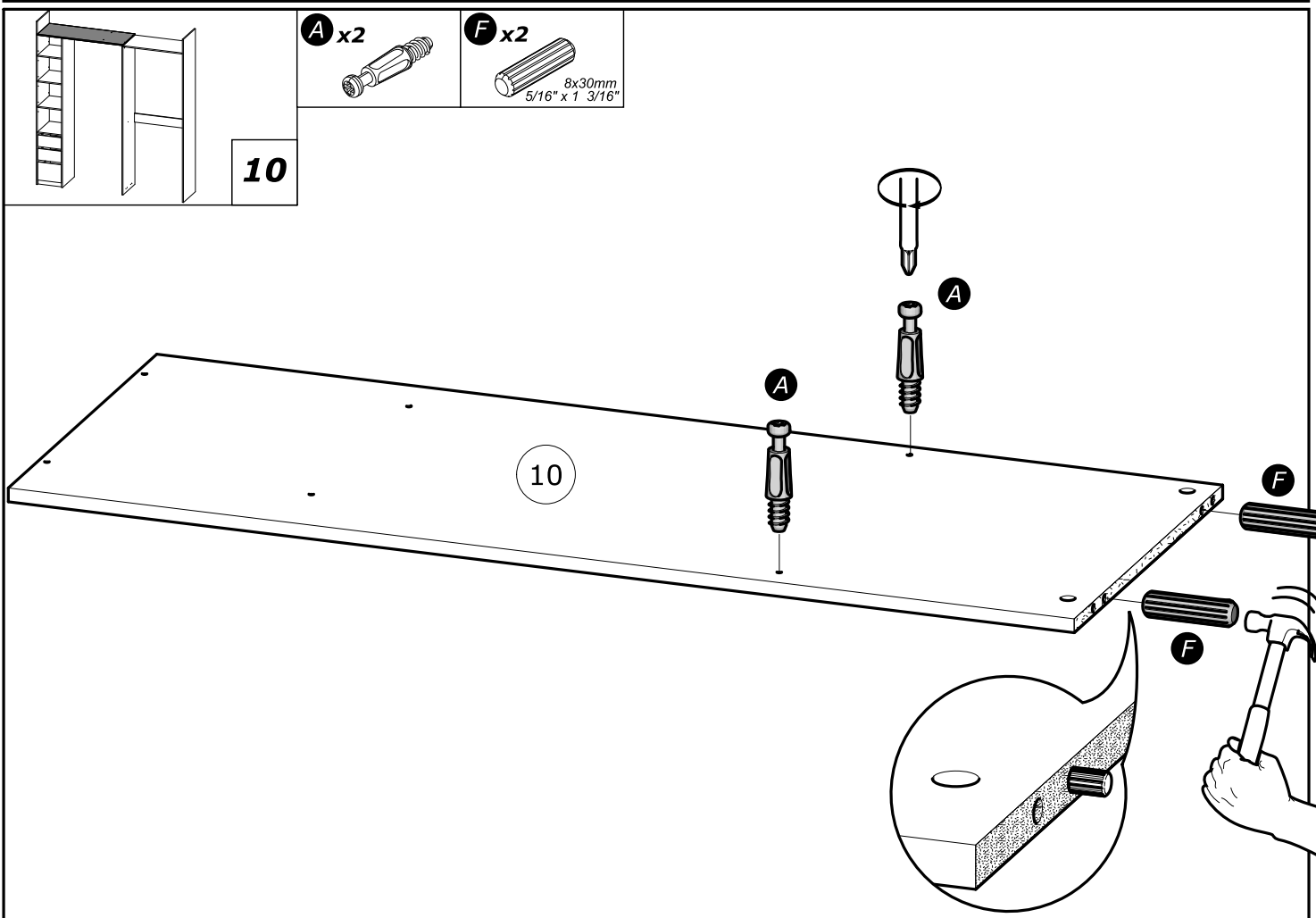
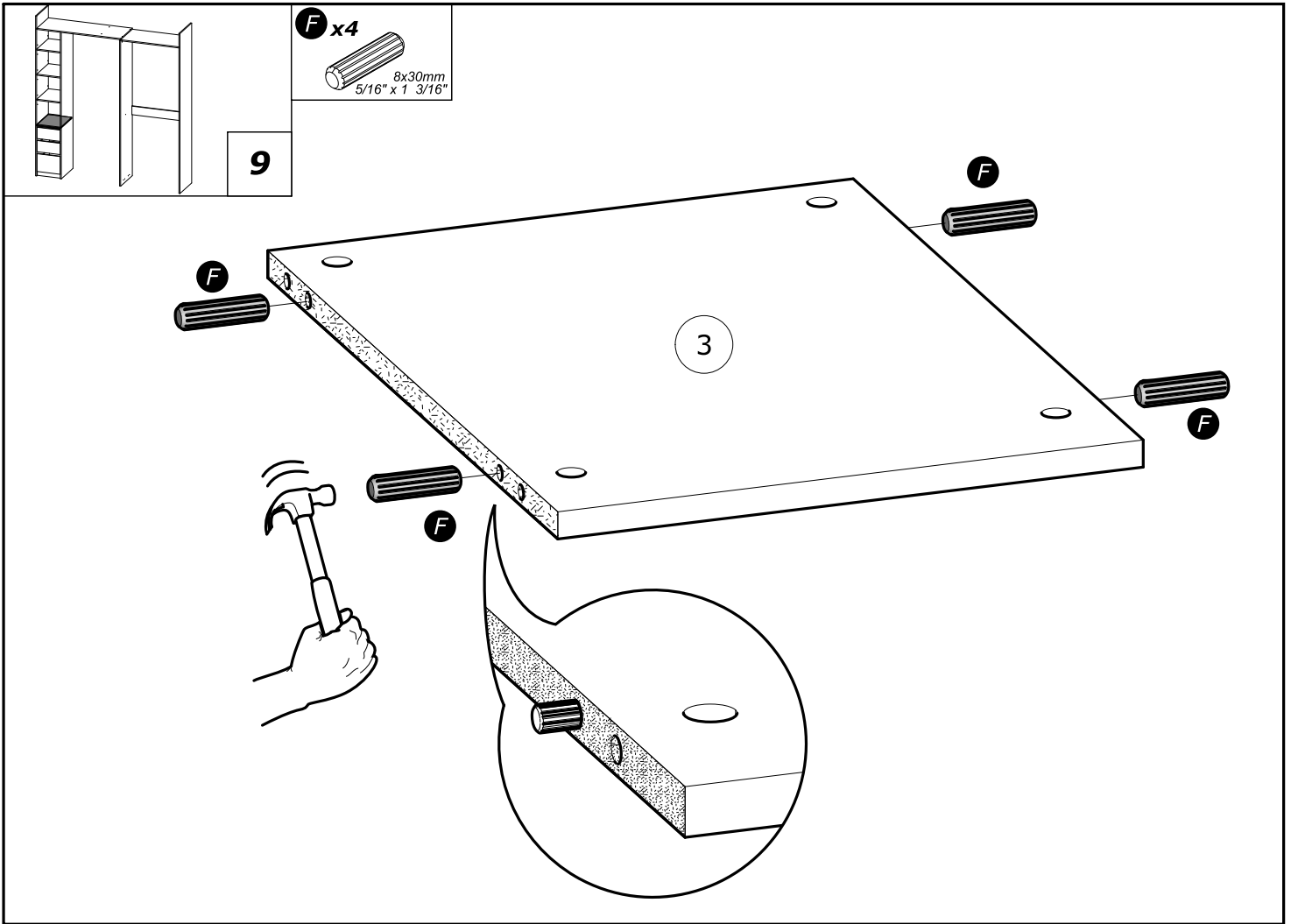

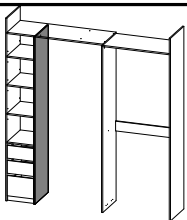

11

C x3

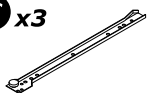

H x9

6.3x9mm
1/4" x 11/32"

I x3

3x12mm
1/8" x 15/32"



www.Demeyere.fr

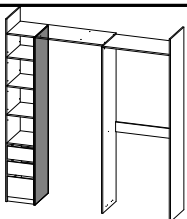
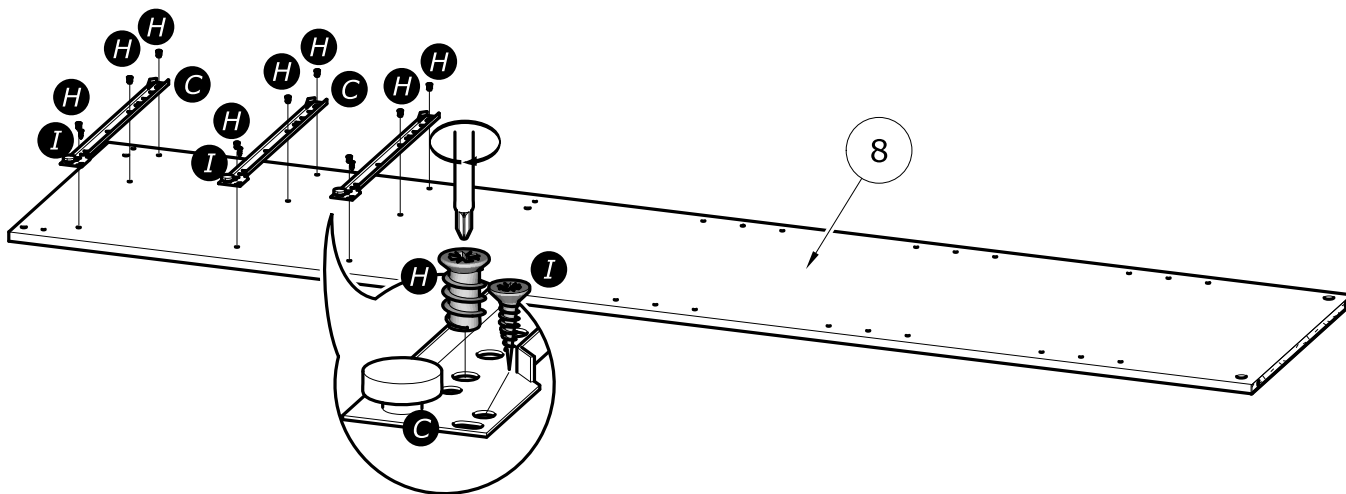

12

A x4

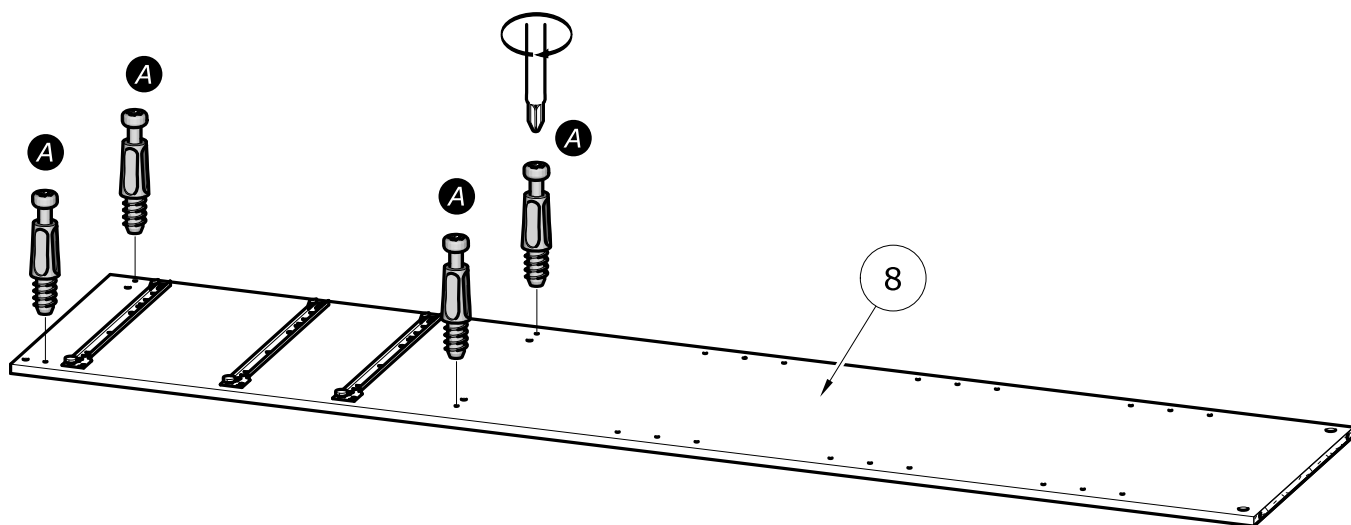
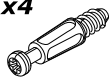

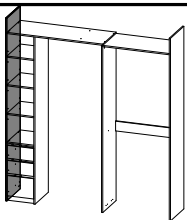

13

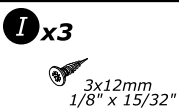
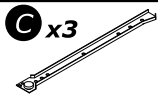

www.Demeyere.fr

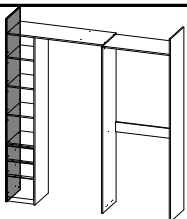
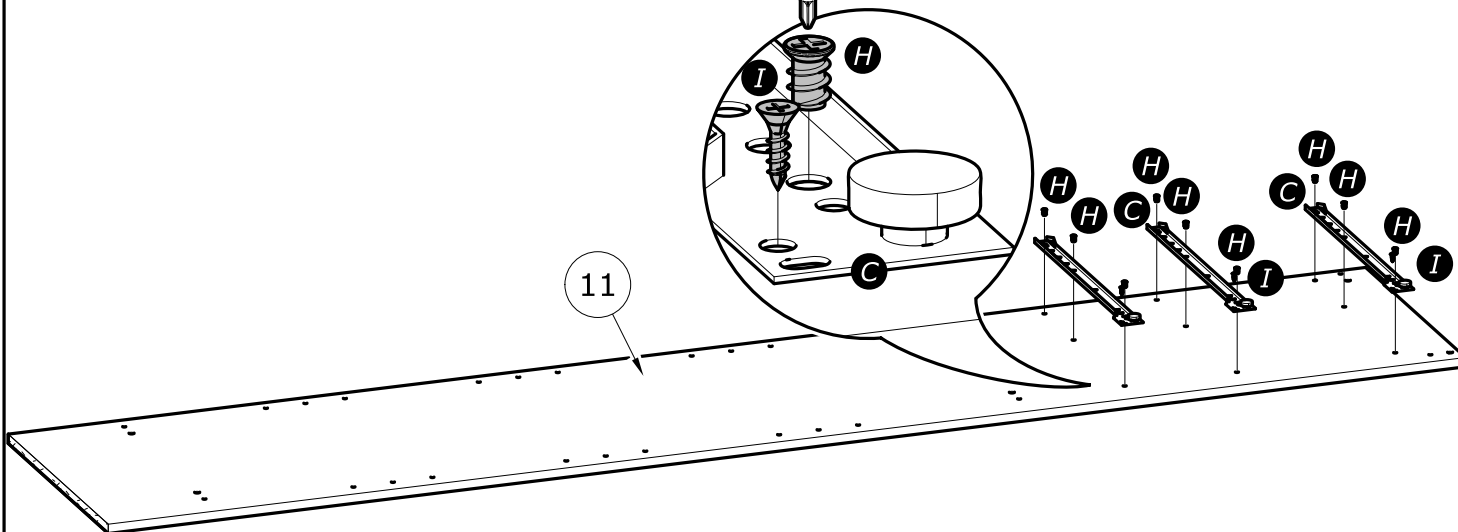

14

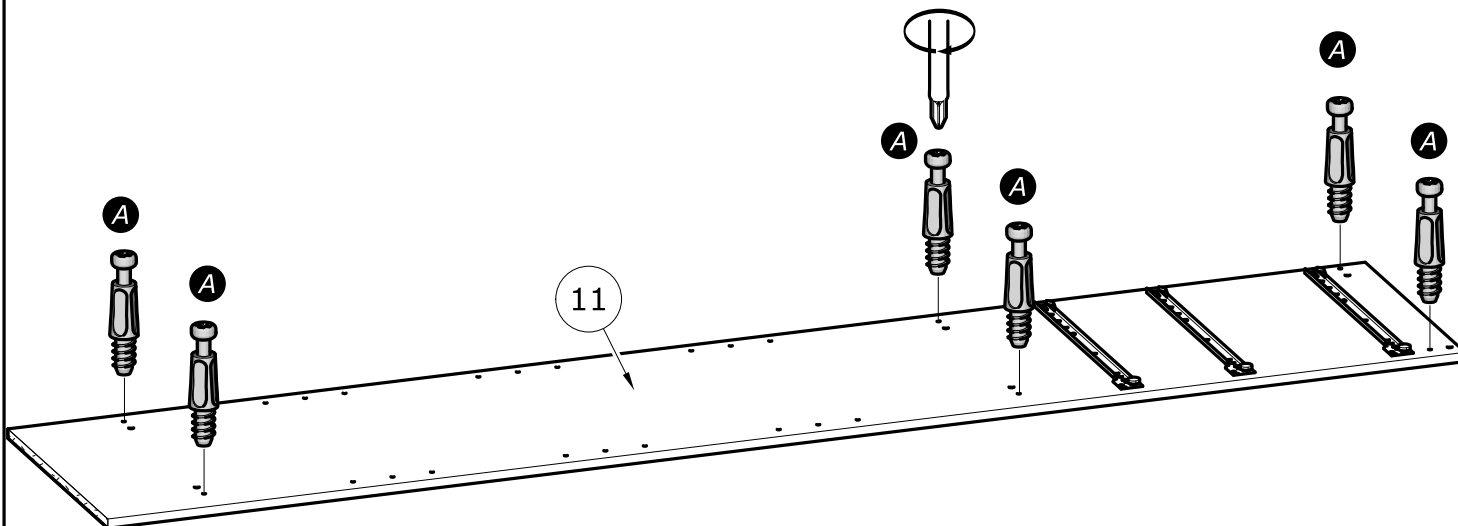
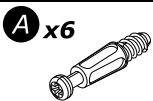

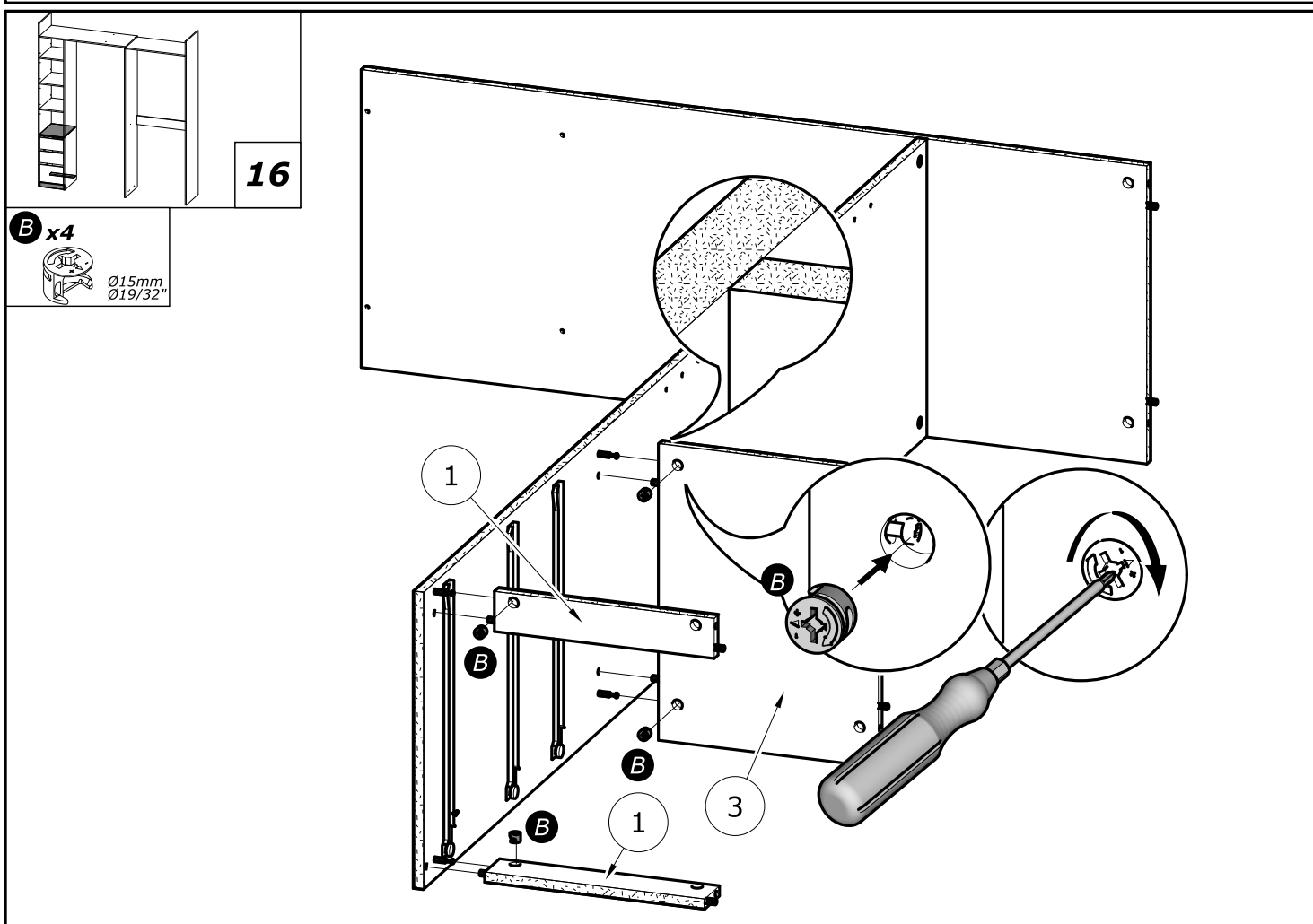
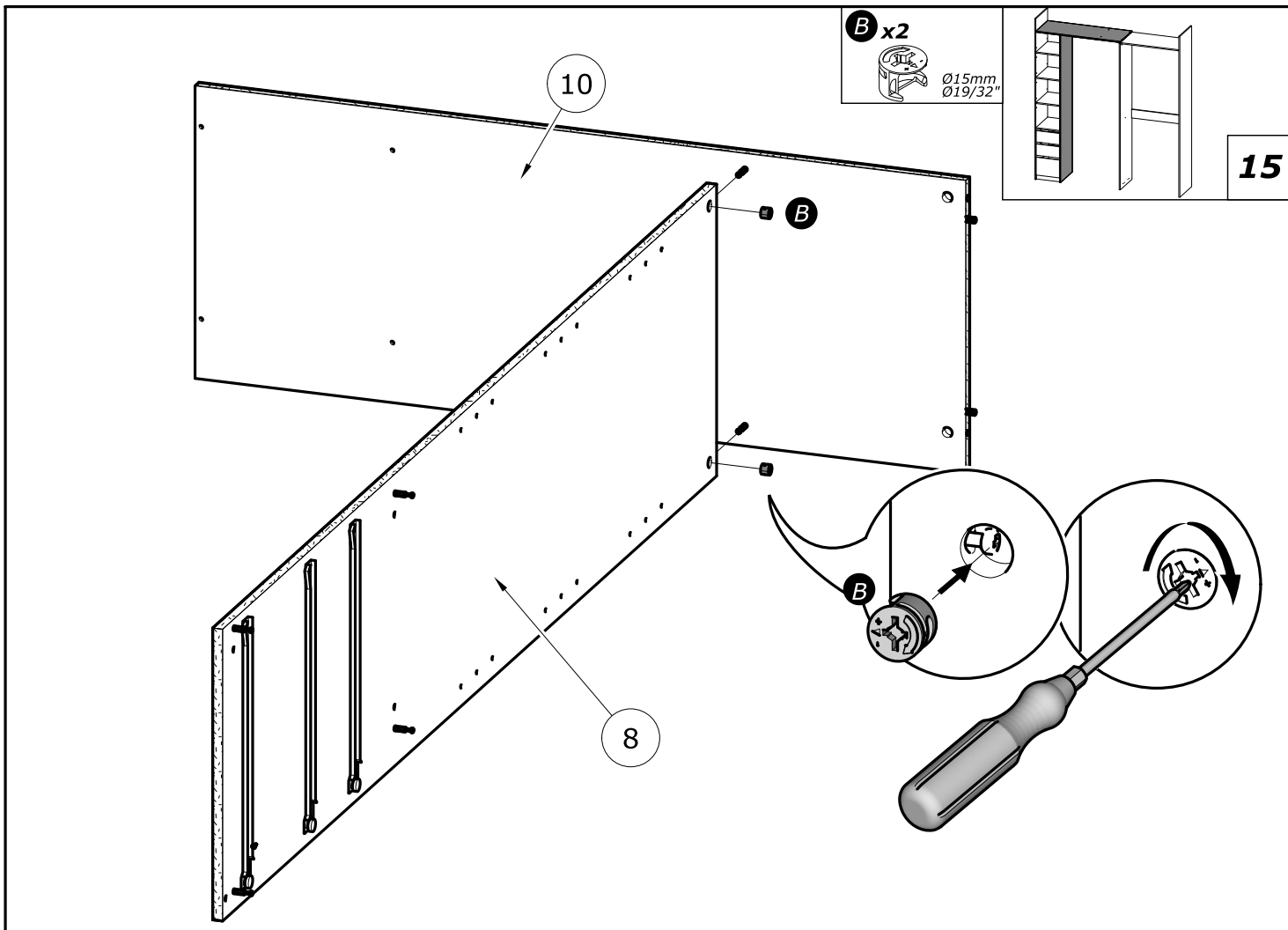

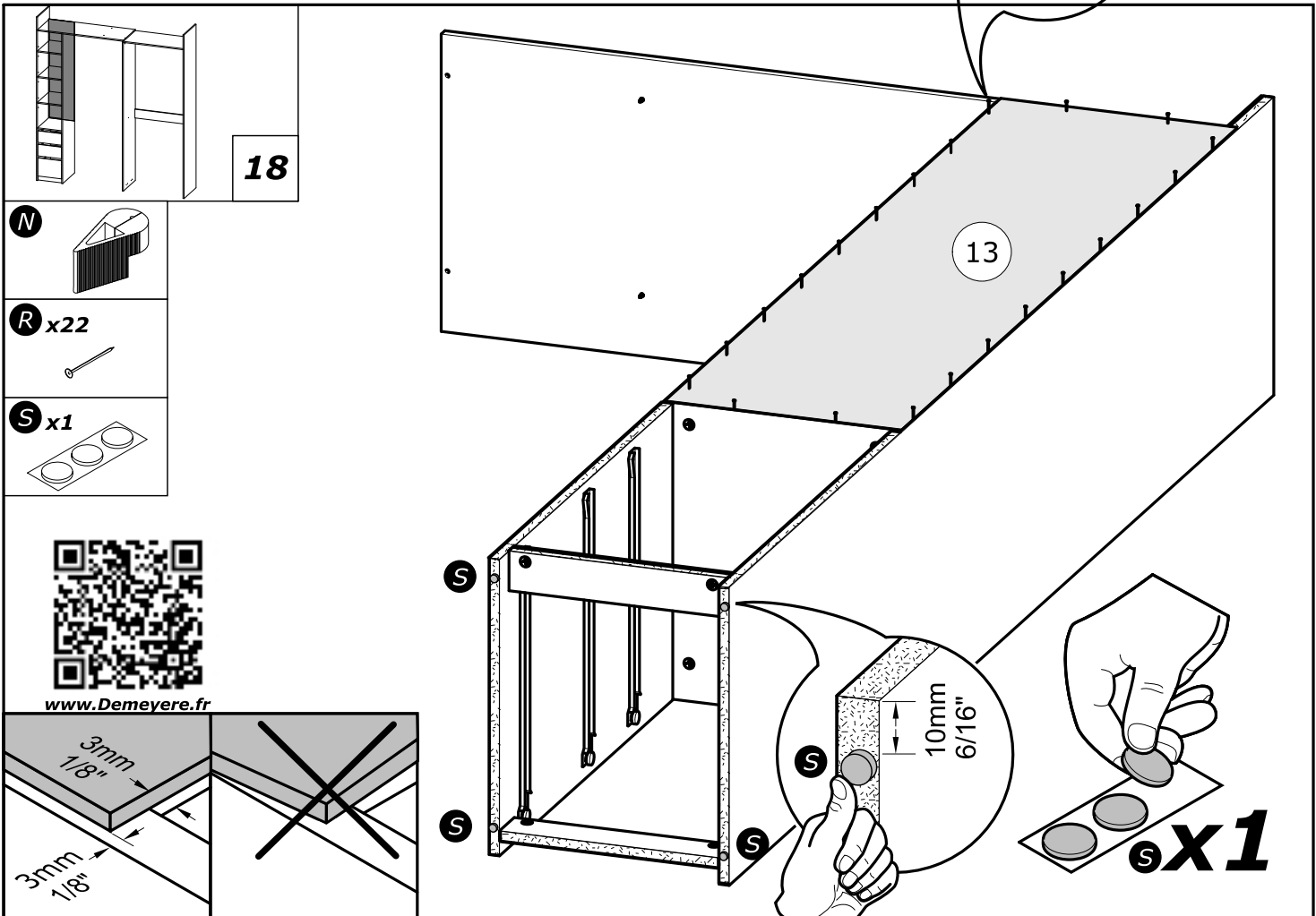
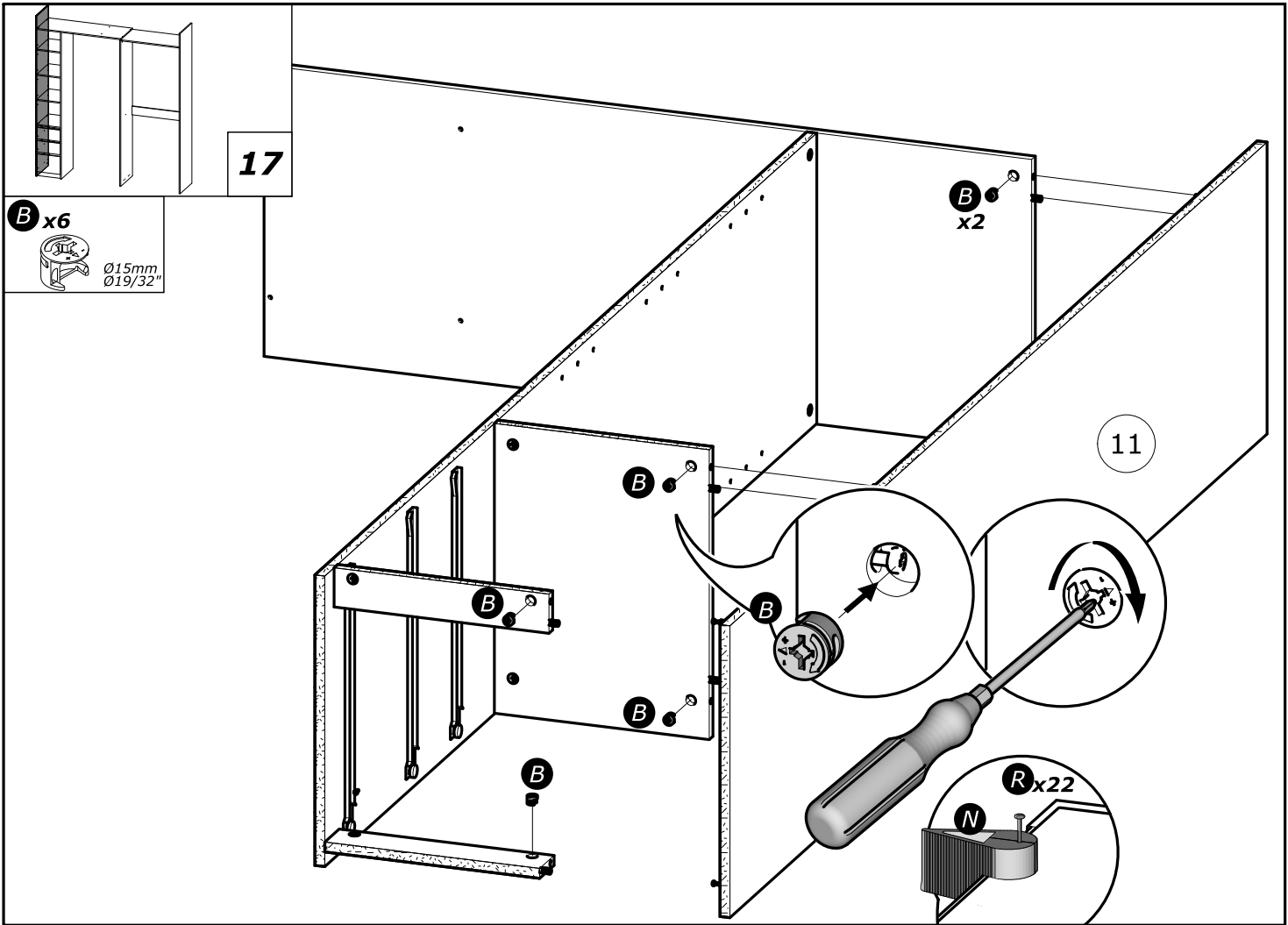

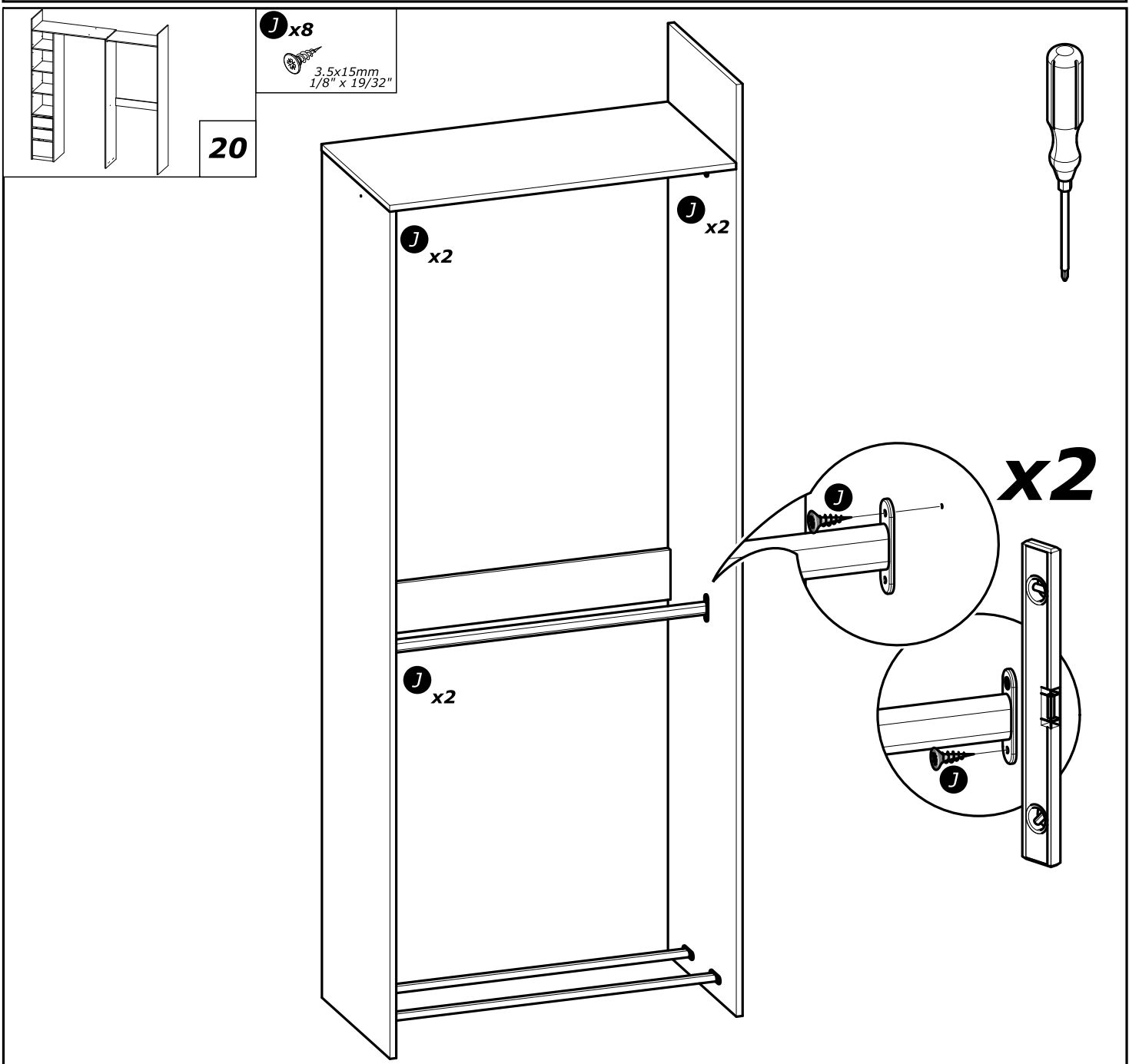
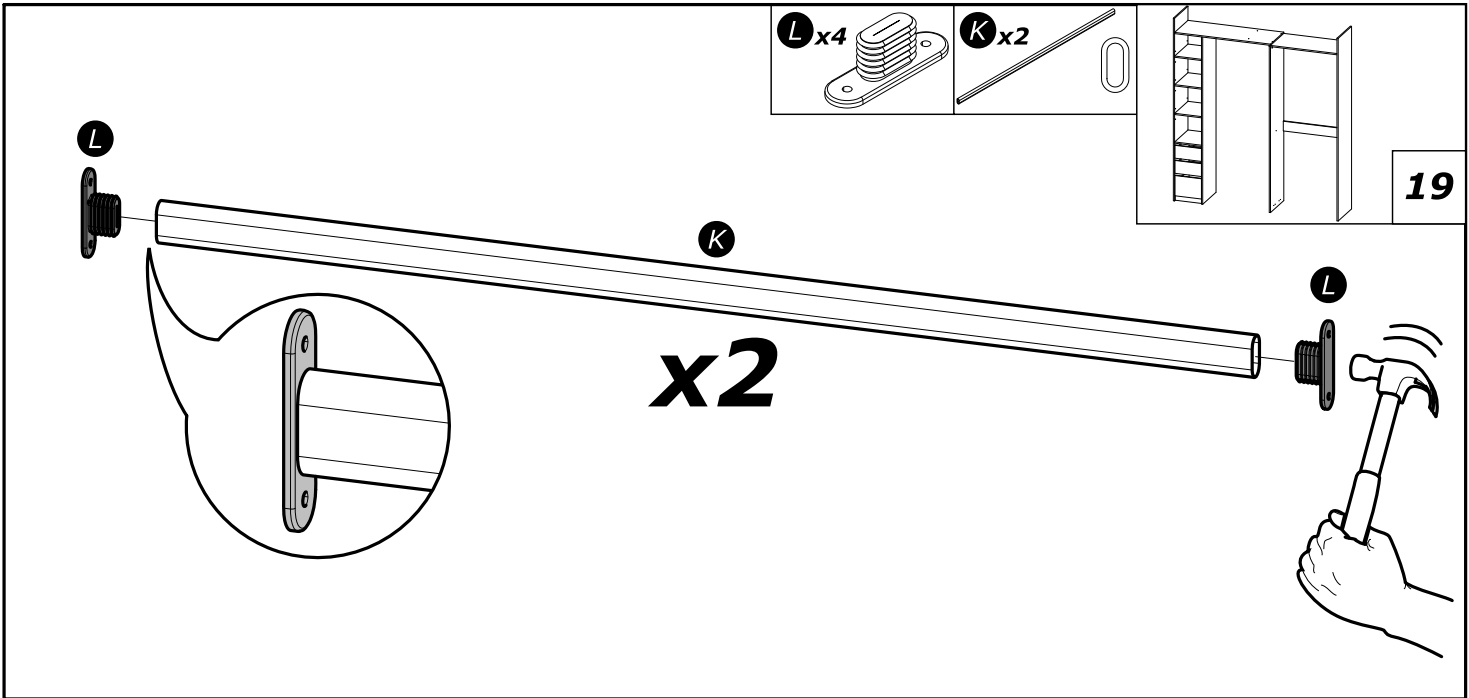

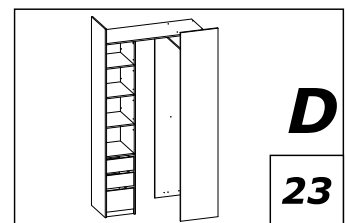
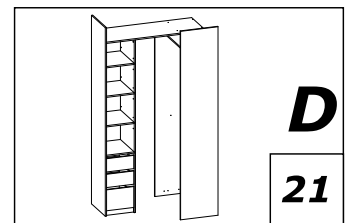
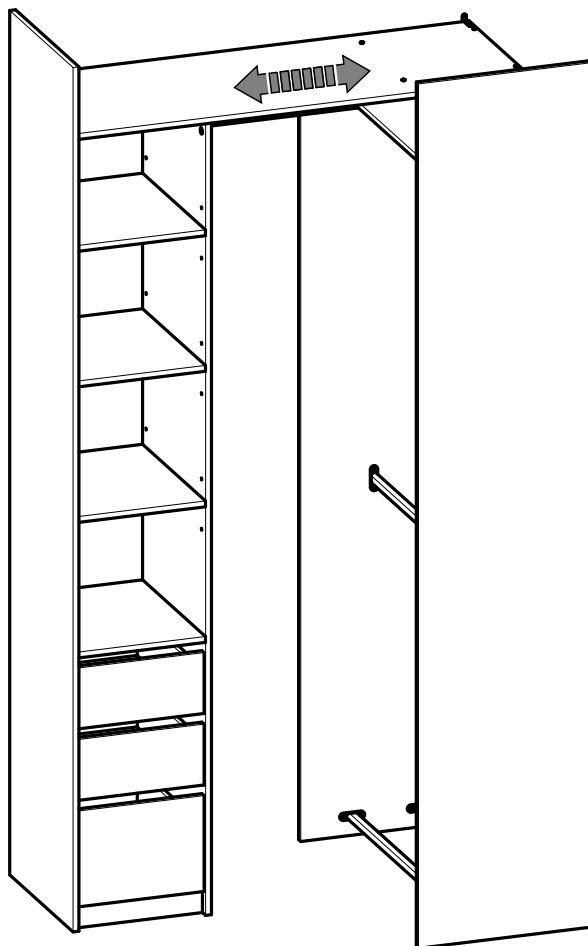
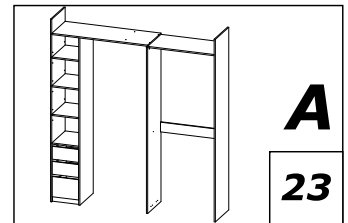
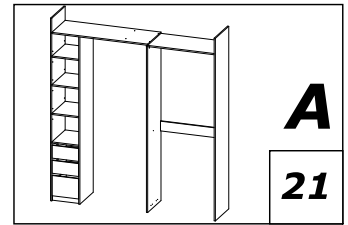
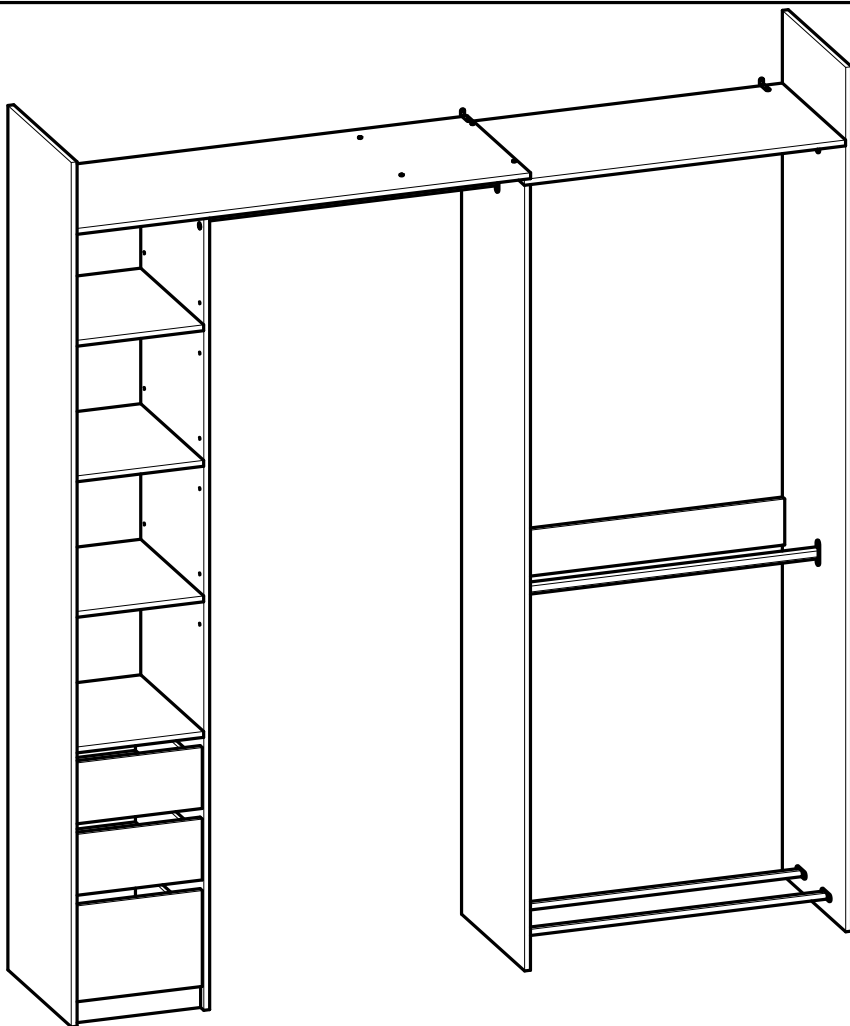

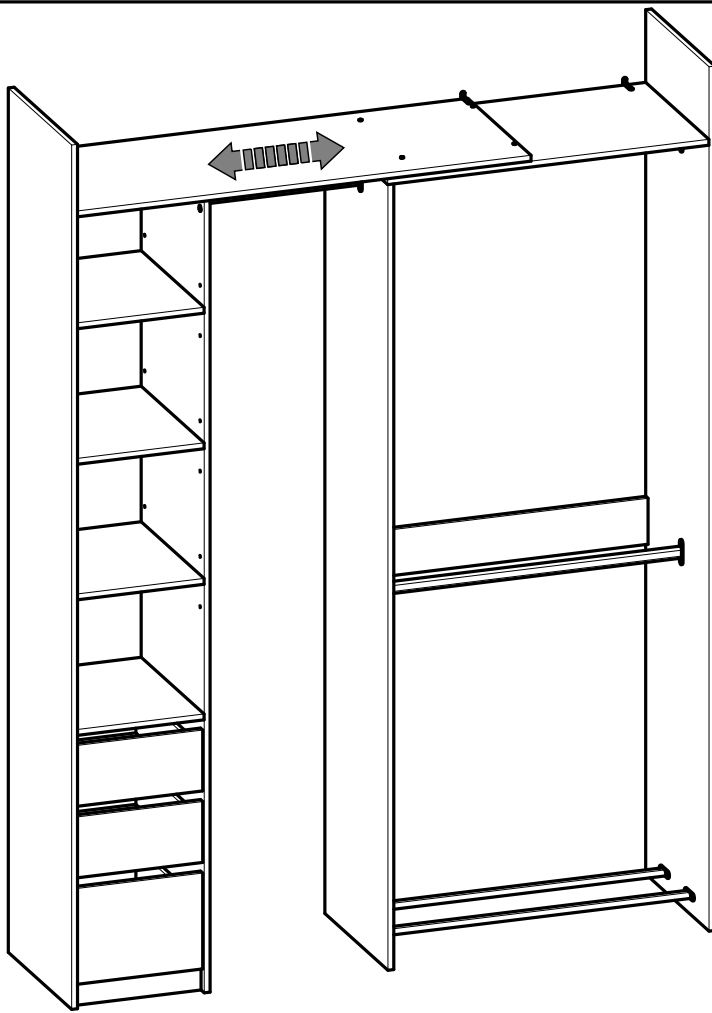

C

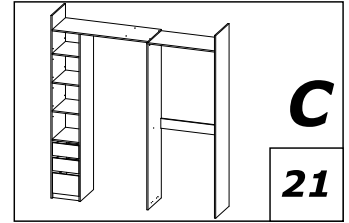

C
21

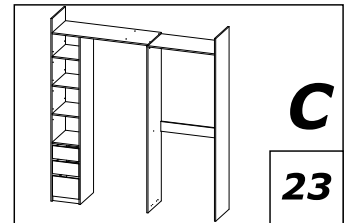

C
23

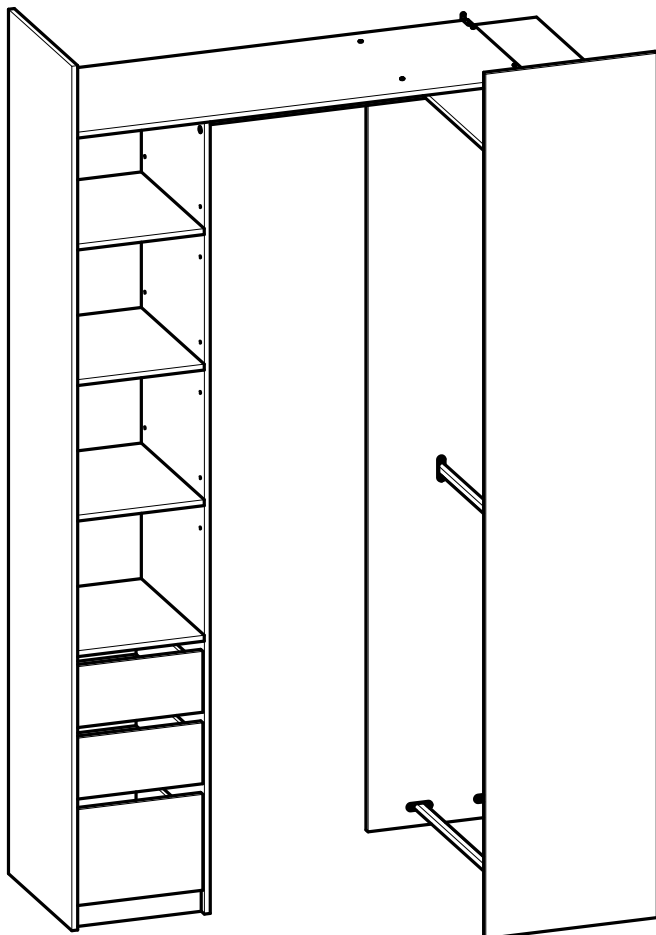

B

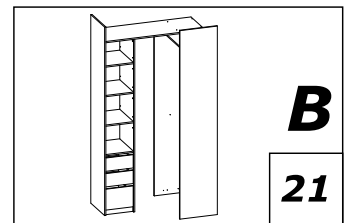

B
21

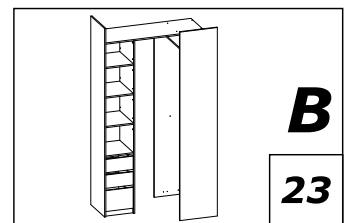

B
23

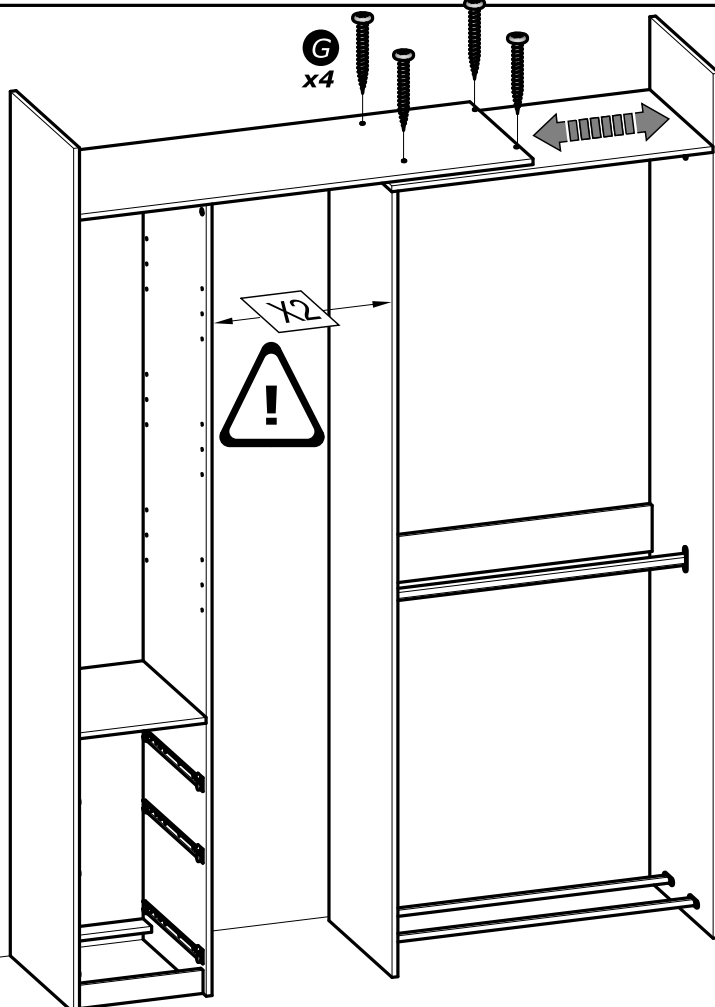
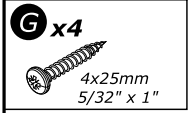
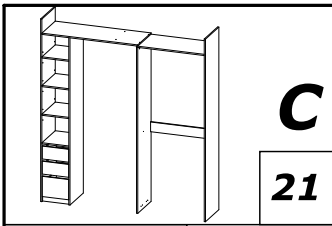
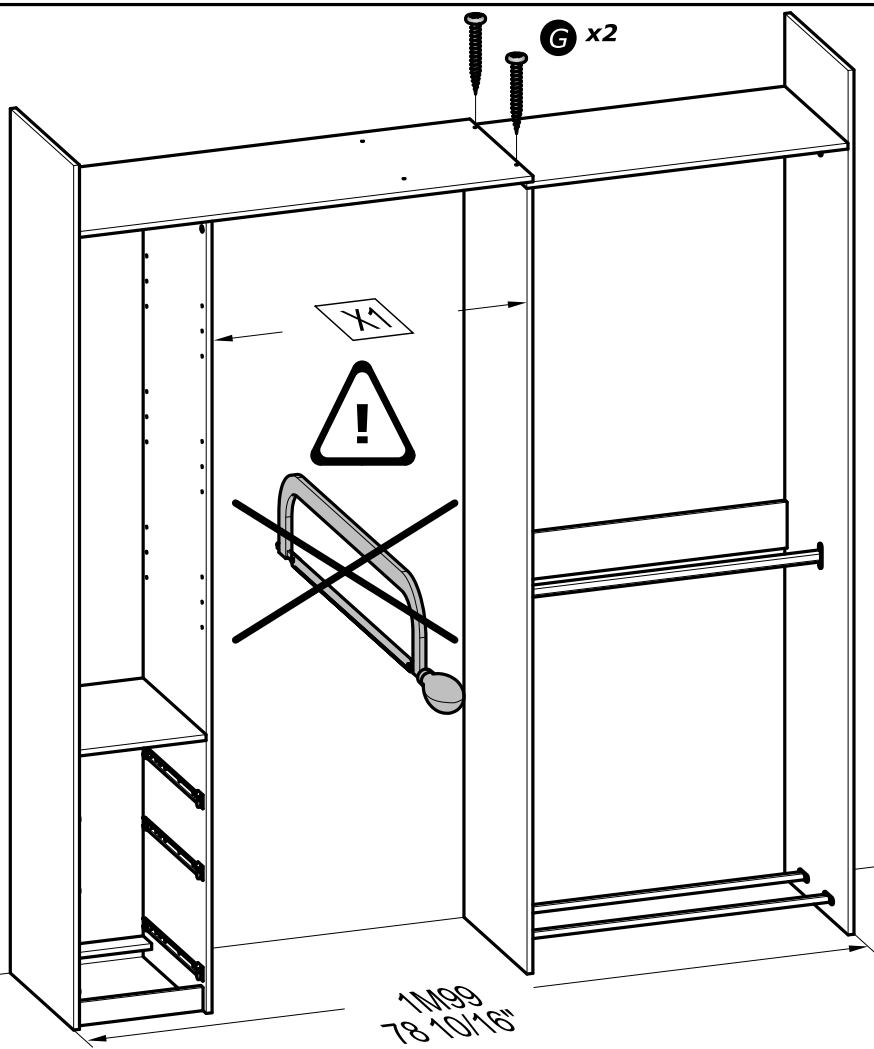
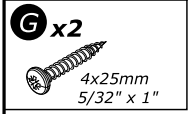
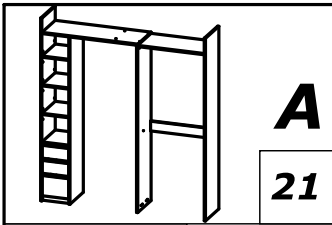

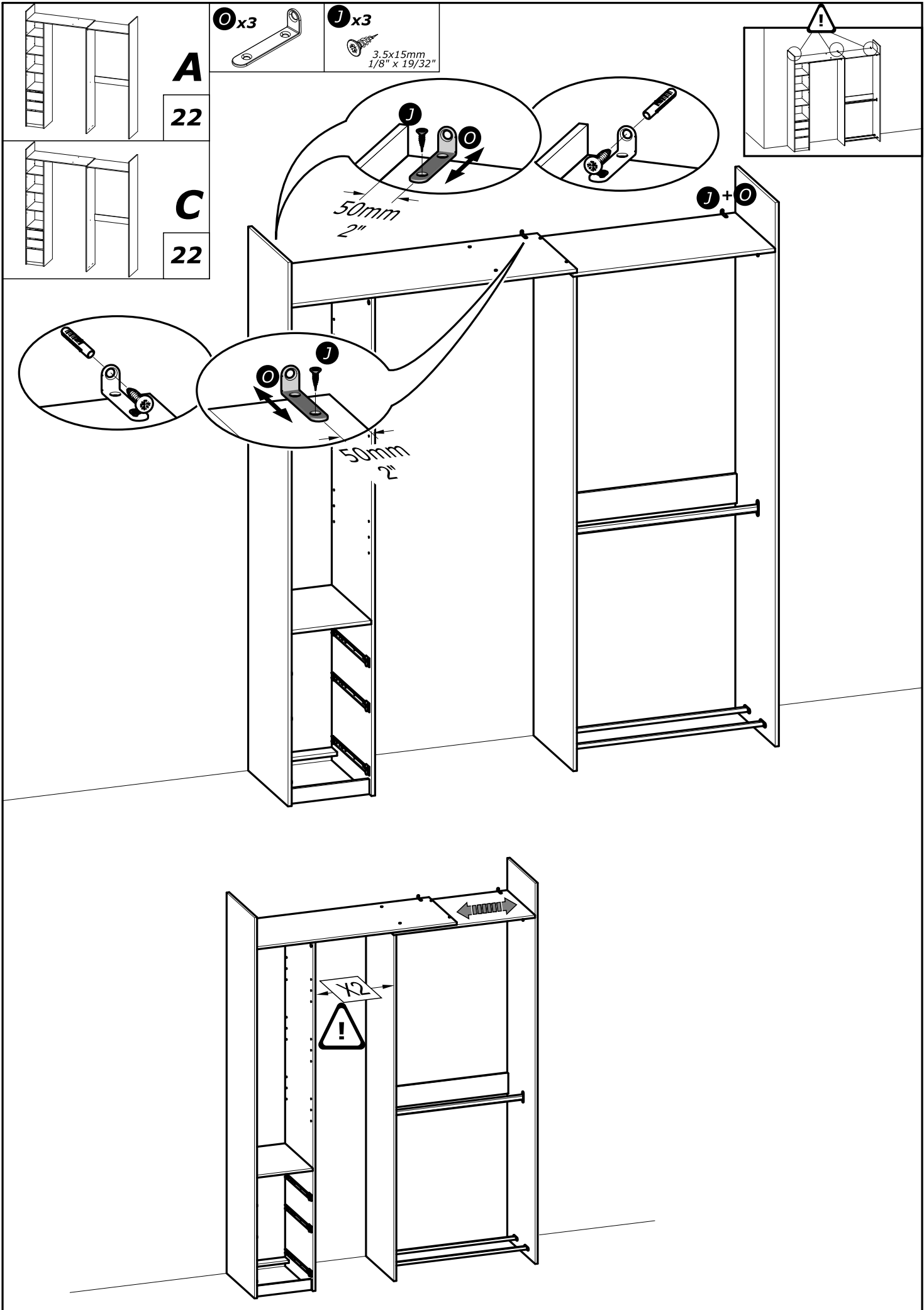

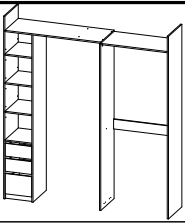

A

23

L x2	K x1	J x4
		3.5x15mm 1/8" x 19/32"

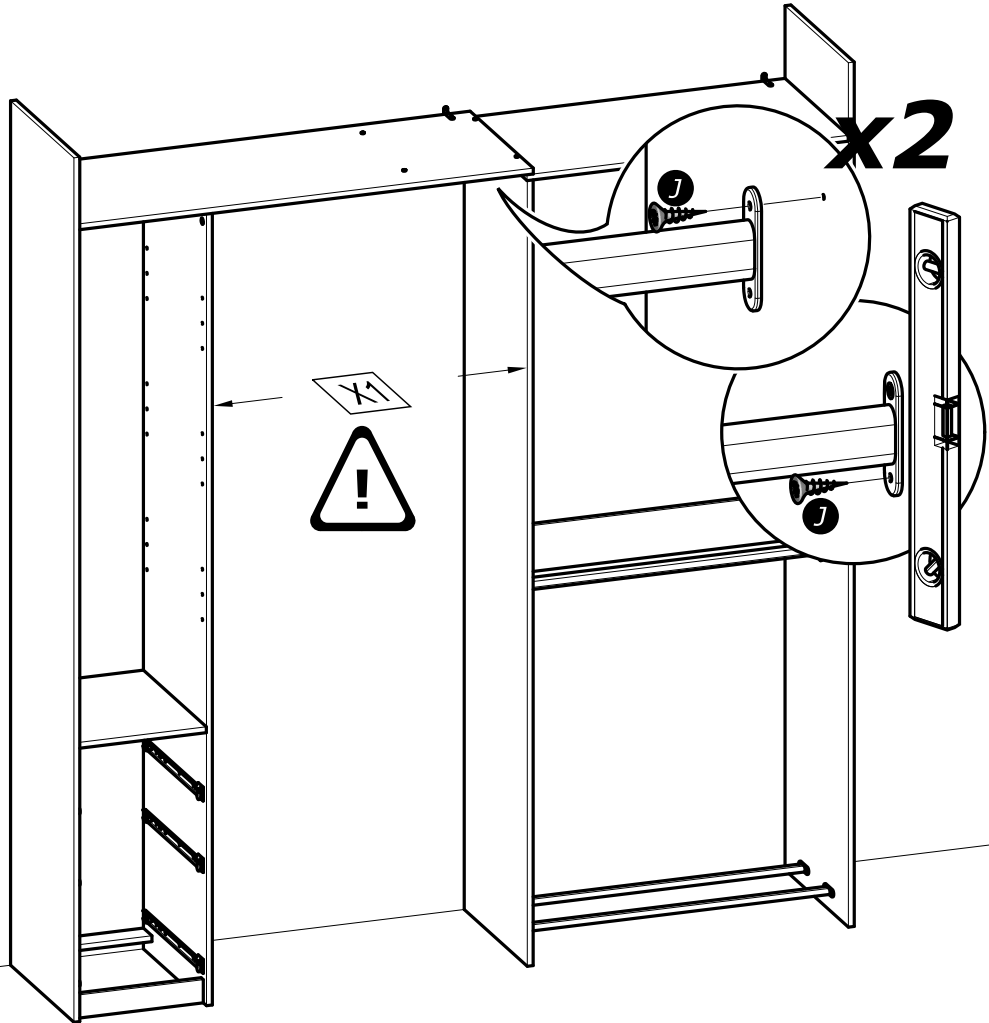
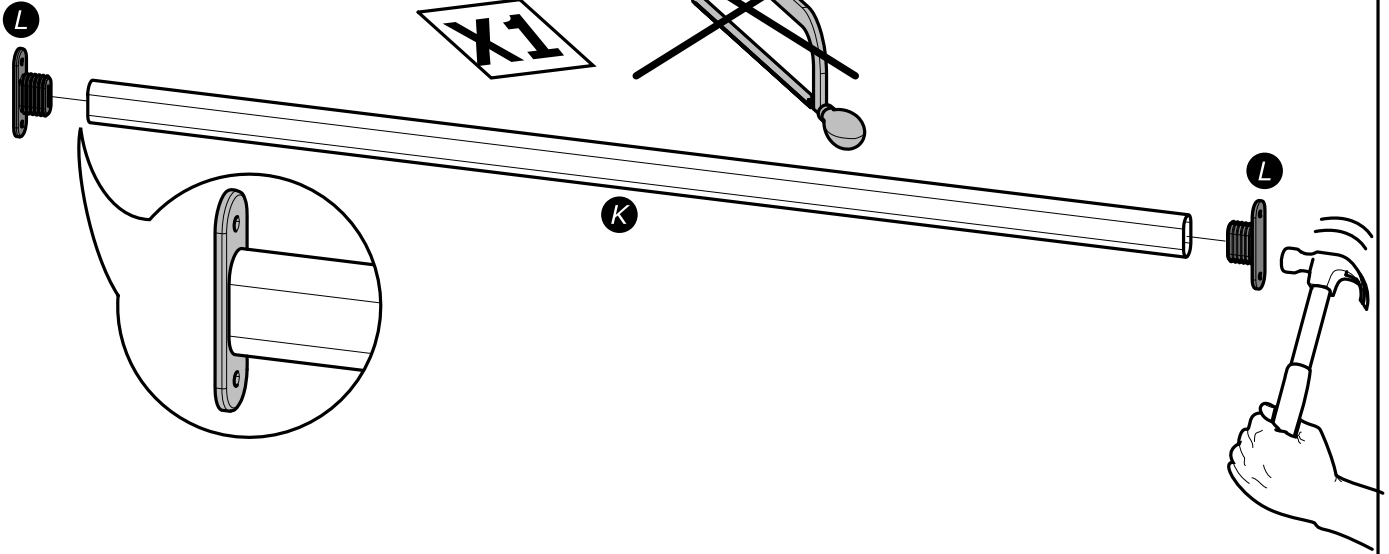

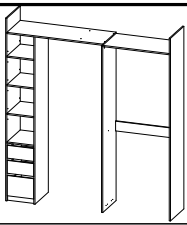

C
23

- L** x2
- K** x1
- J** x4
- 3.5x15mm
1/8" x 19/32"

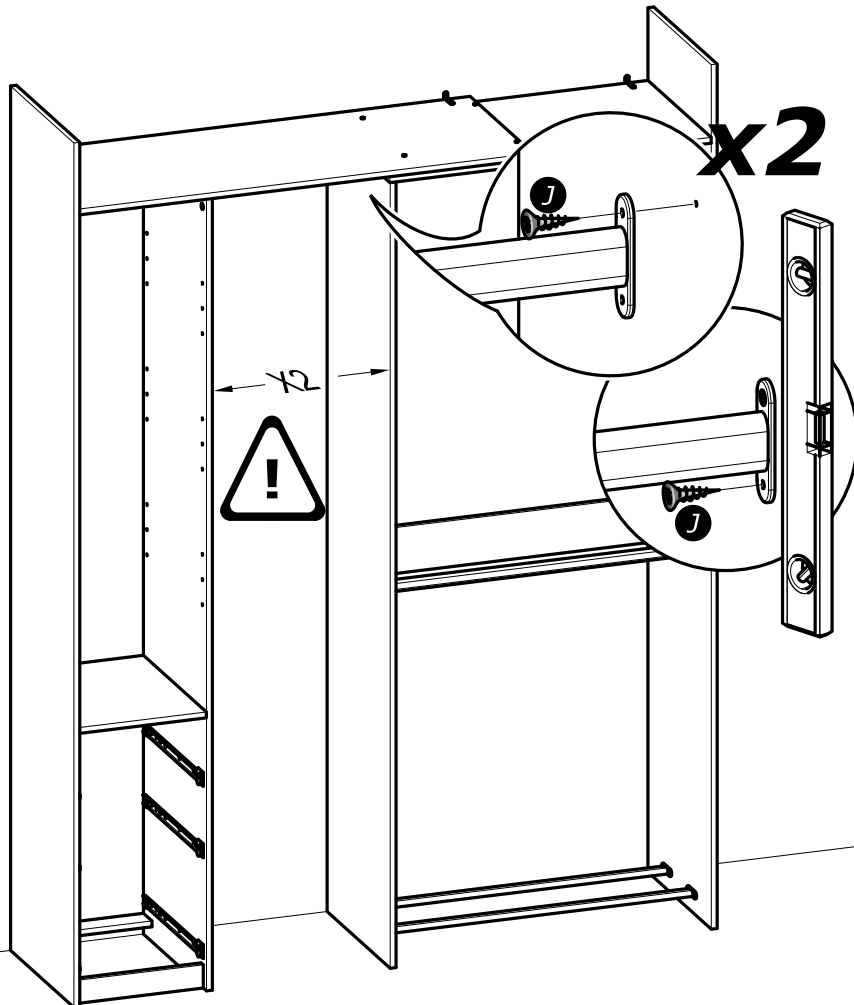
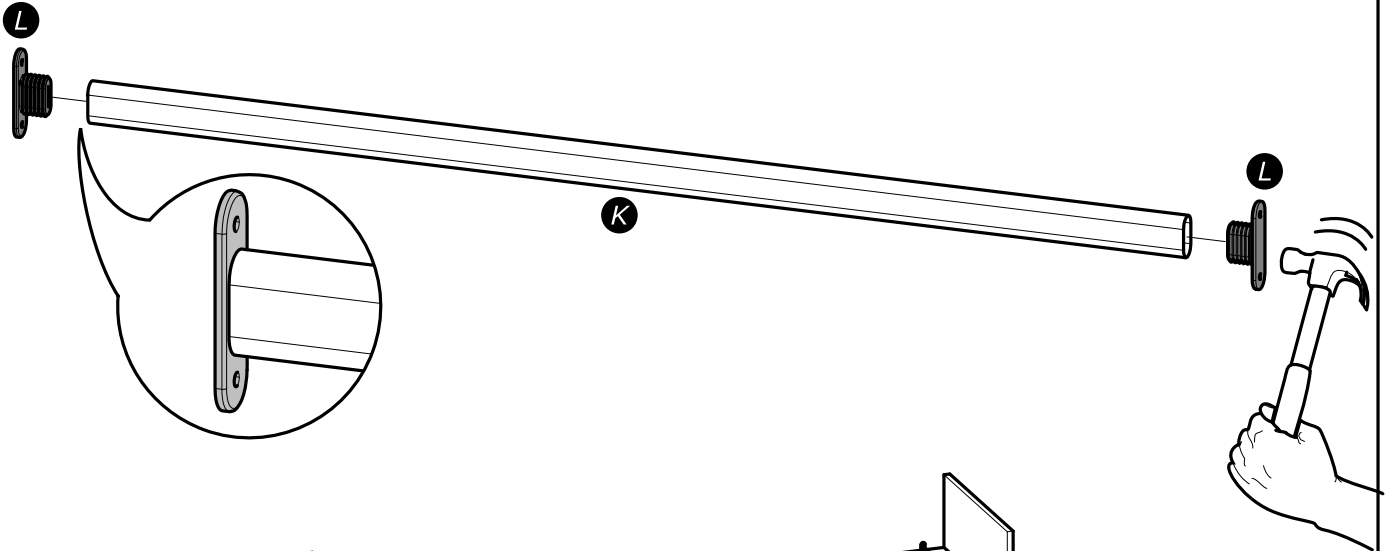
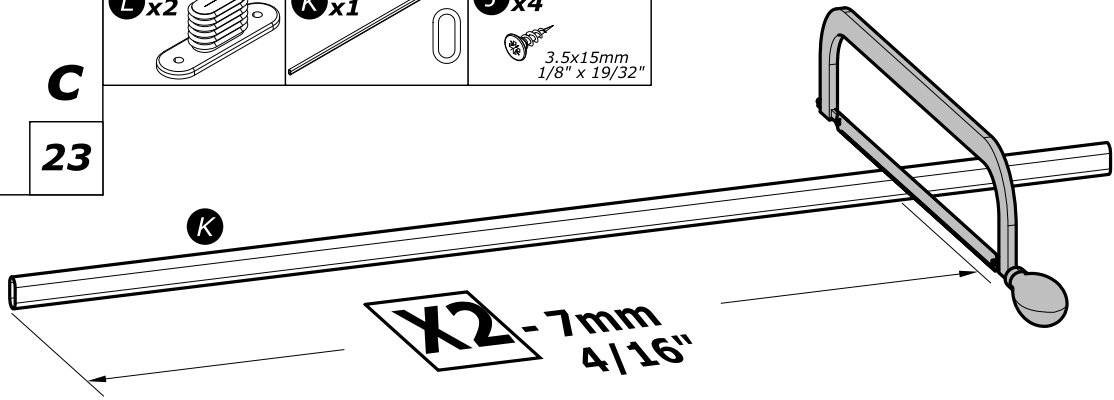

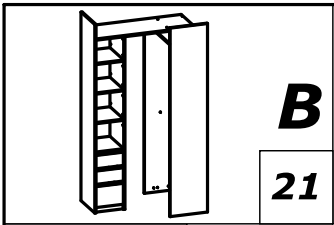

21

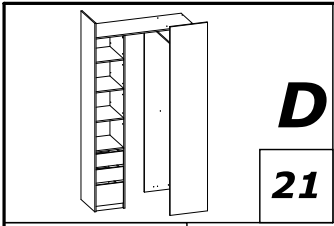
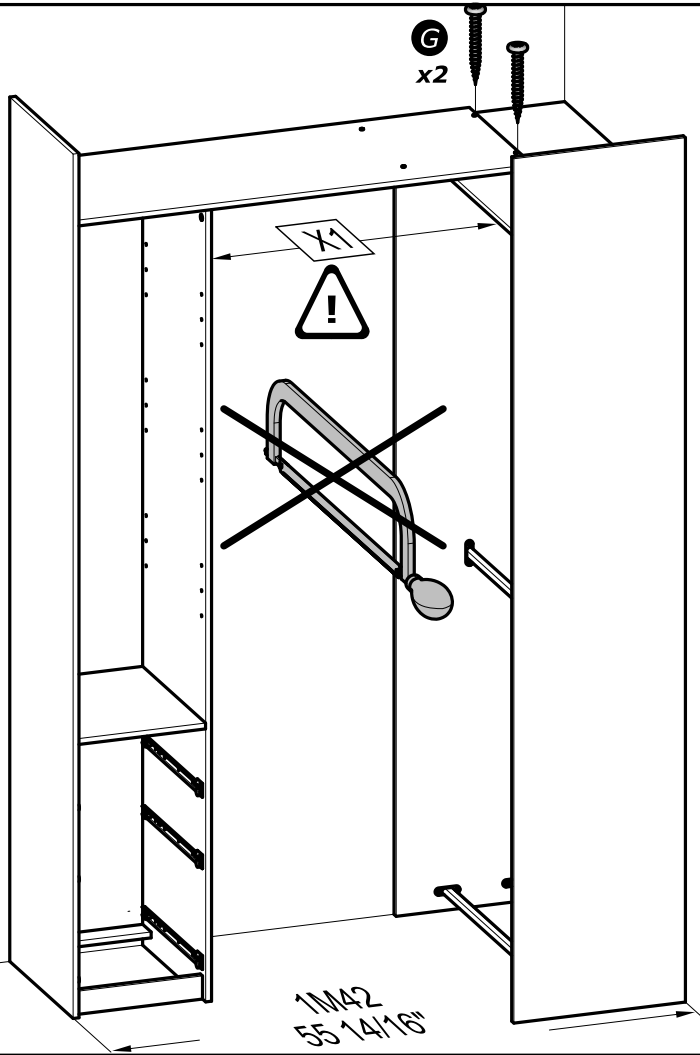
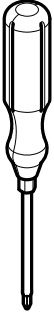
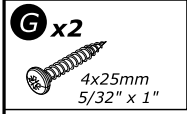

21

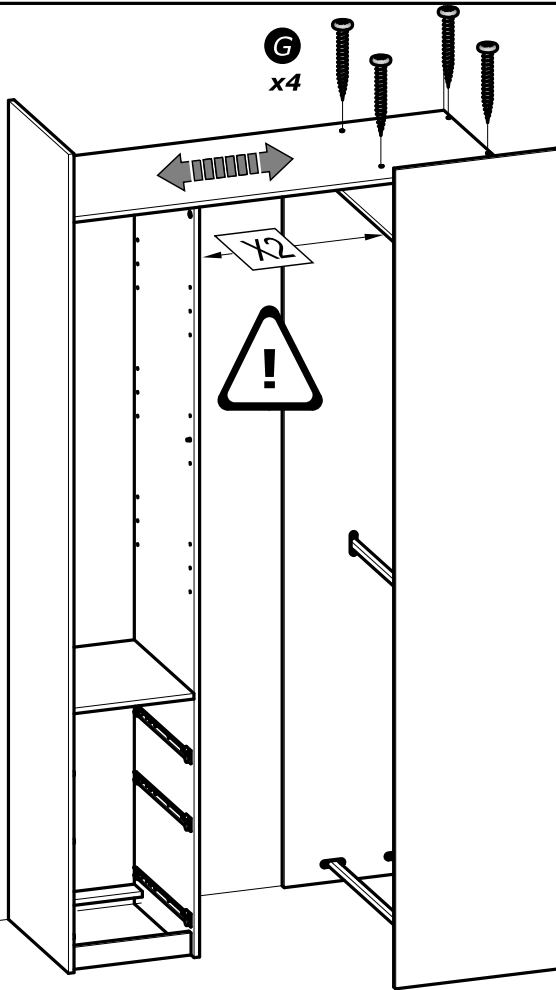
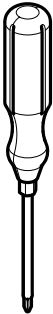
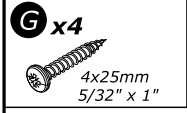

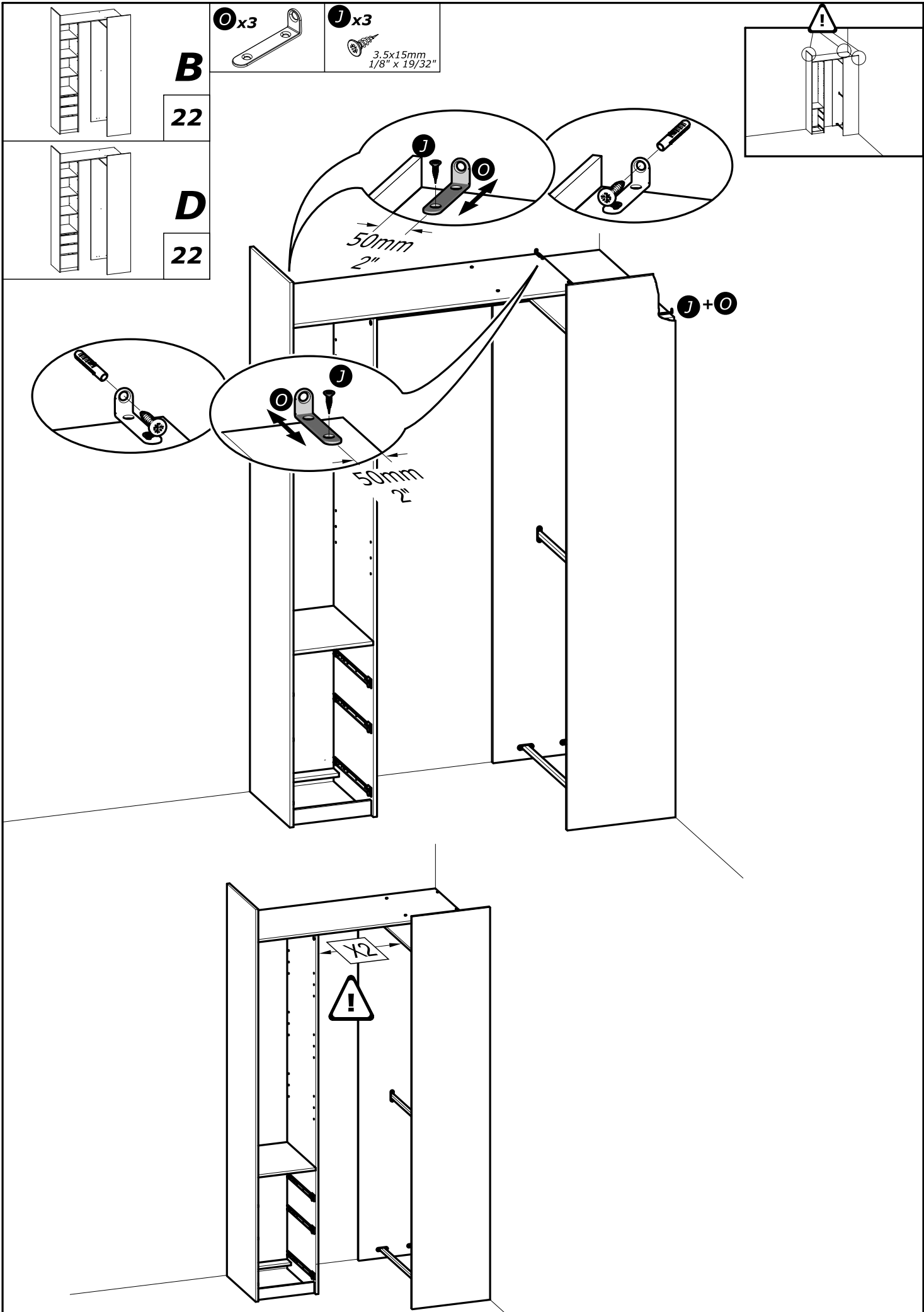

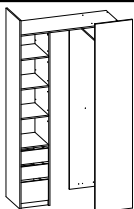

B
23

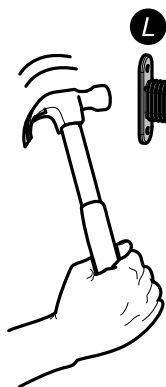
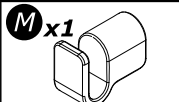

L

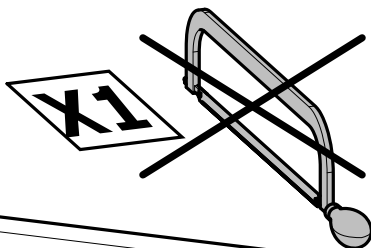
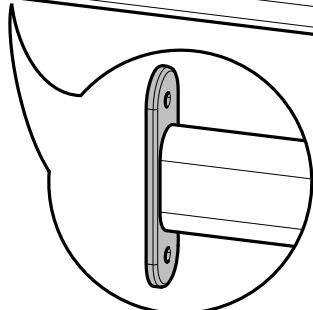

K

M

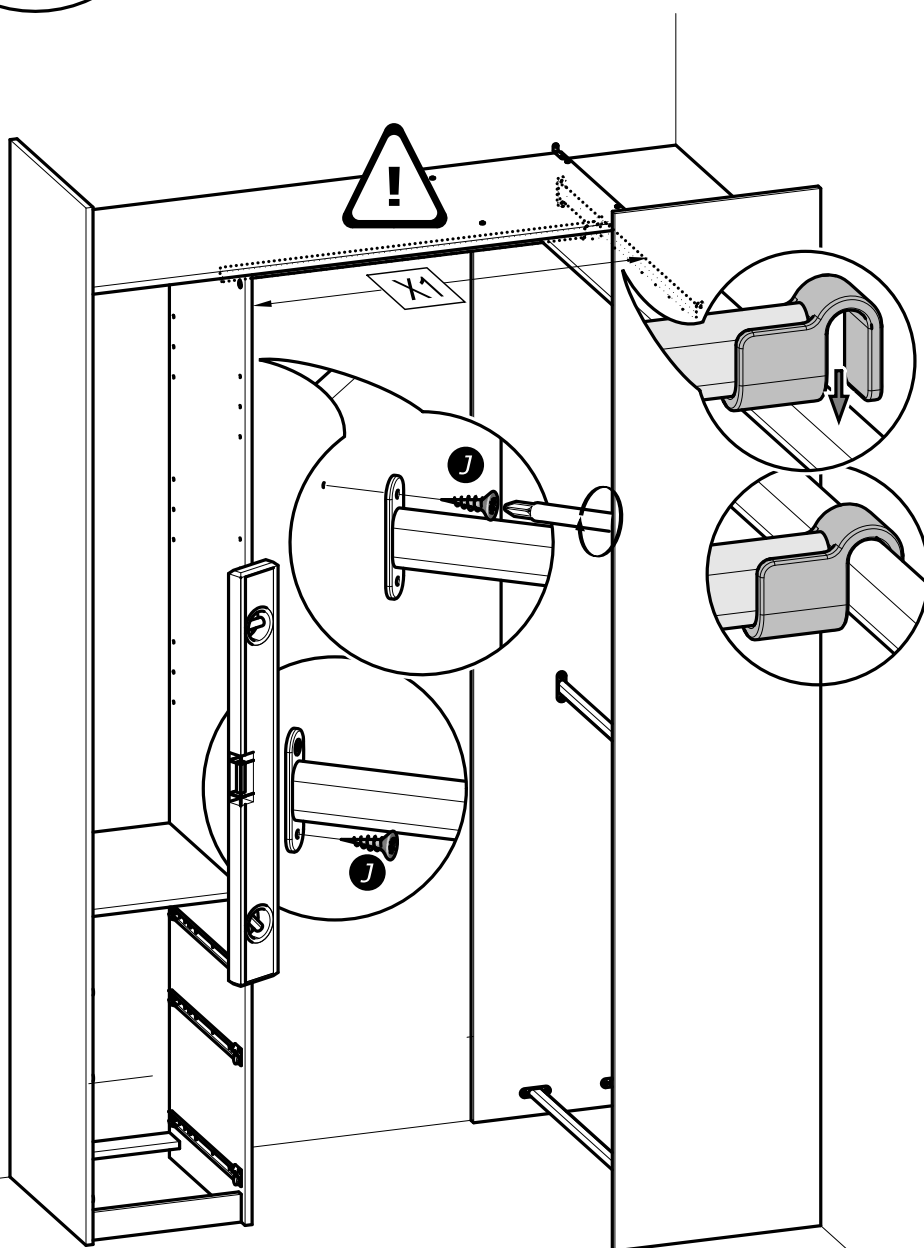

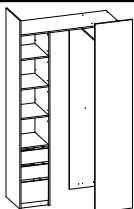

D
23

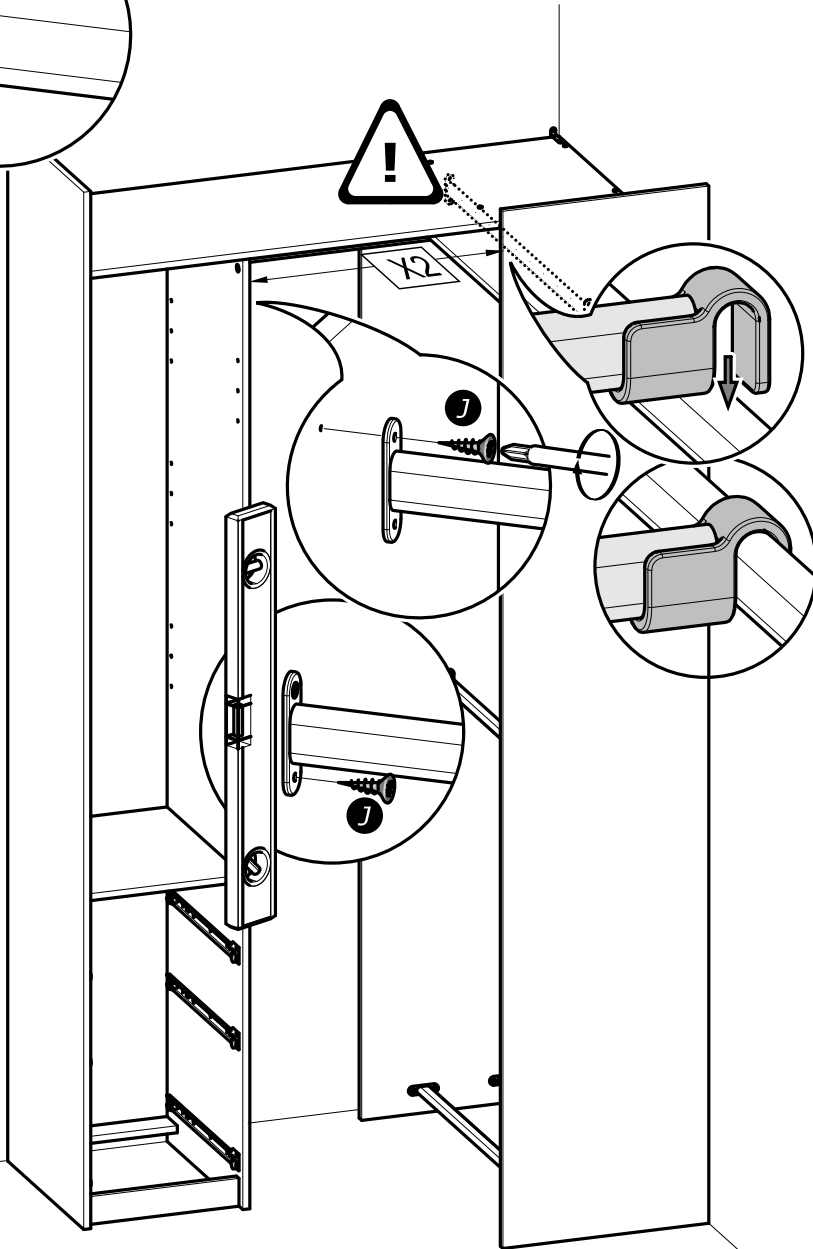
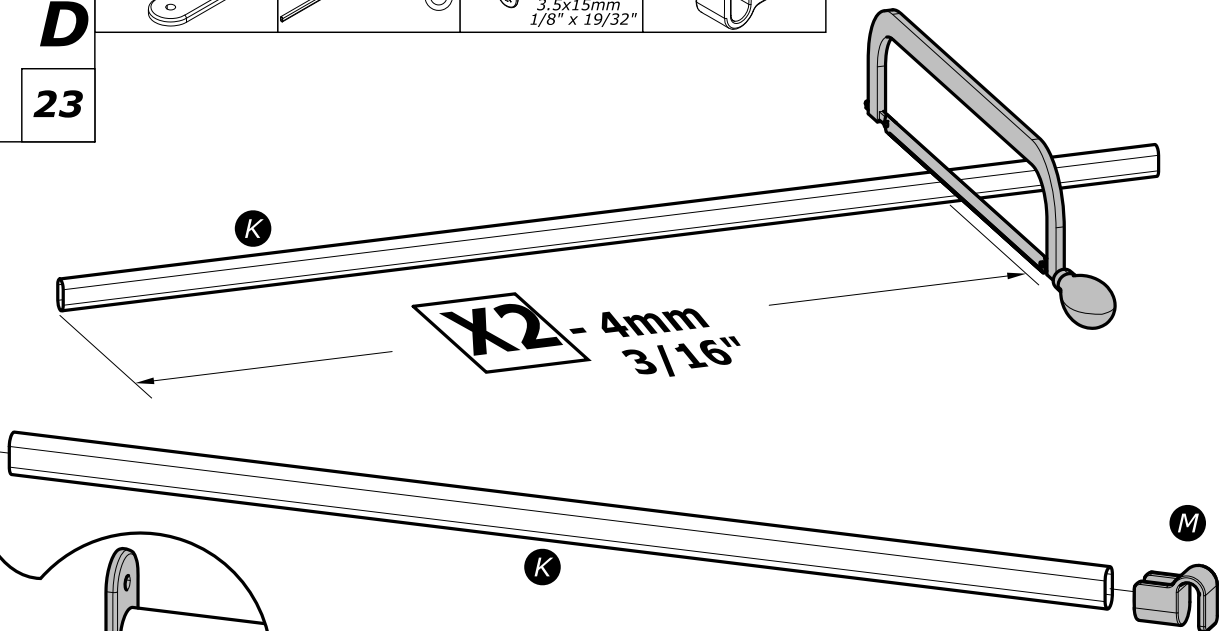
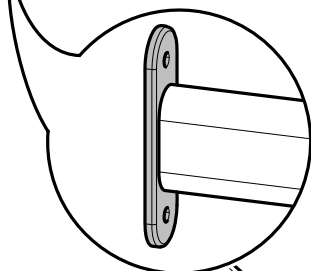
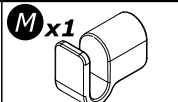
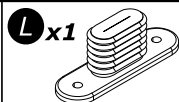

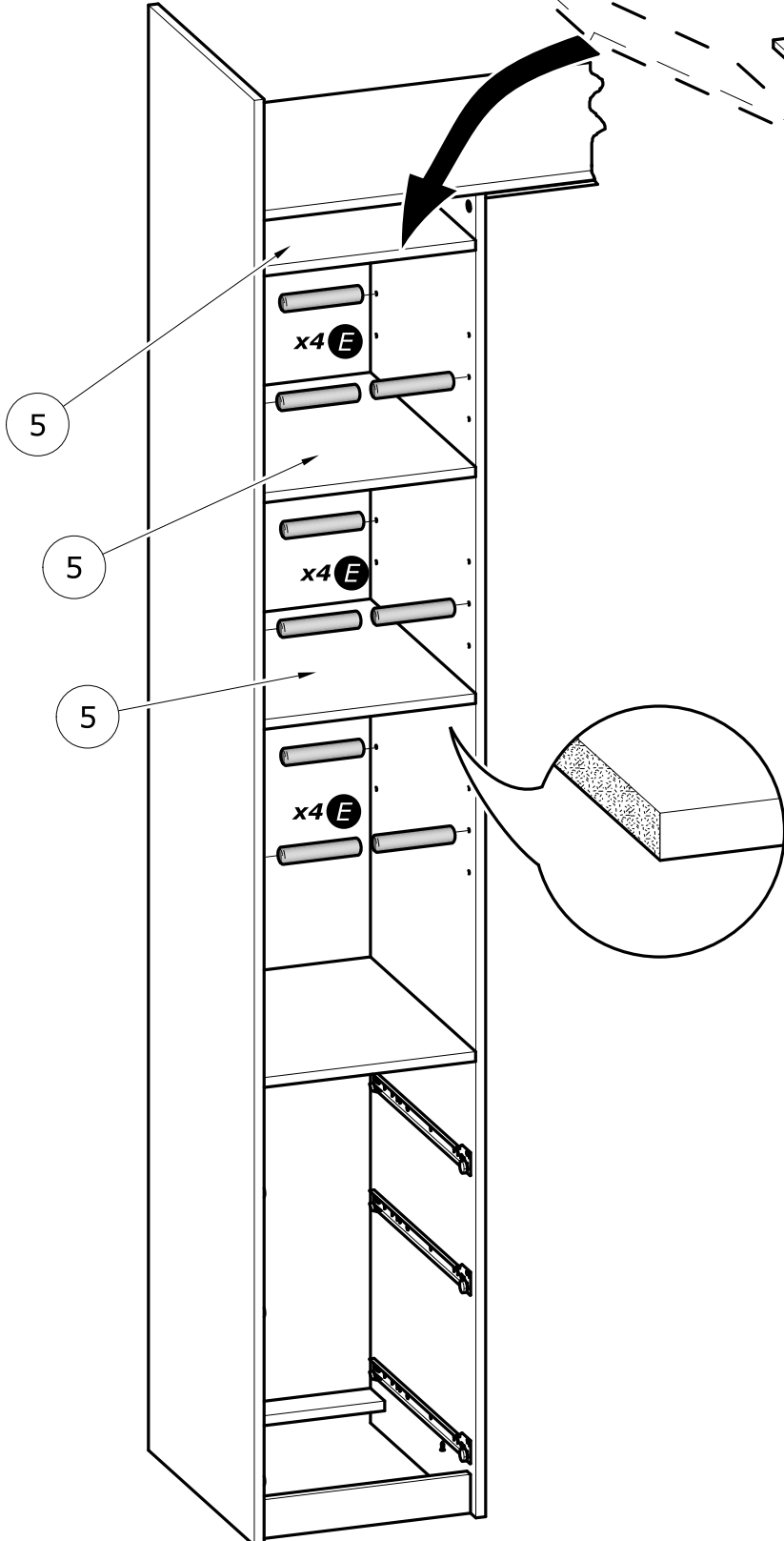
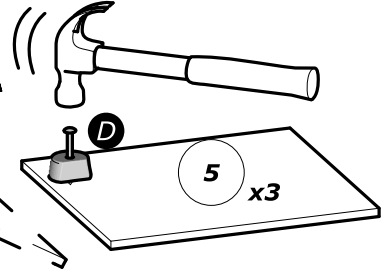
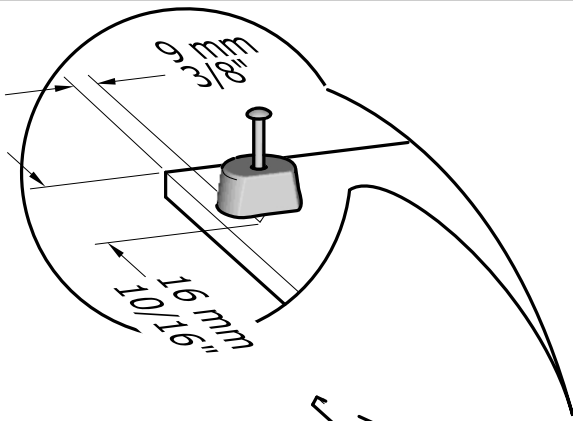
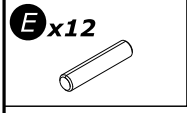
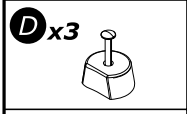
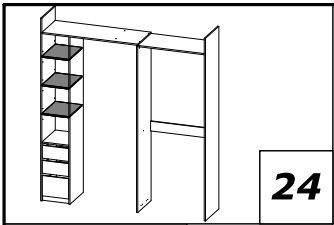

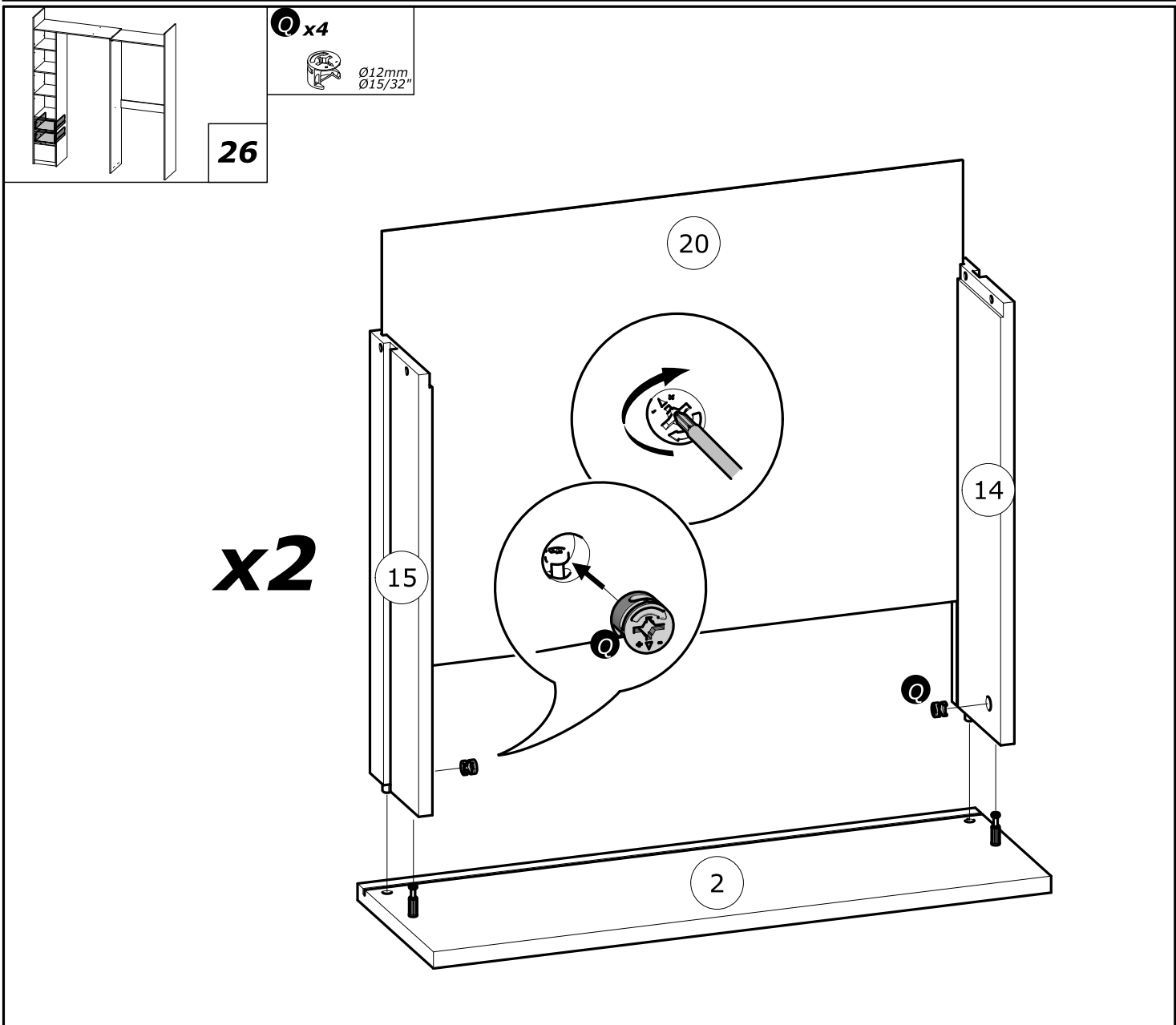
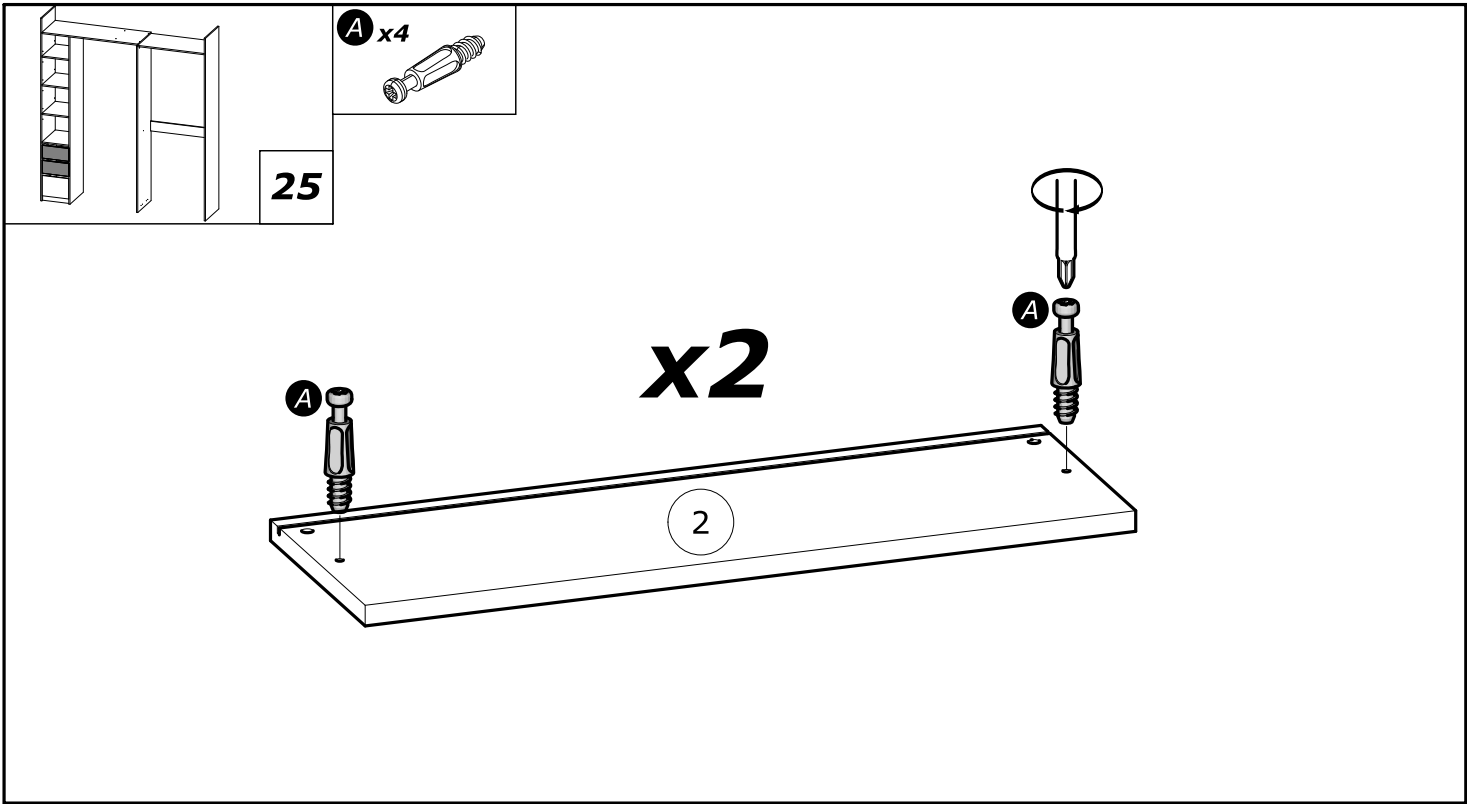

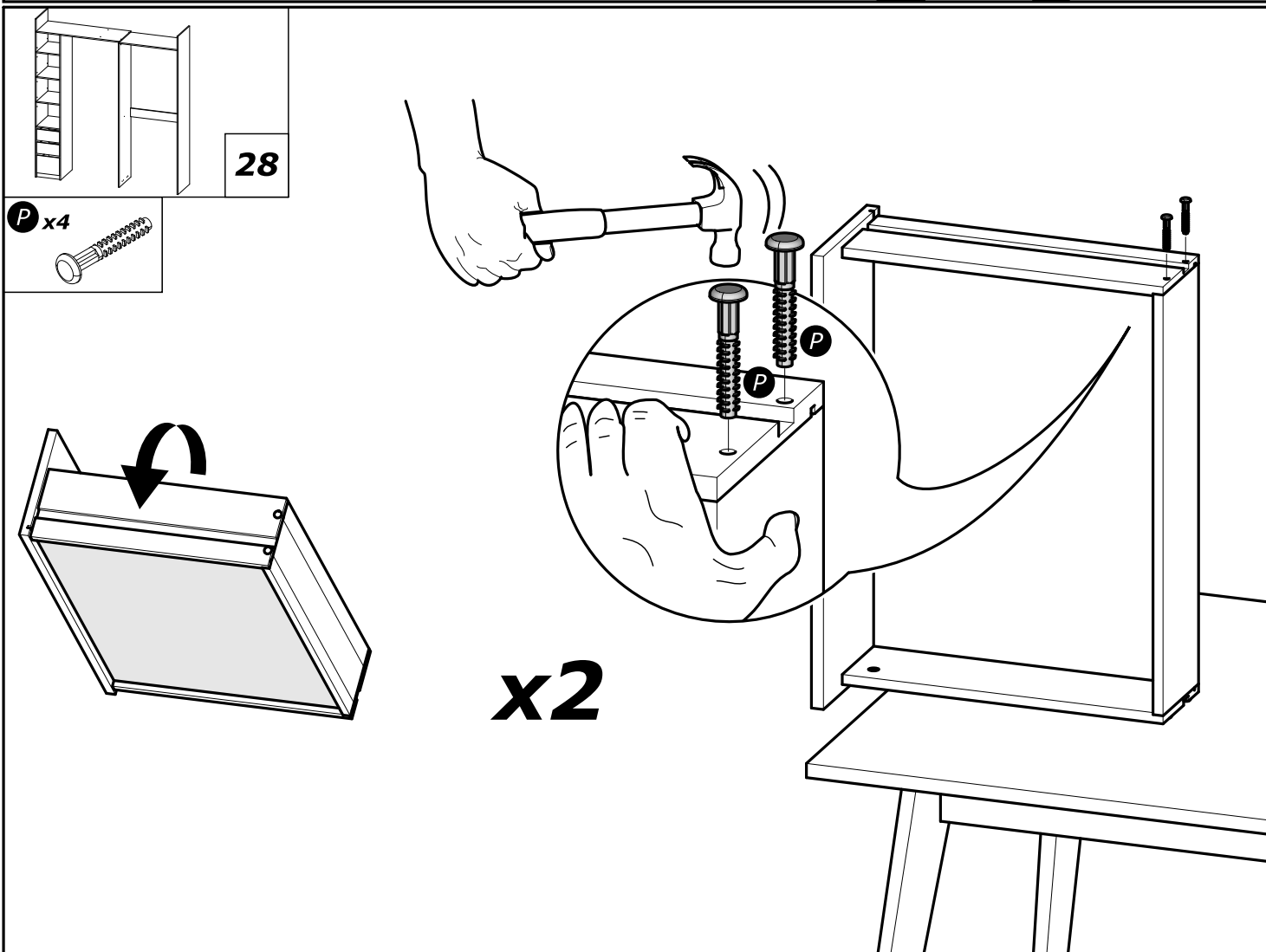
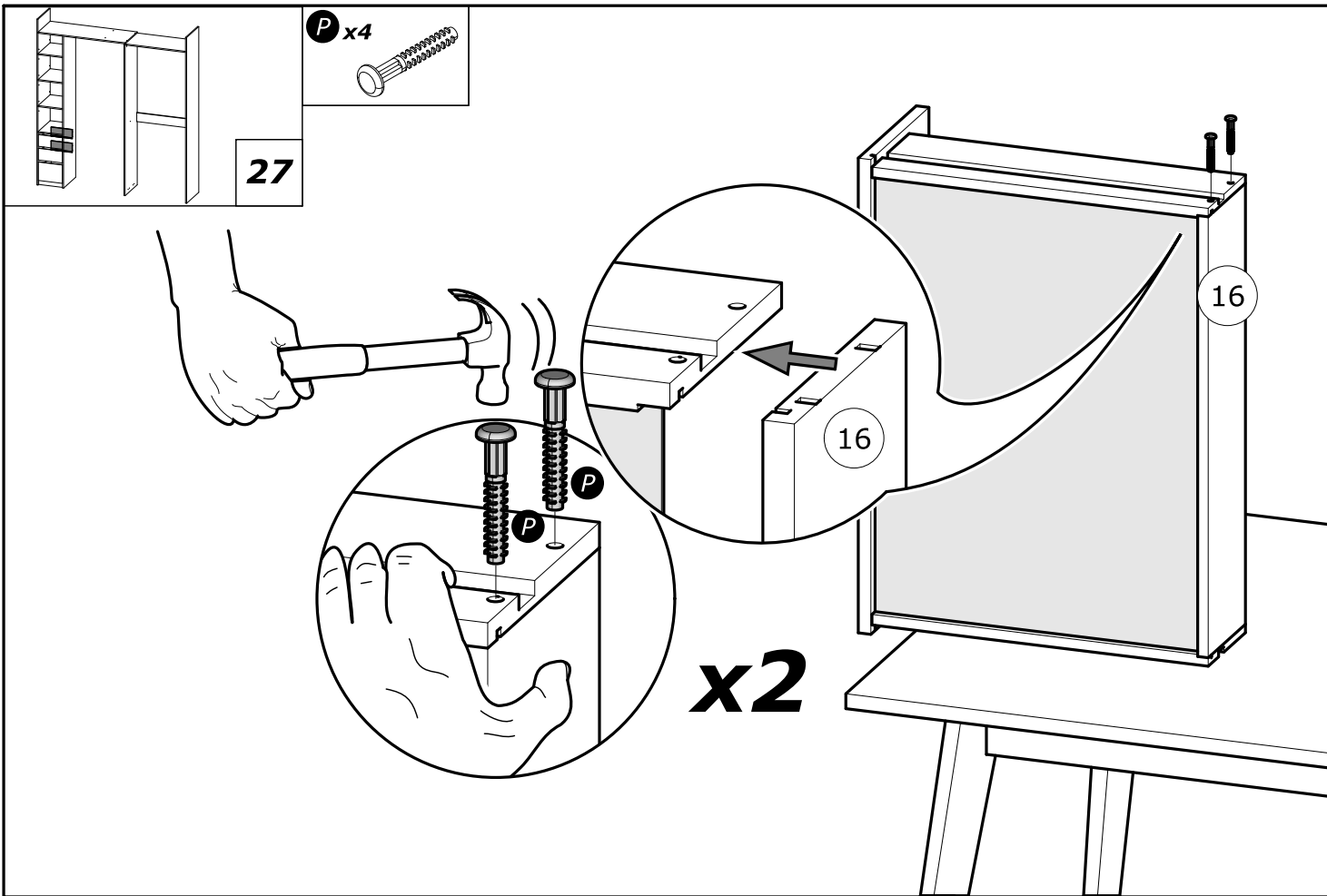

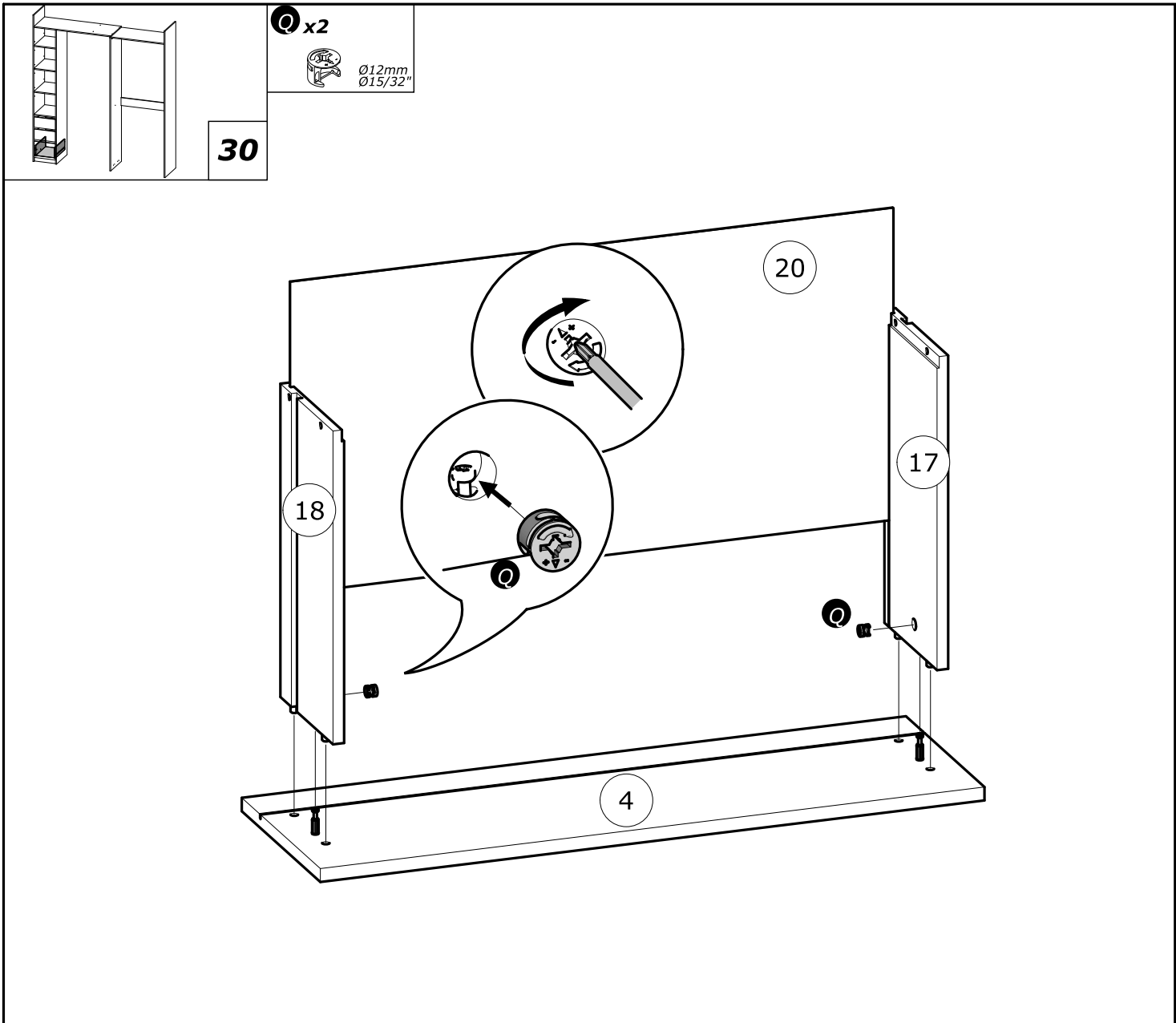
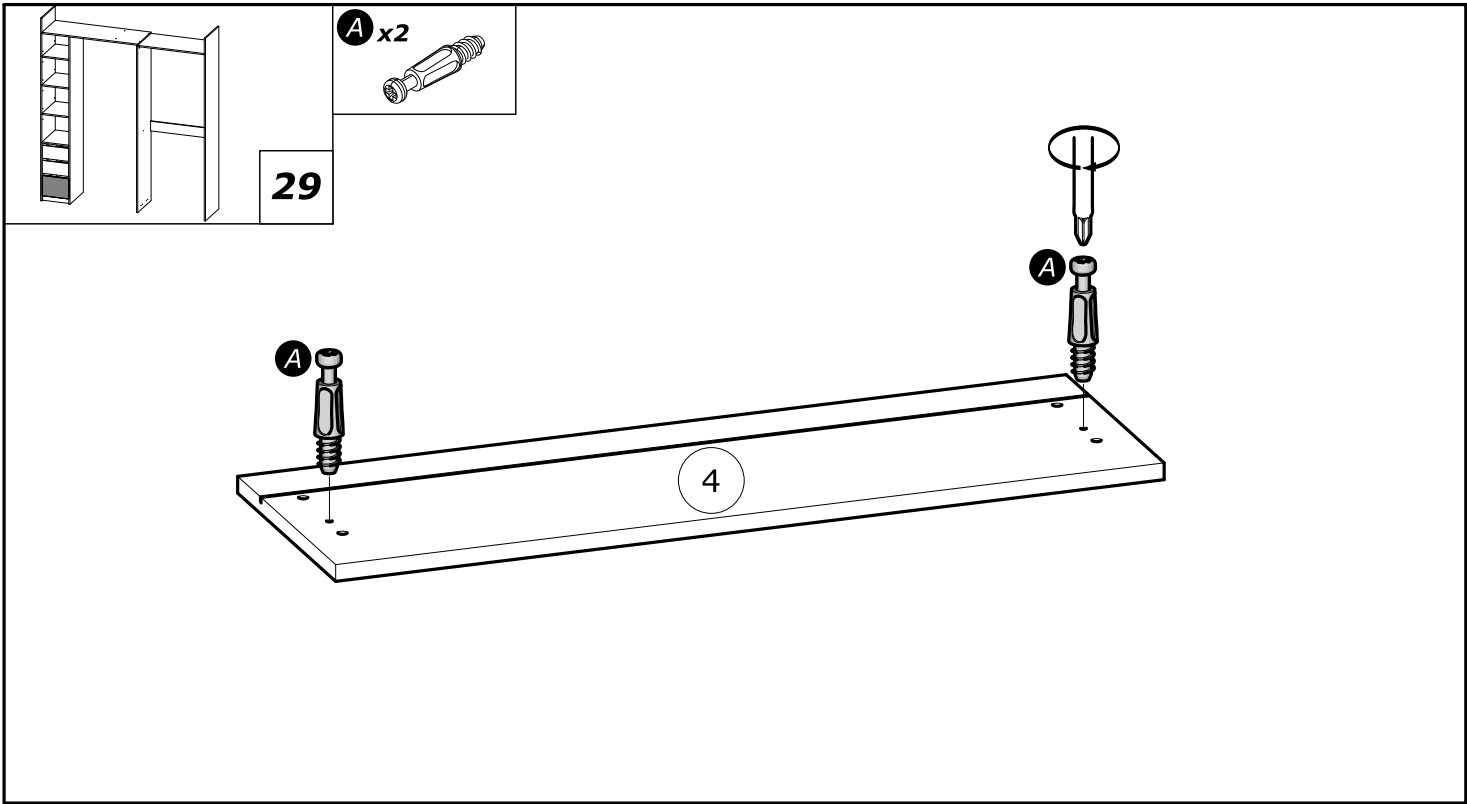

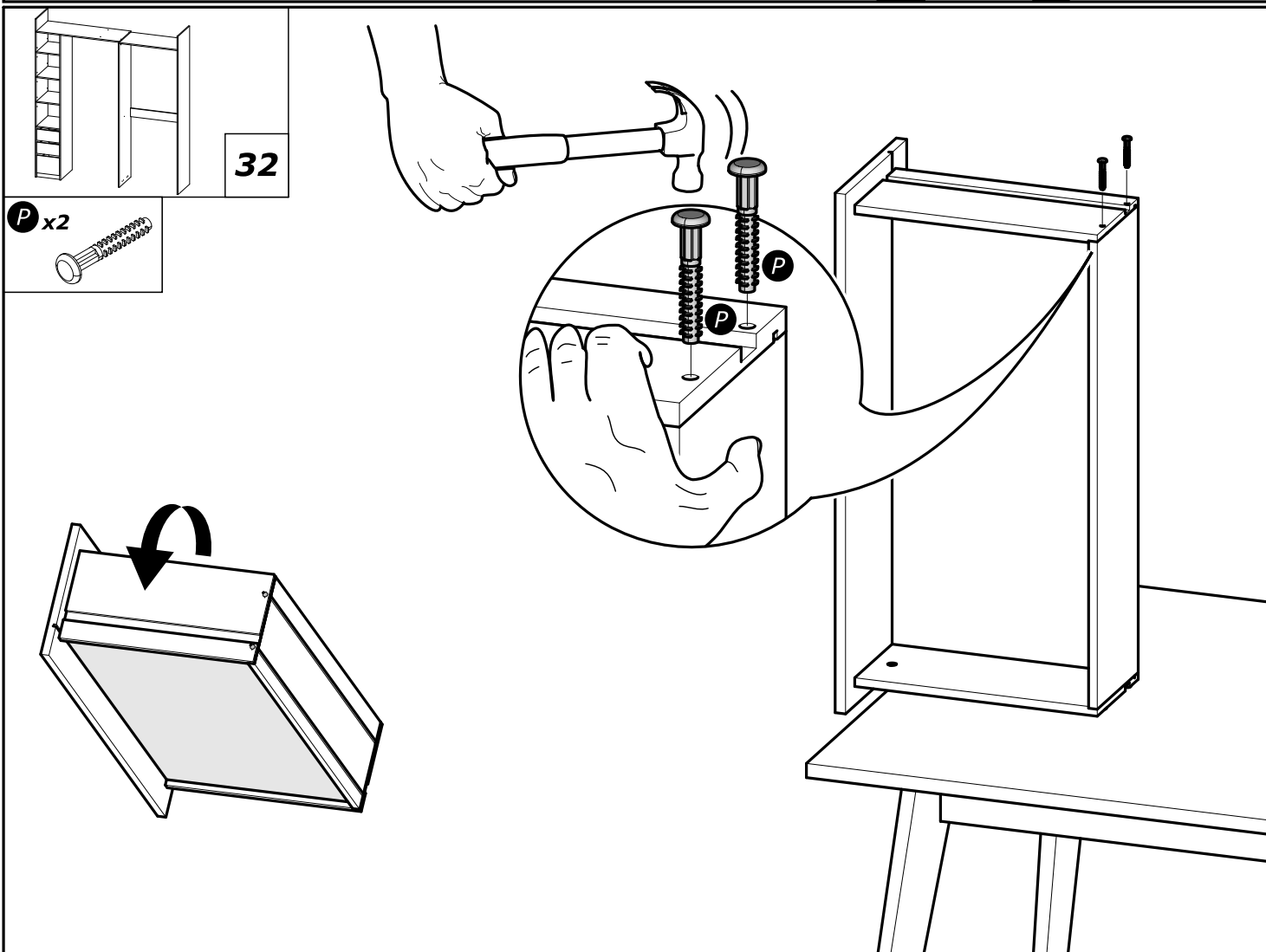
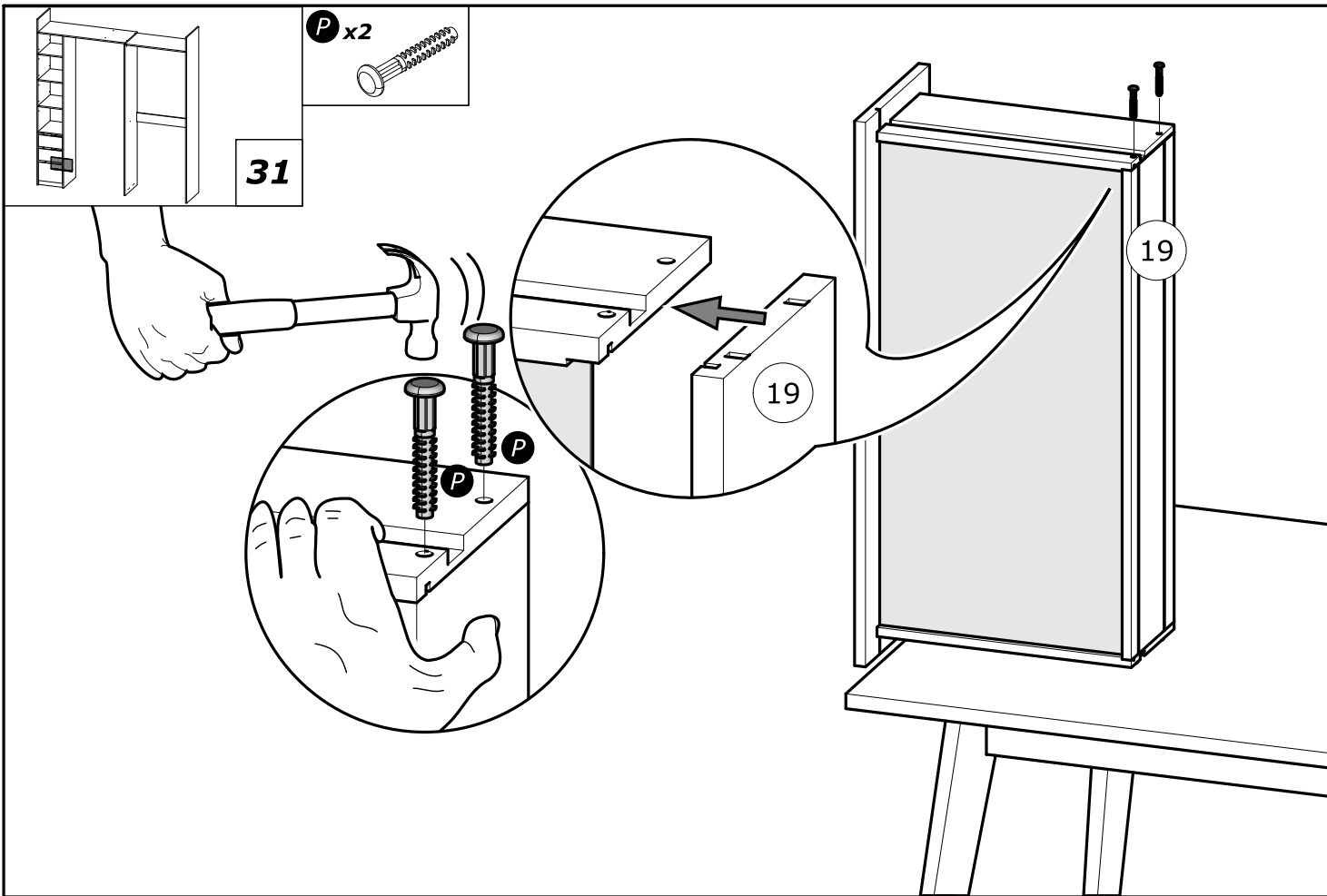

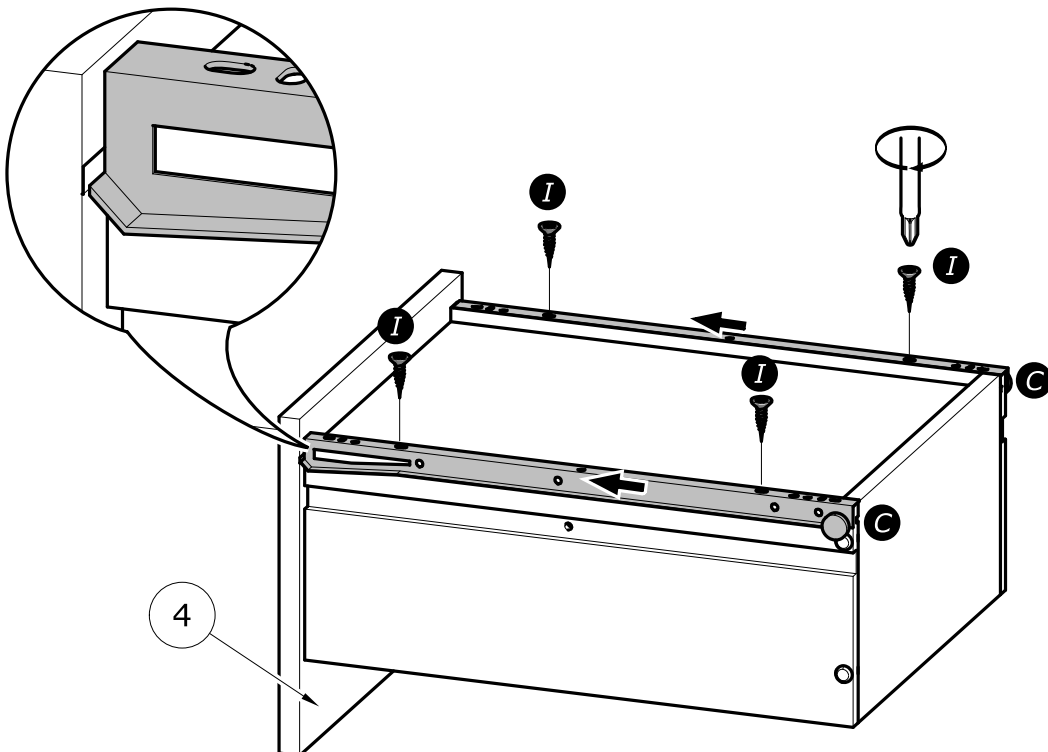
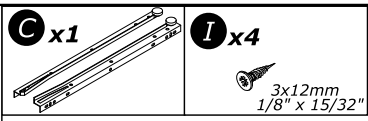
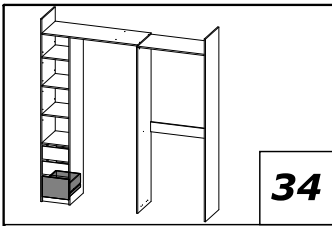
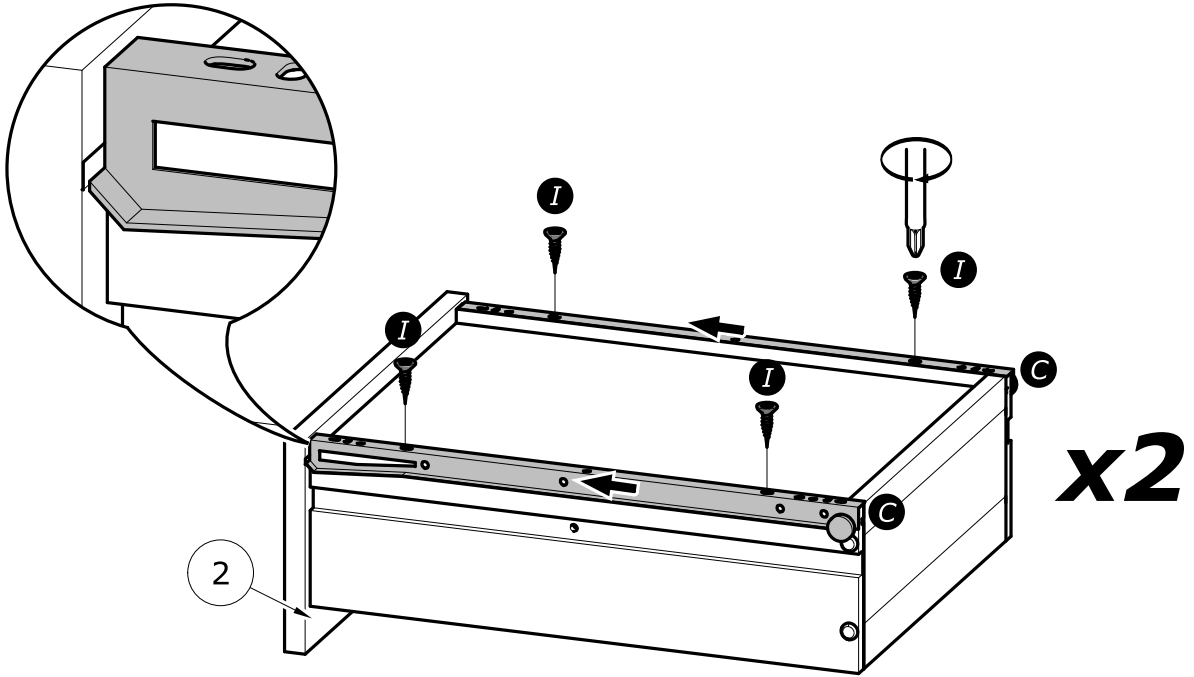
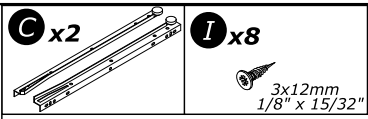
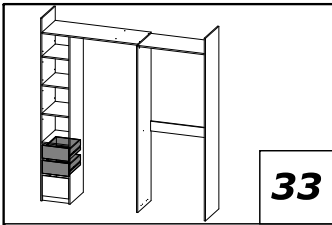

www.Demeyere.fr

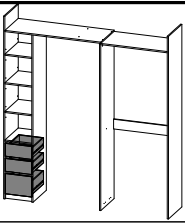

35



www.Demeyere.fr

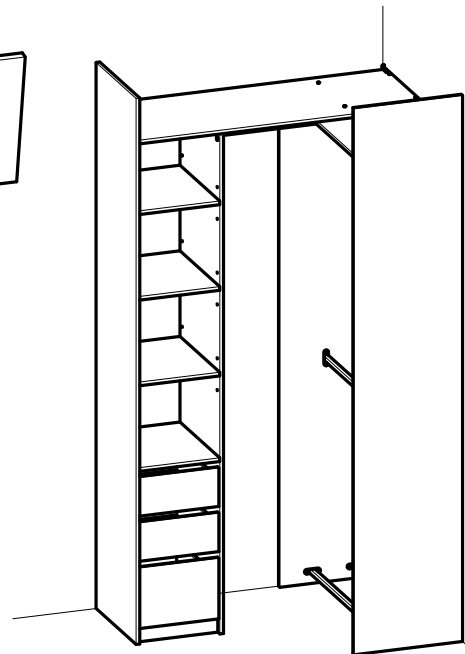
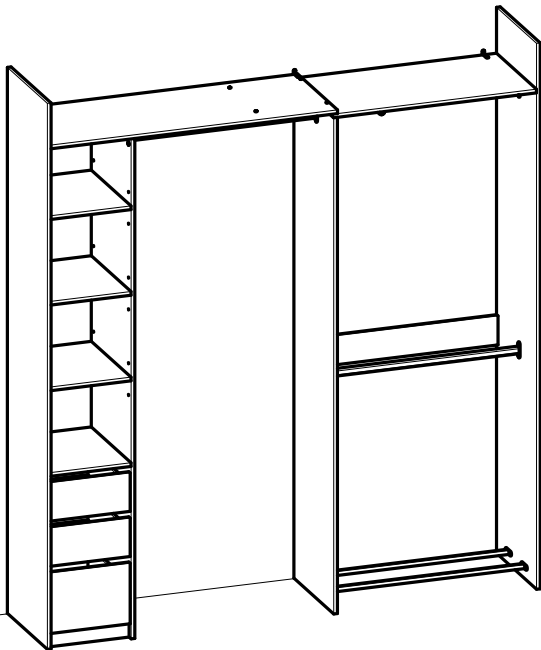
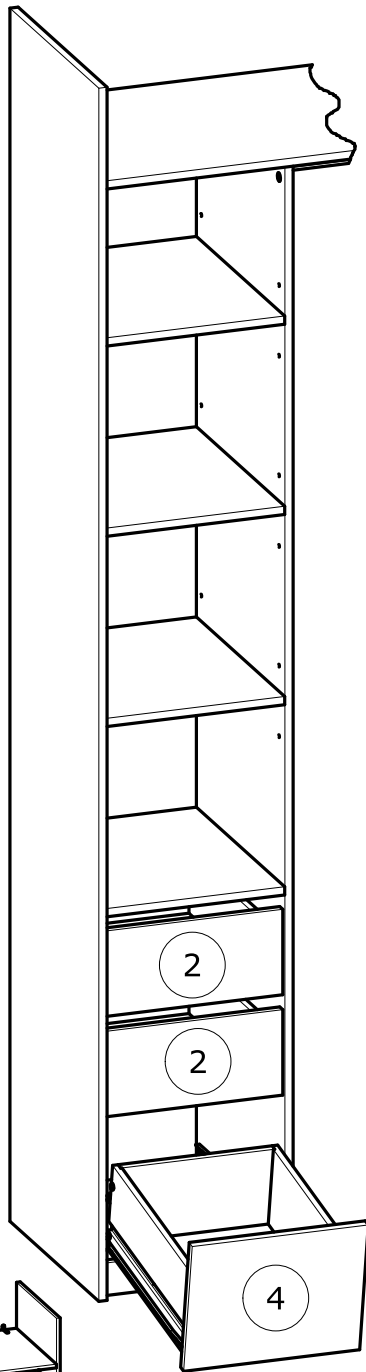

Info tri déchets

www.quefairedemesdechets.fr