

**Wardrobe 120/150/180**  
Video Assembling Instruction

**Kleiderschrank 120/150/180**  
Video Montageanleitung

**Szafa 120/150/180**  
Video Instrukcja montażu



PL składać w pozycji leżącej

EN assemble in a lying position

DE in Rückenlage montieren



SZAFKA 120, 150, 180

**PL> INSTRUKCJA MONTAŻU**  
**D > MONTAGEANLEITUNG**  
**GB> ASSEMBLY INSTRUCTIONS**

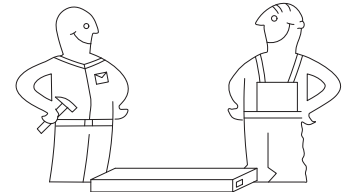

Tools required narzędzia wymagane Werkzeuge erforderlich

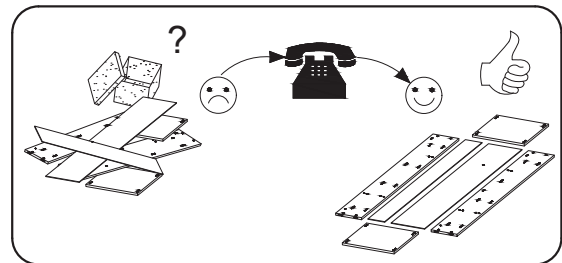
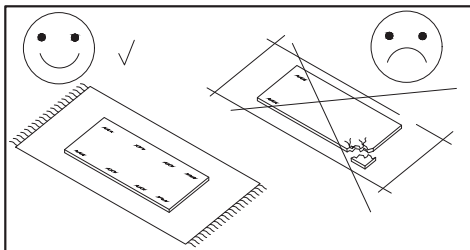
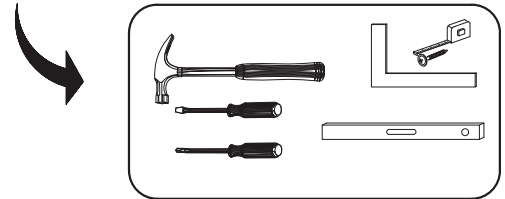
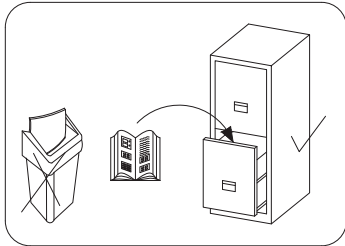

**Uwaga / Achtung / Caution**

**PL>** Czyszczenie należy wykonać wyłącznie za pomocą ściereczki lub lekko nawilżonego ręcznika.  
 Nie stosować środków czyszczących do szorowania.

Szanowny kliencie, jeśli podczas montażu stwierdzisz uszkodzenie lub brak części, proszę podaj jej kod alfanumeryczny lub zaznacz ją na instrukcji montażu i prześlij wraz z protokołem reklamacyjnym

**D >** Bitte nur mit einem Staubtuch oder leicht feuchtem Lappen reinigen. Keine scheuerenden Putzmittel verwenden.

Sehr geehrter Kunde, sollte ein Teil fehlen oder beschädigt sein, kreuzen Sie dies bitte deutlich auf der Montageanleitung an und schicken Sie die Montageanleitung mit ein.

**GB>** Please only clean with a duster or a damp cloth. Do not use any abrasive cleaners.

Dear customer, should there be any piece missing or damaged, kindly mark this piece clearly on the attached assembly instructions and return them to us.

**Karta serwisowa / Service Karte / Service card**

AKCESORIA / ZUBEHÖR / ACCESSORIES

D  38	A  28	B  28	C  28	E  8	N  2	G  2	W3,5x13  H 4
L  10	M  10	F  10	W3x16  1	TF  1	LH  1	D1  J1 2	W4x30  K 4

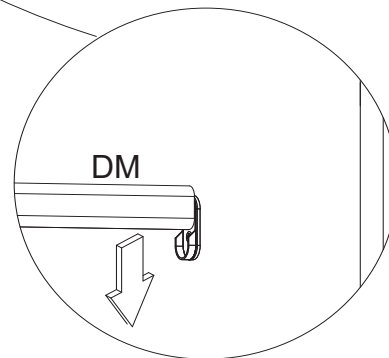
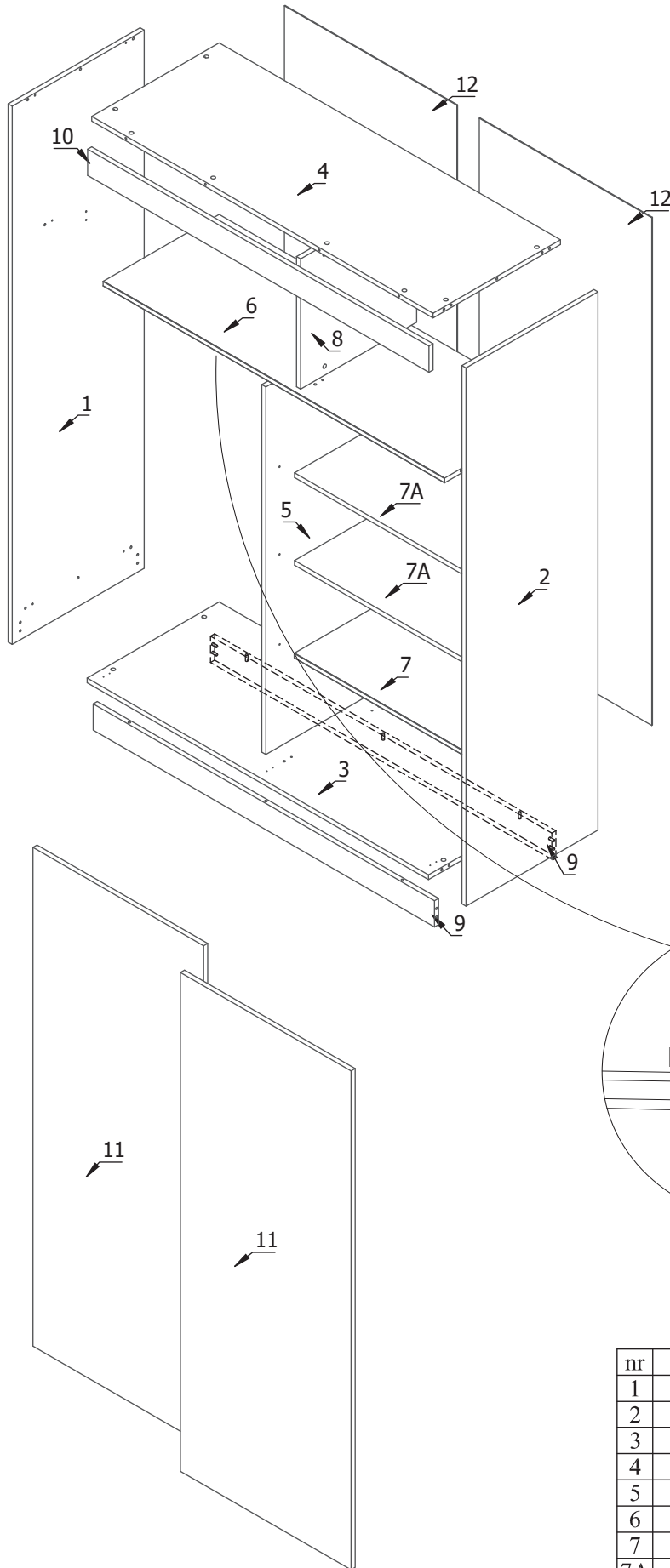
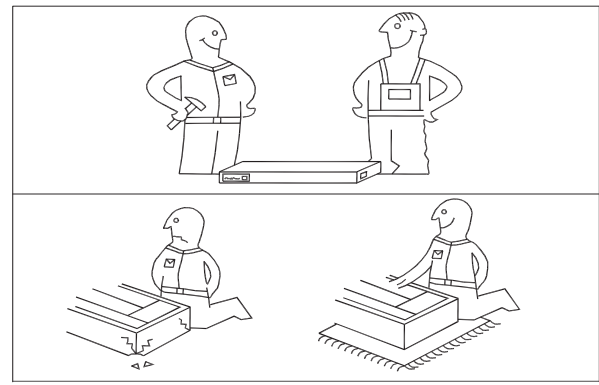

nr	Szafa 180	Szafa 150	Szafa 120
1	2150 x 581	2000 x 581	2000 x 581
2	2150 x 581	2000 x 581	2000 x 581
3	1768 x 581	1468 x 581	1168 x 581
4	1768 x 565	1468 x 565	1168 x 565
5	1644 x 475	1494 x 475	1494 x 475
6	1768 x 475	1468 x 475	1168 x 475
7	876 x 475	726 x 475	576 x 475
7A	876 x 475	726 x 475	576 x 475
8	357 x 475	357 x 475	357 x 475
9	1768 x 100	1468 x 100	1168 x 100
10	1768 x 70	1468 x 70	1168 x 70
11	2004 x 900	1853 x 753	1853 x 600
12	2040 x 899	1895 x 748	1895 x 598



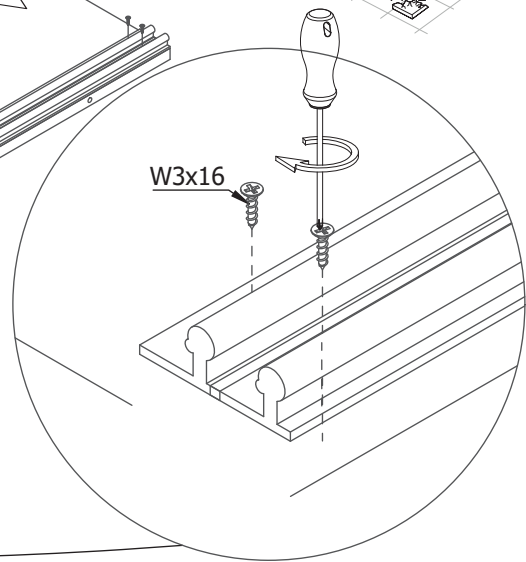
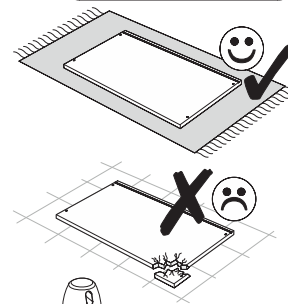
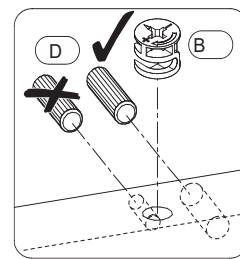
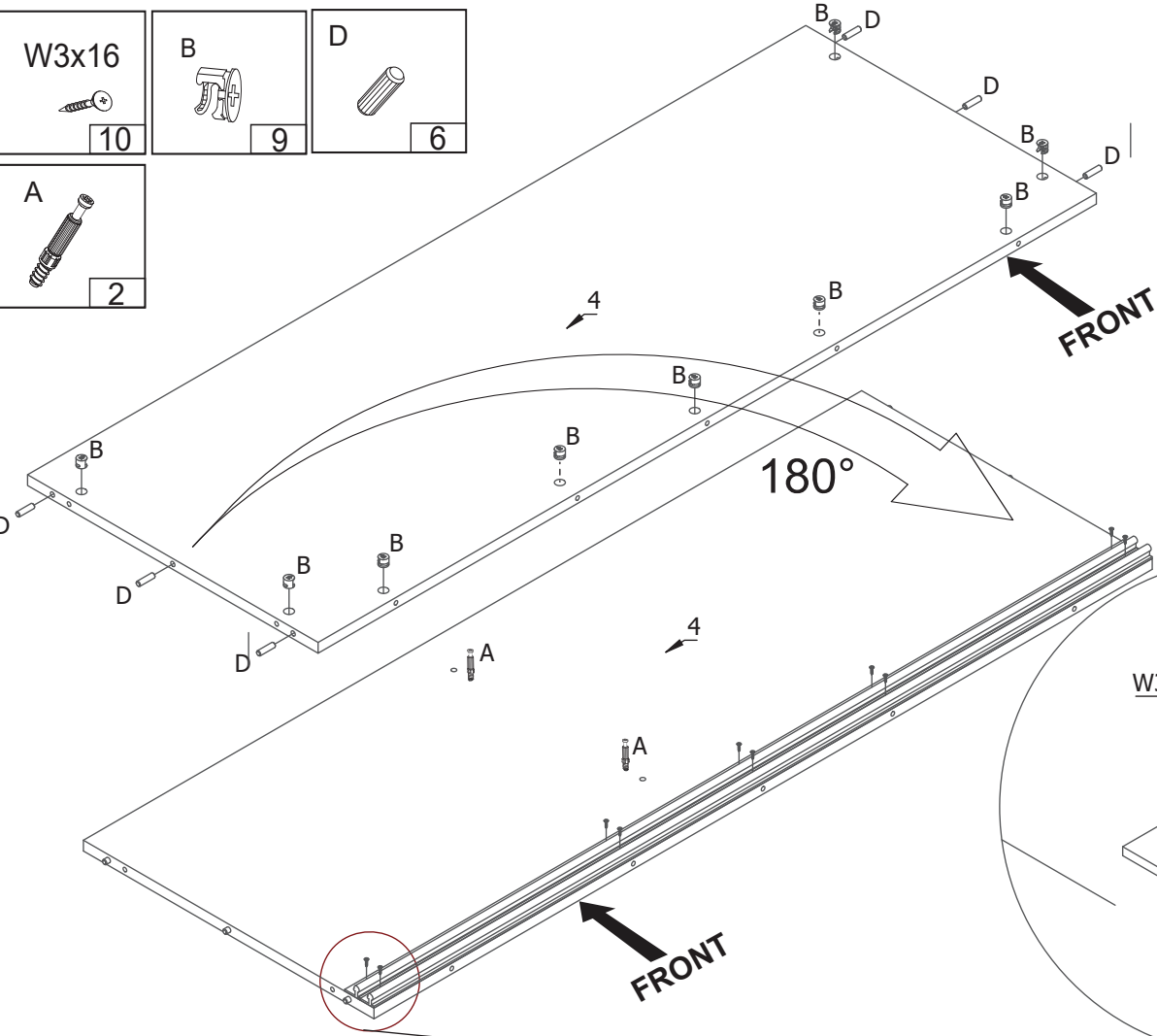
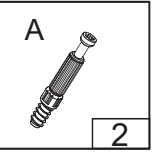
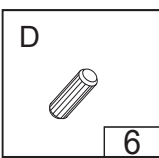
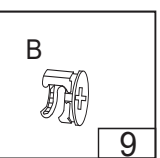
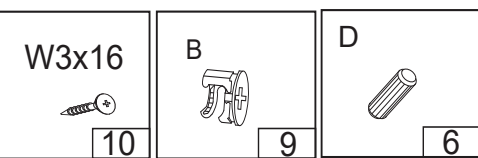
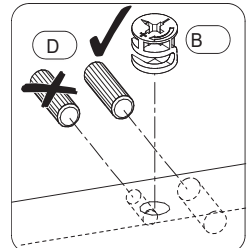
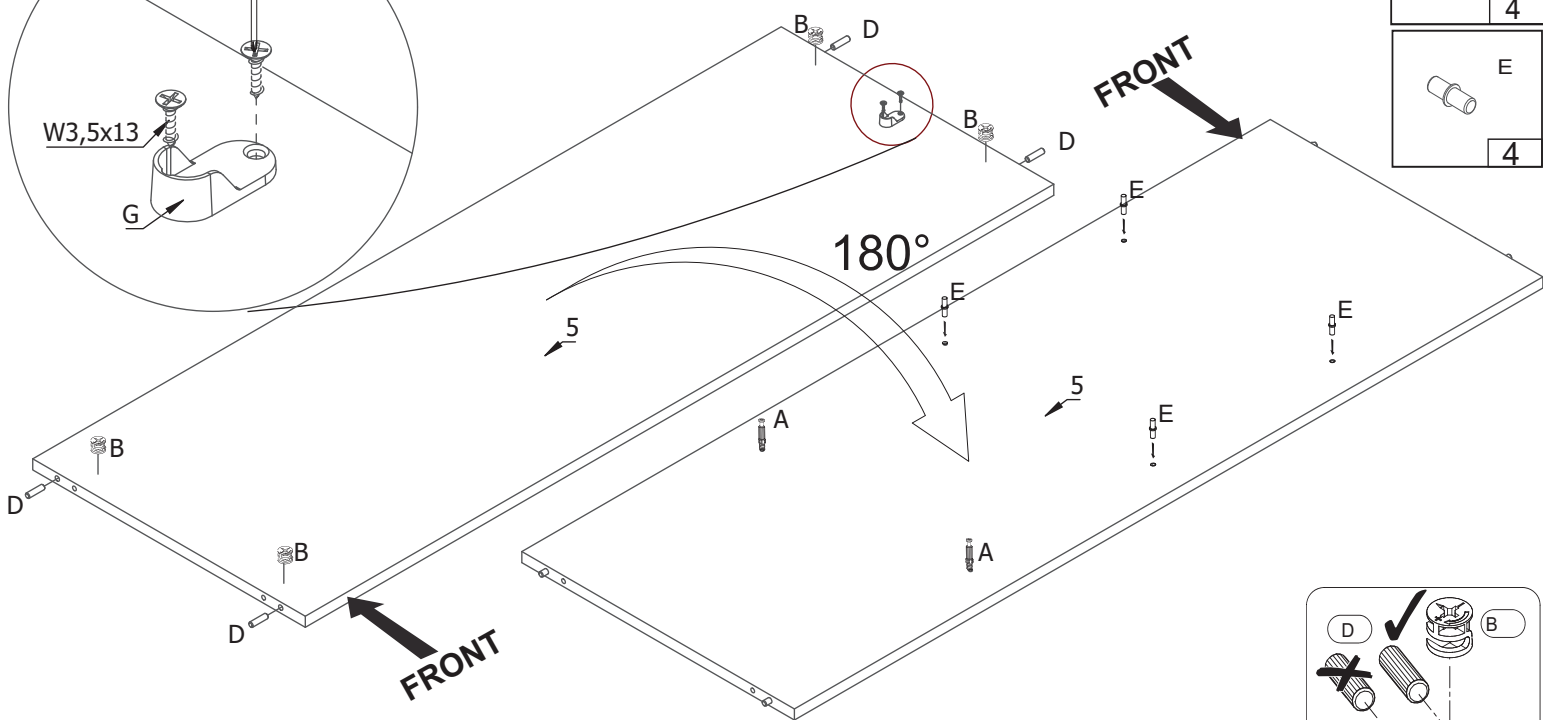
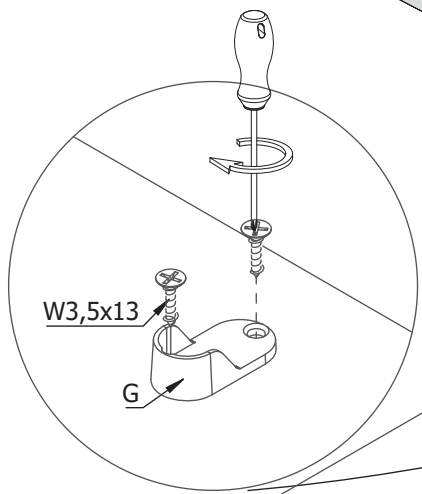
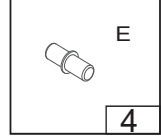
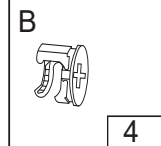
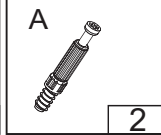
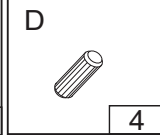
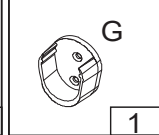
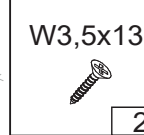
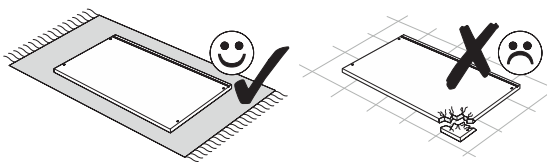



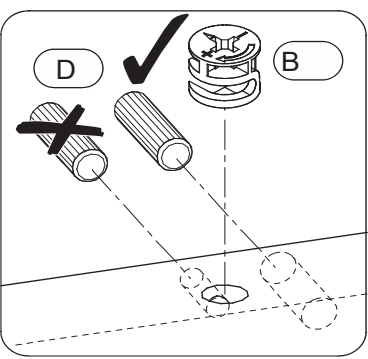
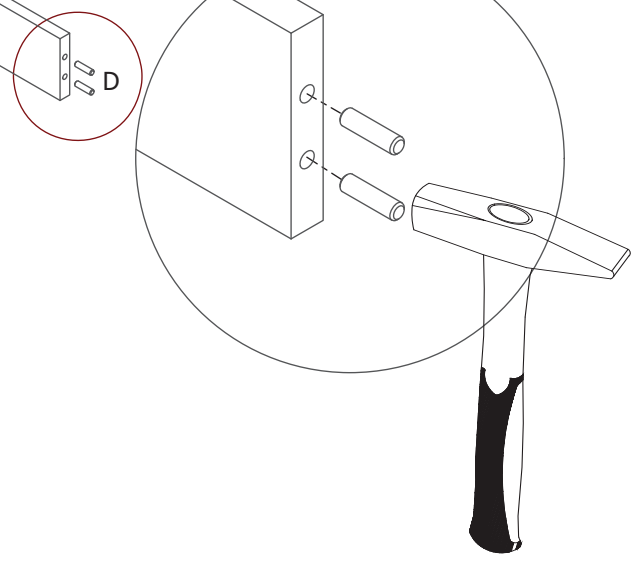
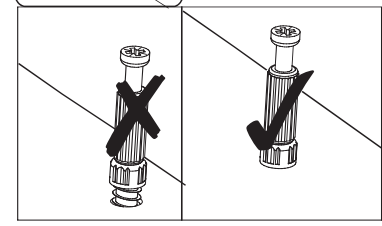
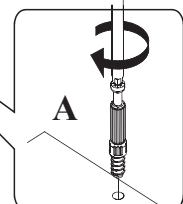
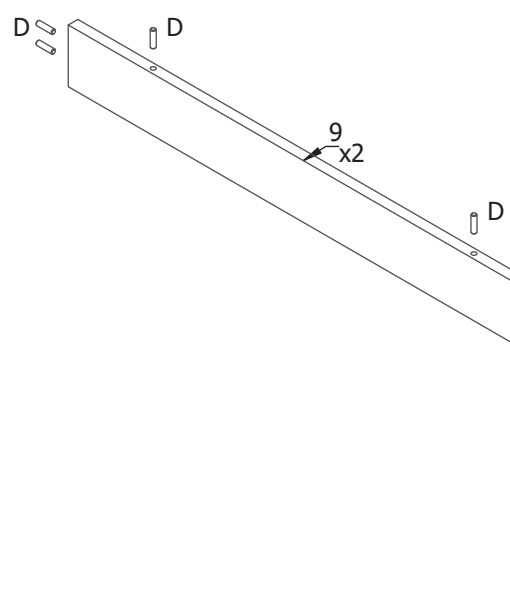
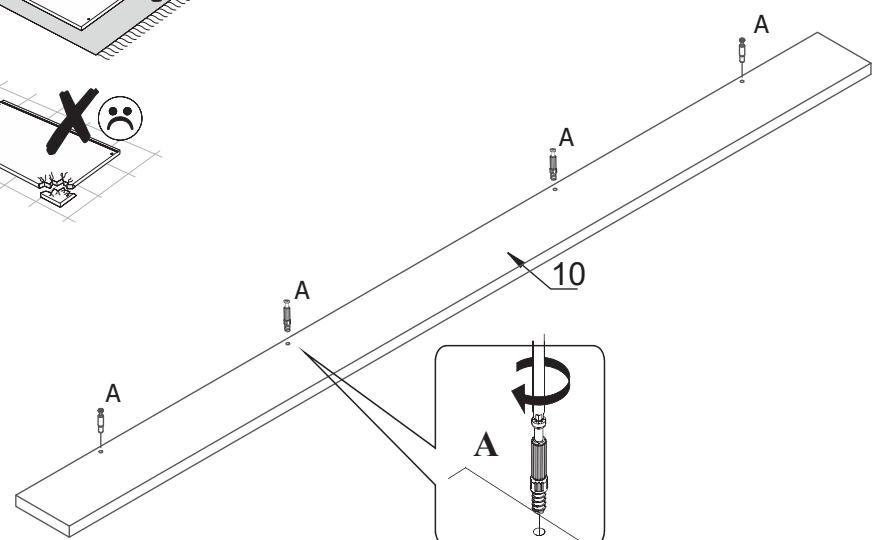
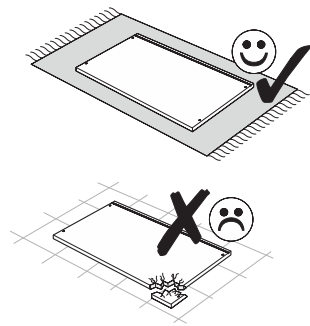
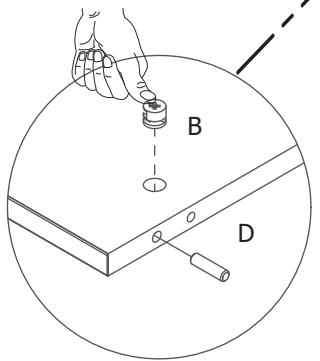
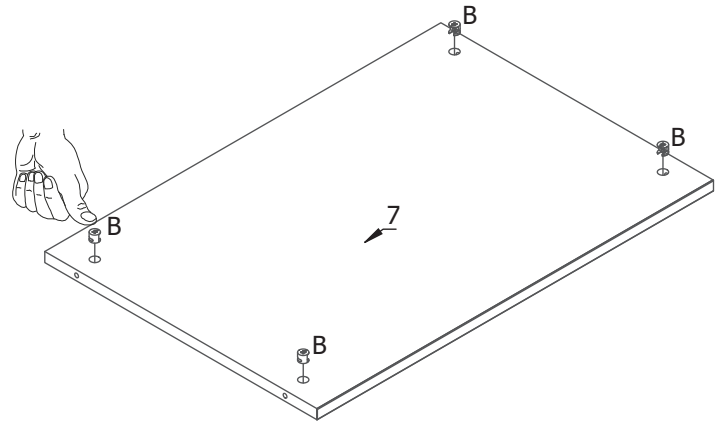
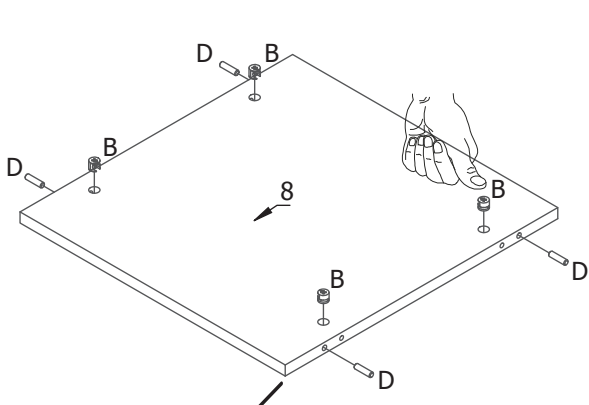
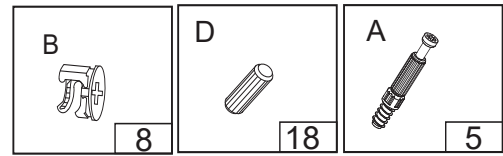



PL składać w pozycji leżącej  
 EN assemble in a lying position  
 DE in Rückenlage montieren

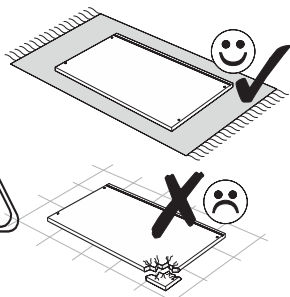
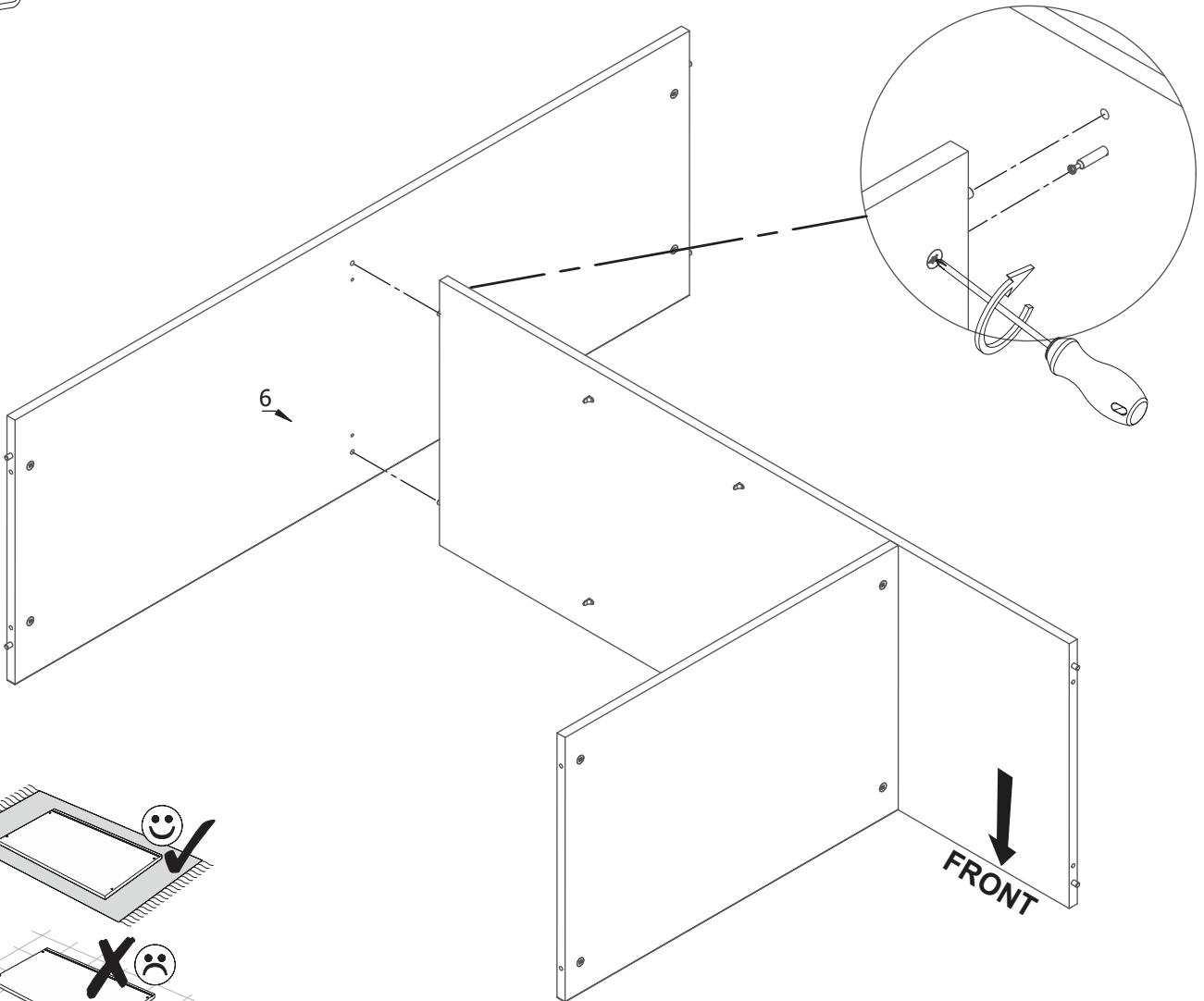
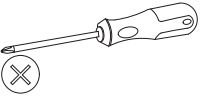
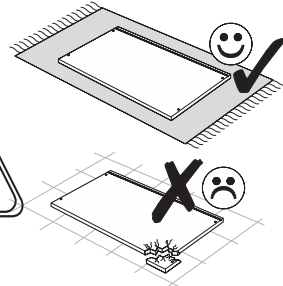
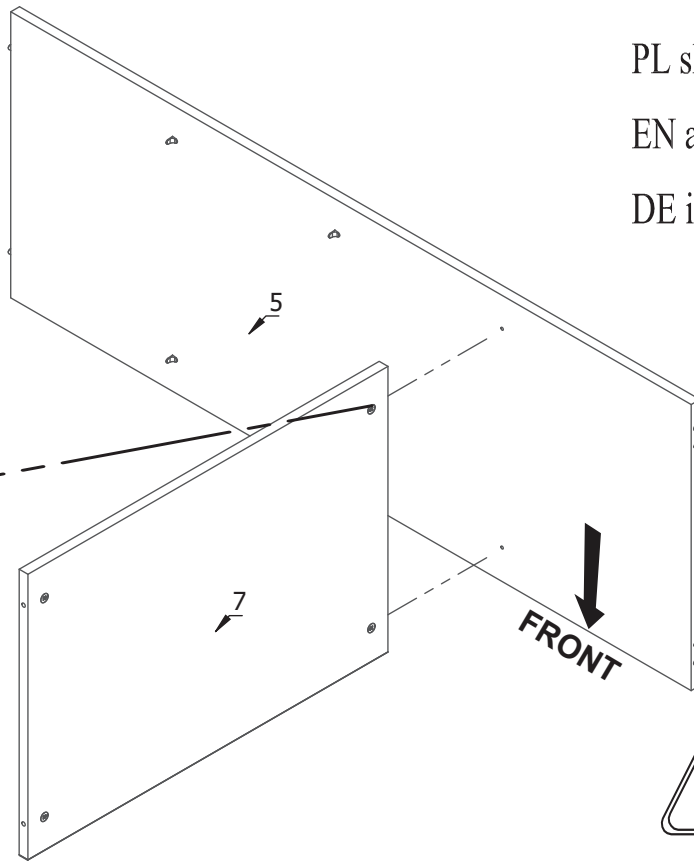
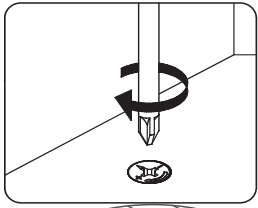
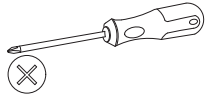



PL składać w pozycji leżącej  
EN assemble in a lying position  
DE in Rückenlage montieren

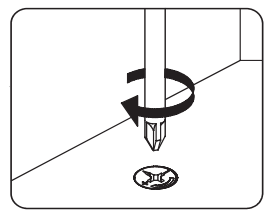
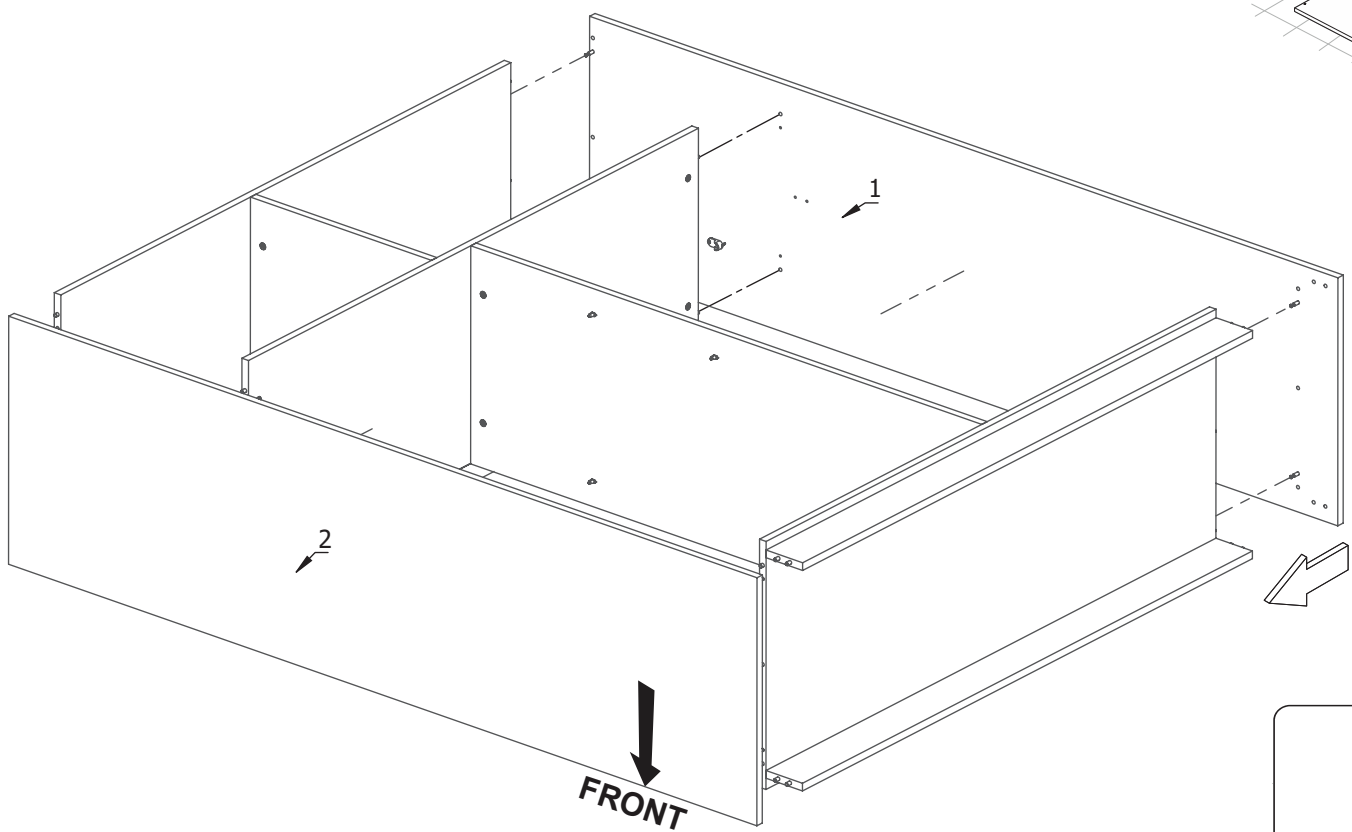
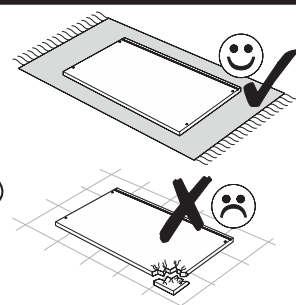
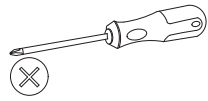
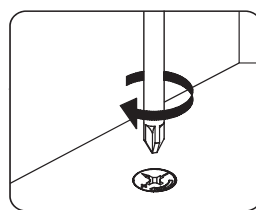
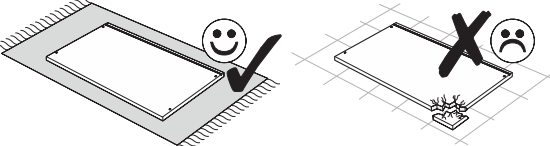
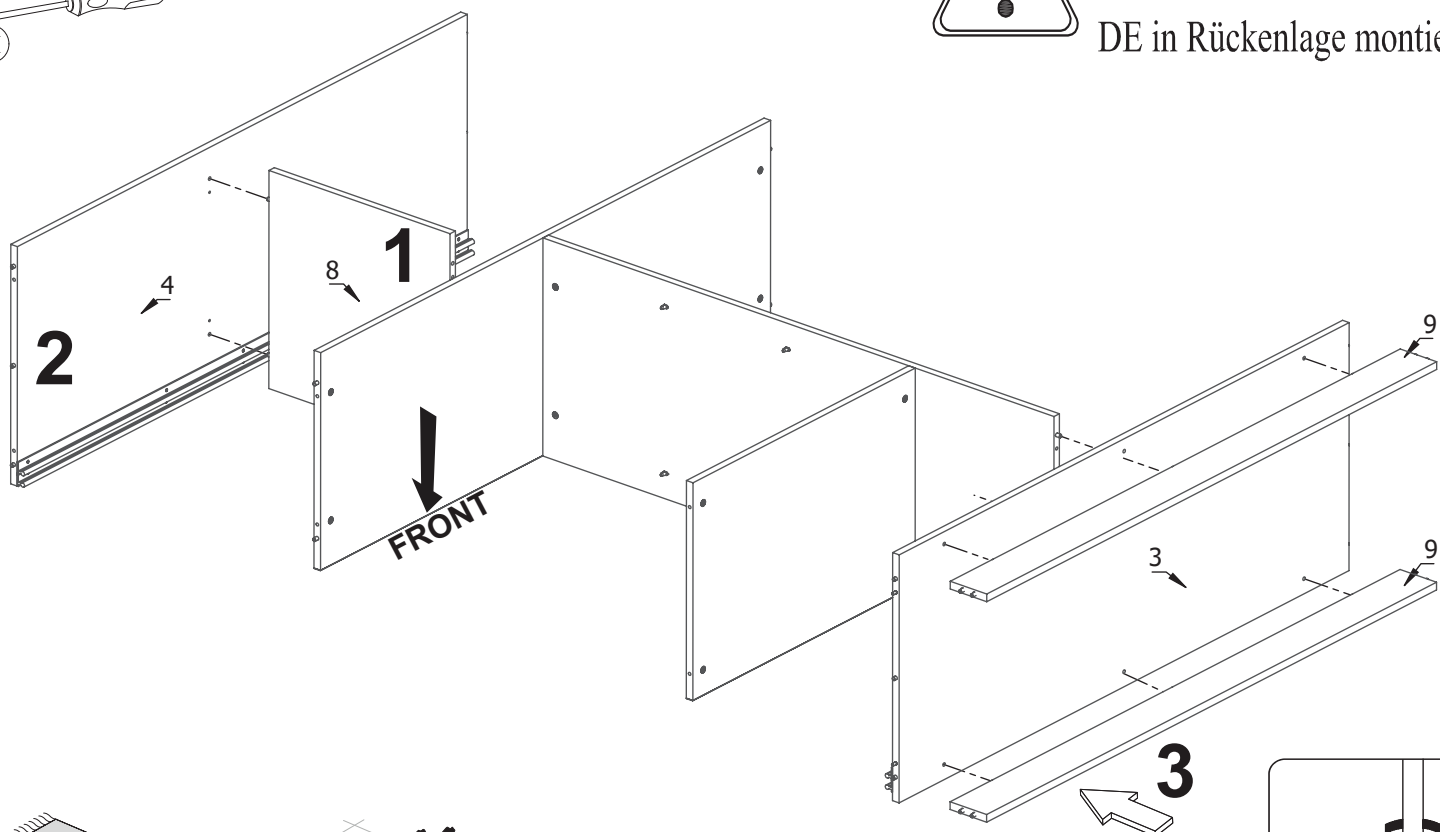
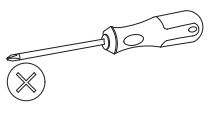

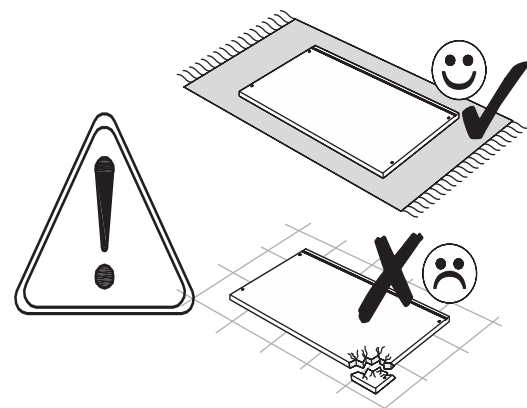
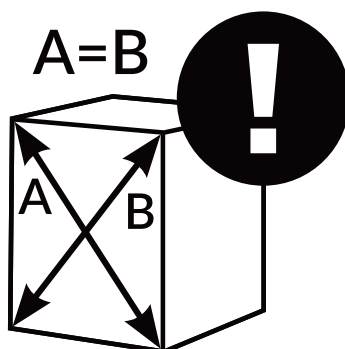
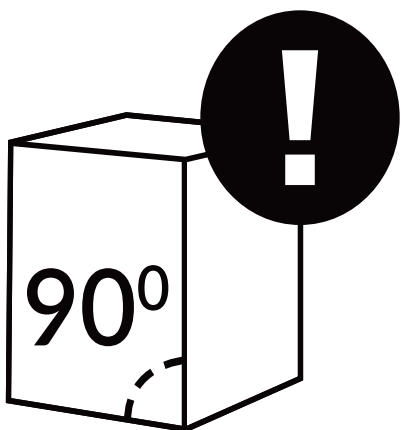
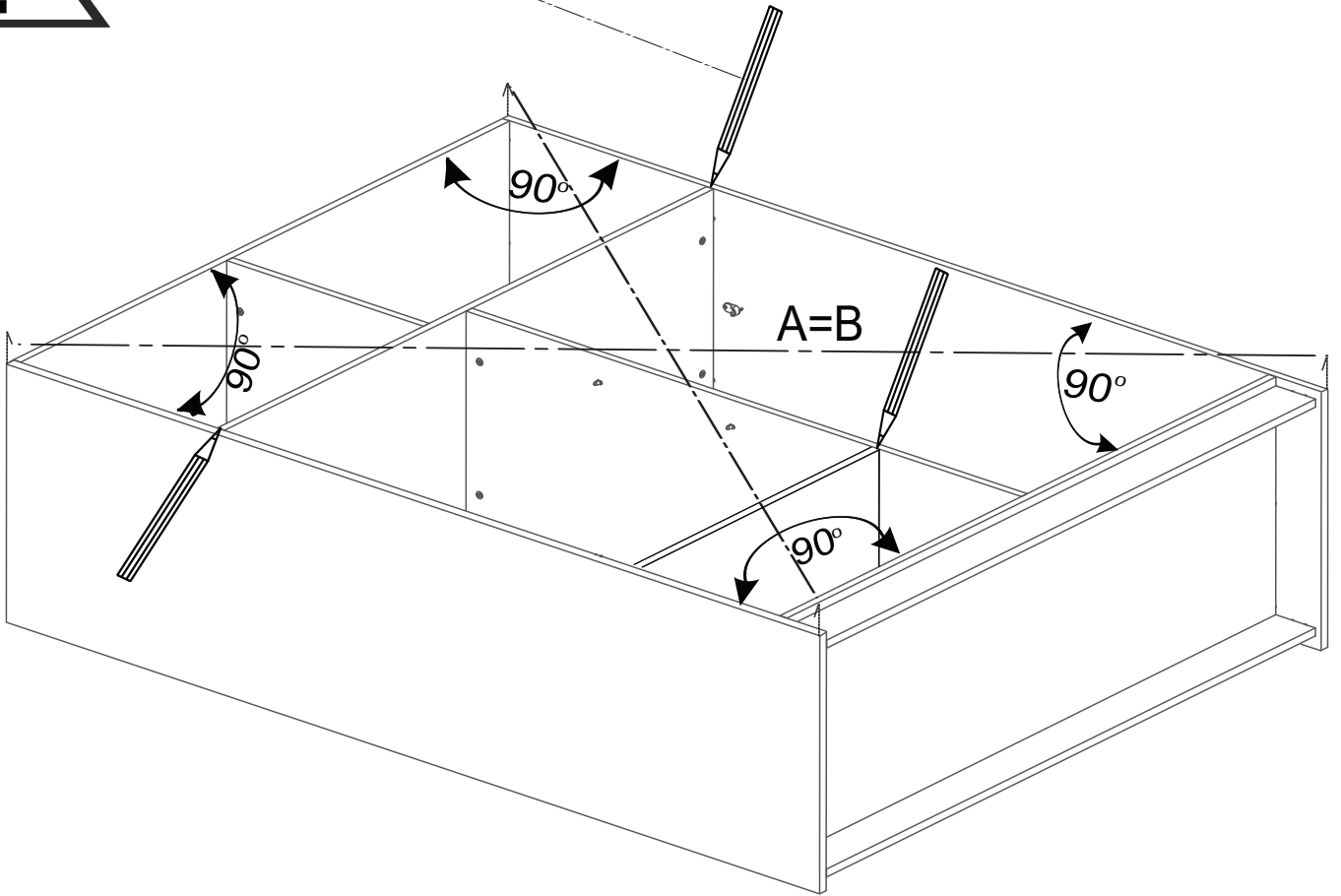
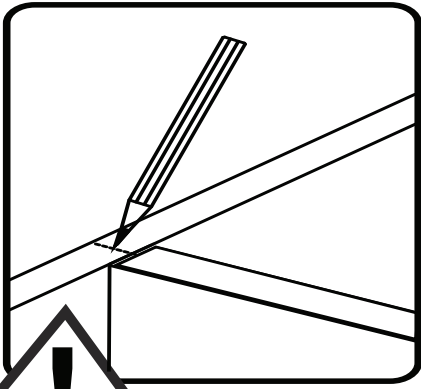
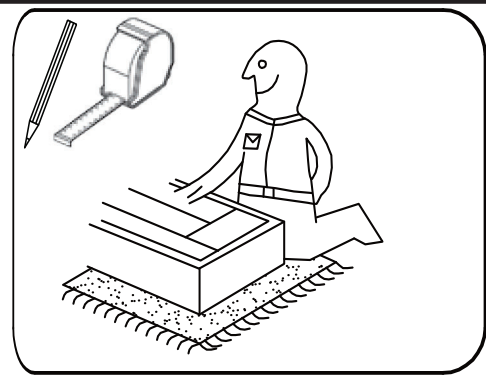

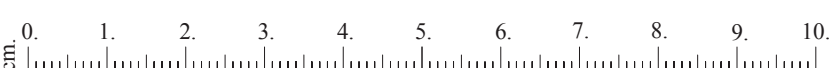
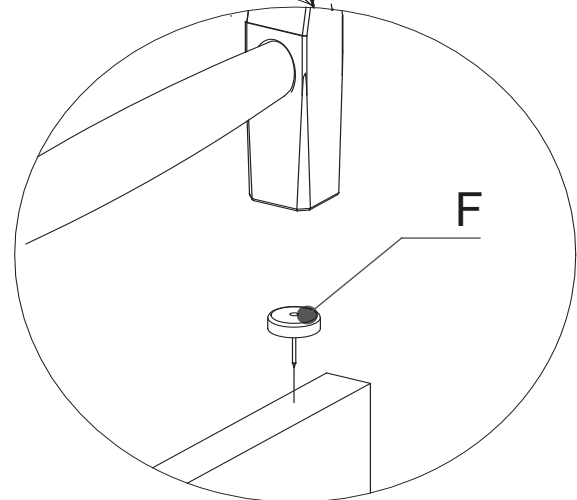
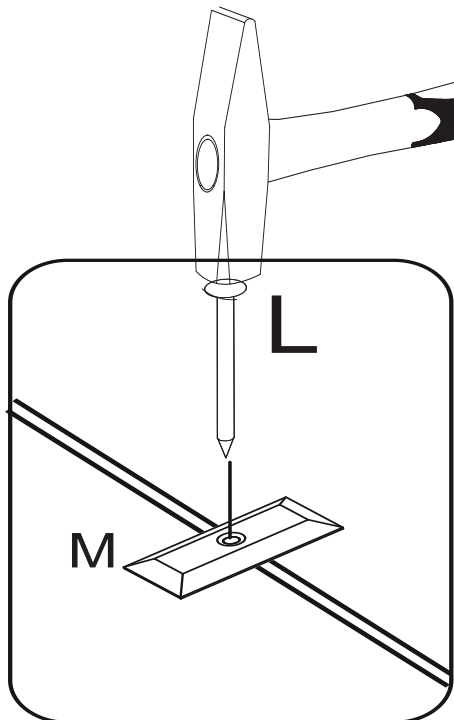
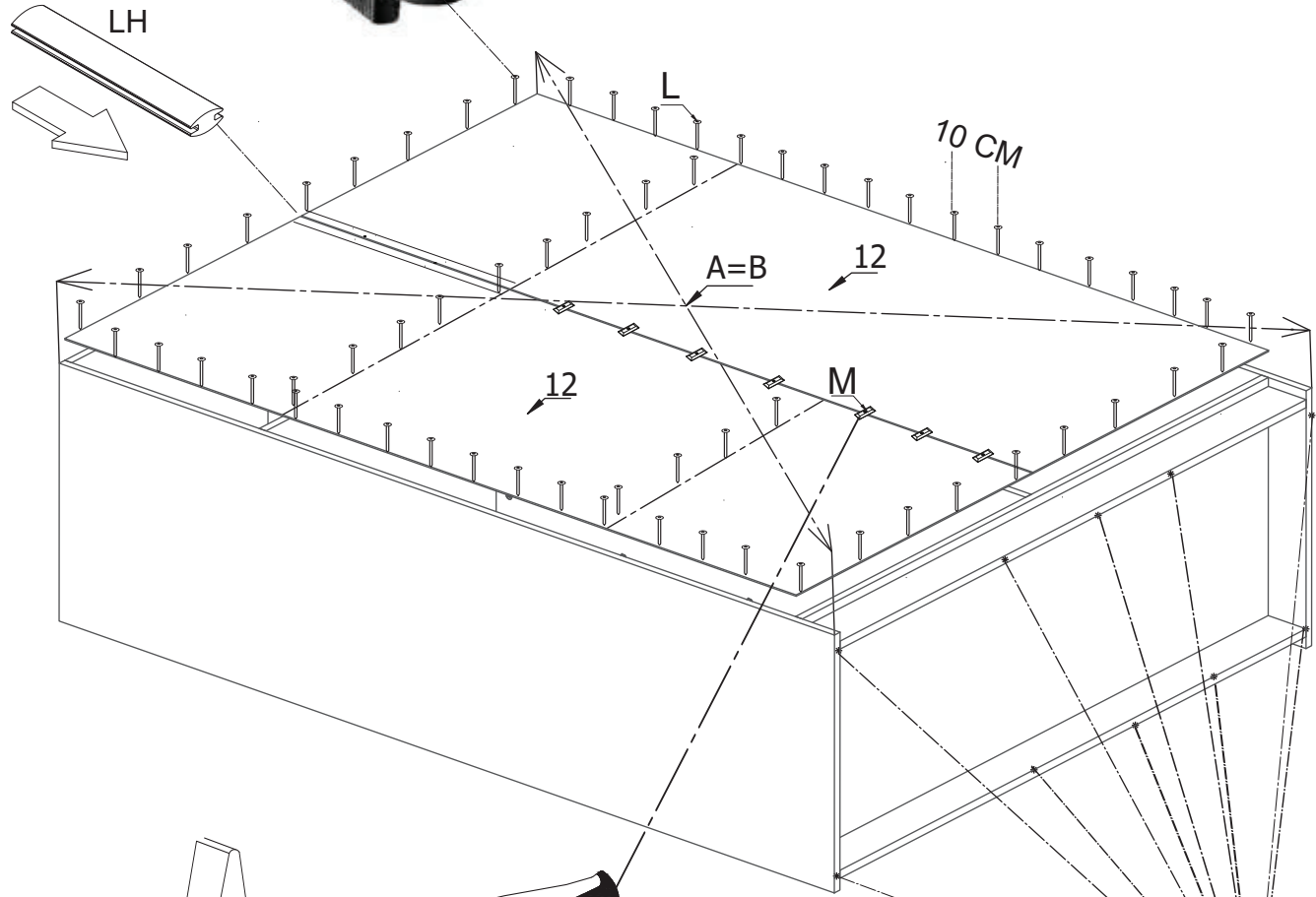
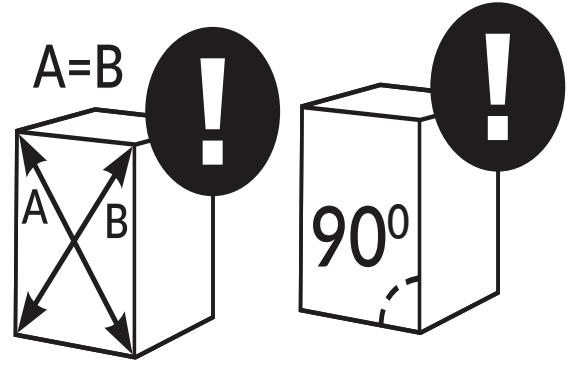
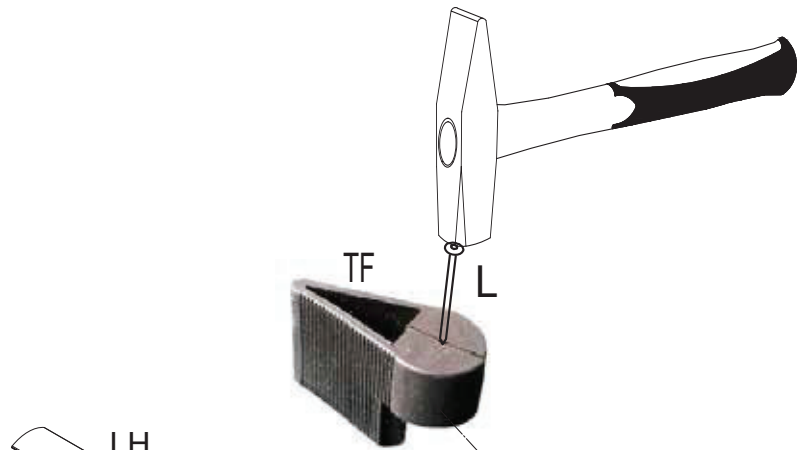
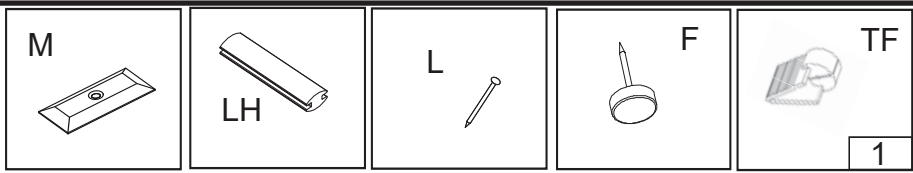

PL  
**WKRETY 1A I 2A DOKRĘCIĆ MAXYMALNIE DO MOMENTU ABY SPRĘŻYNA PRACOWAŁA SWOBODNIE GÓRA/DÓŁ**

GB  
**TIGHTEN SCREWS 1A AND 2A MAXIMUM TO THE TORQUE THAT THE SPRING WORKS FREELY UP/DOWN**

D  
**Ziehen Sie die Schrauben 1A und 2A maximal fest an Ein Moment, in dem der Frühling wirken kann FREI AUF/AB**

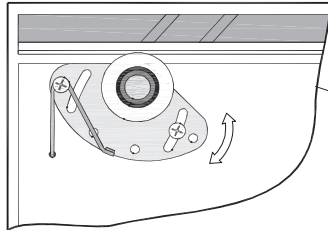
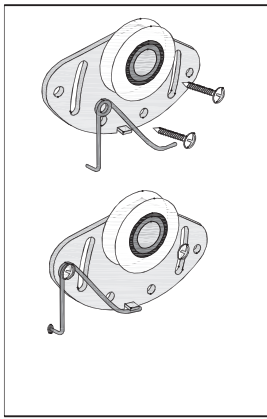
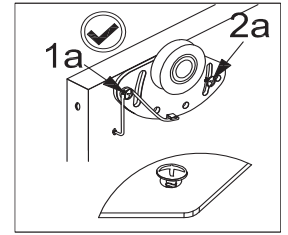
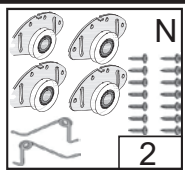

1A 2A

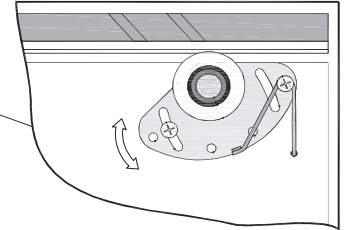

2A 1A

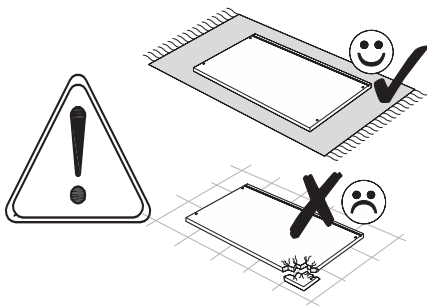

11

x2

1B 2B 3B 4B 5B

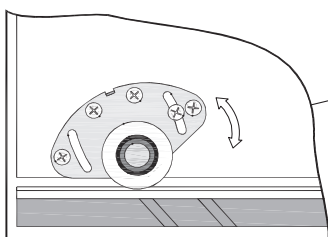

5B 4B 3B 2B 1B

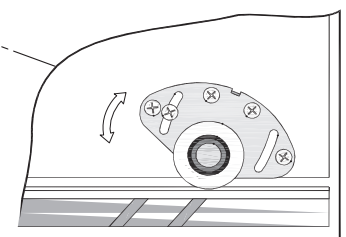

PL  
**JAKO PIERWSZY NALEŻY PRZYKRĘCIĆ WKRĘT 1B, NASTĘPNIE 4B (REGULACJA FRONTU), PO WYREGULOWANIU FRONTÓW NALEŻY PRZYKRĘCIĆ WKRETY 2B, 3B, 5B**

GB  
**FIRST, SCREW 1B SHOULD BE SCREWED IN, THEN 4B (FRONT ADJUSTMENT), AFTER ADJUSTING THE FRONTS, SCREW 2B, 3B, 5B SCREWS SHOULD BE SCREWED IN**

D  
**SCHRAUBE 1B SOLLTE ZUERST GESCHRAUBT WERDEN, DANN 4B (VORDERE EINSTELLUNG), NACH DEM EINSTELLEN DER FRONTEN SOLLTEN DIESE VERSCHRAUBT WERDEN SCHRAUBEN 2B, 3B, 5B**



11

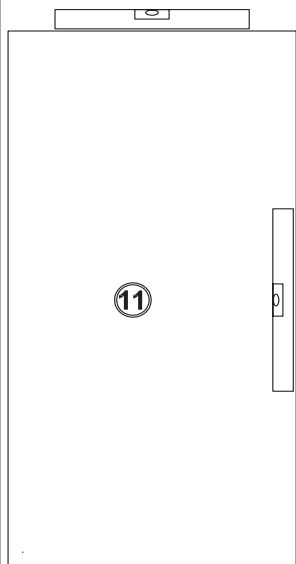

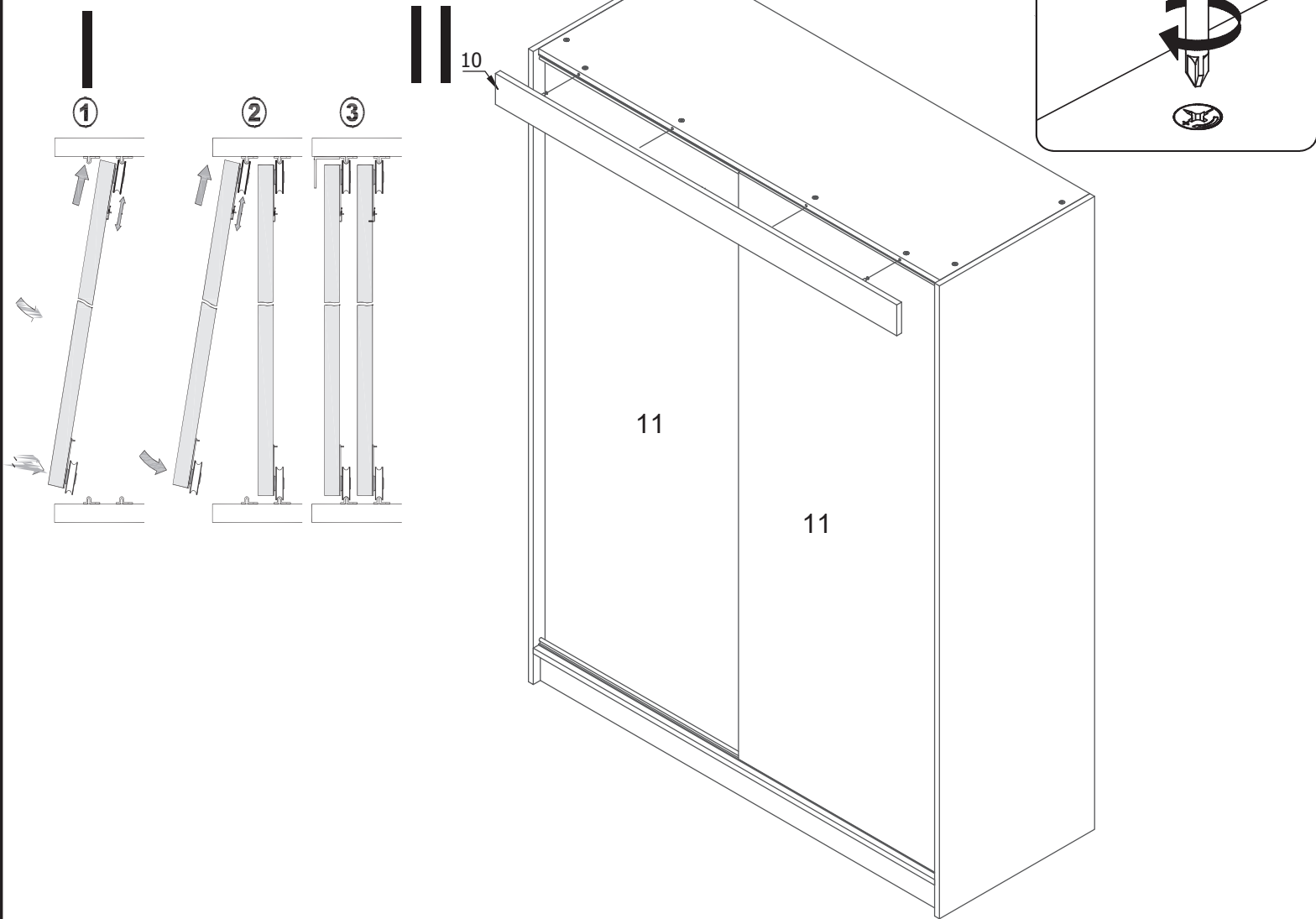

**ZASADY UŻYTKOWANIA I KONSERWACJI MEBLI**  
**GRUNDSÄTZE ZUR MÖBELNUTZUNG UND PFLEGE**  
**GUIDLINES FOR FURNITURE USE AND MAINTENANCE**

**PL**

1. Meble należy użytkować w pomieszczeniach suchych przed szkodliwymi wpływami atmosferycznymi .
2. Montaż mebli należy przeprowadzić zgodnie z instrukcją montażu mebla.
3. miejsce montażu mebla w miarę możliwości powinno odbywać się jak najbliżej miejsca docelowego.
4. meble przy ustawieniu należy wypoziomować
5. Przemieszczanie mebli winno być dokonywane poprzez przenoszenie bez dodatkowego obciążenia. Ciągnięcie przesuwanie mebli grozi trwałym nieodwracalnym uszkodzeniem .Podczas przenoszenia należy chwycić za elementy pionowe. Boki nogi . Nie wolno chwycić za części poziome które mogą być podatne na uszkodzenia tj. blaty szuflady .
6. Nie należy nadmiernie obciążać mebli ,grozi to ich trwałym uszkodzeniem
7. W trakcie użytkowania mebli należy okresowo sprawdzać stan połączeń mimosrodkowych zaisów i przewodników do zawiasów.
8. Powierzchnie należy czyścić tylko środkami do pielęgnacji mebli.

**D**

1. Die möbel sind nur in trockenen räumen unterzubringen wo sie gegen schädliche witterungseinflüssen geschüttyt werden können
2. Die montage von einzelelementen ist gemäß montageanleitung durchzuführen
3. Der montageplatz der möbel sollen die möbelstücke horizontiert werden.
5. Die möbel sind nur ohne zusätzliche belastung zu bewegen beim verschieben und am-boden-ziehen können dauerhafte schäden entstehen bei der bewegung soll immer nur an senkrechten elementen wiez seitenflächen oder beinen gehalten werden .waagrechte bauteile wie platten schubladen, dürfen dabei nicht beansprucht werden weil sie beschädigungsanfälligsein können.
6. Die möbel dürfen nicht übermäßig belastet werden denn eine überbelastung kann dauerhaften schäden verursachen.
7. während der möbelnutzung soll notfalls der zustand der außermittigen verbindungen kontrolliert werden möbeloberflächen sind nurmit speziellen dazu geeigneten möbelpflegemitteln zu reinigen.

**GB**

1. Furniture should be used in rooms which are dry and protected against the harmful influences of weather conditions.
2. Furniture should be assembled in accordance with the assembly manual.
3. Furniture should be assembled as close as possible to it's intended final location.
4. While positioning the furniture make sure it is levelled
5. Furniture may be moved only by lifting and carrying it over when emptied of its contents. Pusching it over or pulling it along may ruin the furniture permanently. While carrying the furniture over it must be held by its vertical elements , i.e side panels or legs. Furniture cannot be held by it's horizontal elements prone to destruction, i.e desktops drawer, etc..
6. furniture should not be overloaded as this may ruin it permanently.
7. While using the furniture ,the state of the connections between it's elements should be checked if necessary.
8. furniture surface must be cleaned only with furniture maintenance formulas.

**Wardrobe 120/150/180**  
Video Assembling Instruction

**Kleiderschrank 120/150/180**  
Video Montageanleitung

**Szafa 120/150/180**  
Video Instrukcja montażu

