

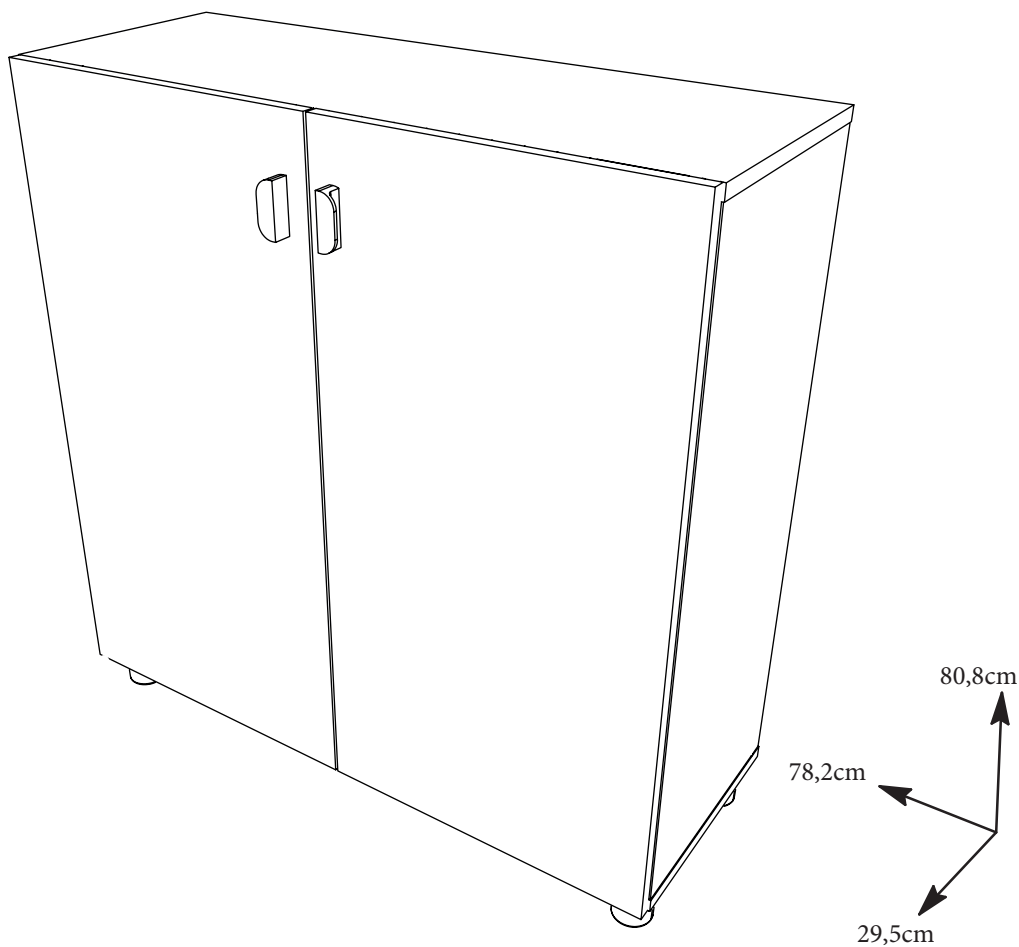

# ENFILADE 2 PORTES

0410EN2P



## FR Remerciements :

Nous vous remercions d'avoir choisi un meuble créé et fabriqué par le Groupe Parisot et espérons qu'il vous donnera entière satisfaction.

## EN Thanks:

Thank you for choosing furniture designed and manufactured by the Parisot Group. We hope you are totally satisfied with your purchase.

## DE Danksagung:

Wir danken Ihnen für den Kauf eines Frankreich von der Parisot-Gruppe entworfenen und hergestellten Möbelstücks und hoffen, dass Sie es zu Ihrer vollkommenen Zufriedenheit finden werden.

## HU Köszönet:

Köszönjük, hogy a Parisot Groupe által létrehozott és gyártott bútort választott, reméljük, hogy elégedett lesz a termékkel.

## PT Agradecimentos:

Obrigado por ter escolhido um móvel concebido e fabricado pelo Grupo Parisot, esperando que seja do seu inteiro agrado.

## IT Ringraziamenti:

Grazie per avere scelto un mobile progettato e fabbricato dal Gruppo Parisot. Speriamo soddisfatti appieno le vostre esigenze.

## NL Bedankje:

Wij bedanken u voor de aankoop van een door de Groep Parisot ontworpen en vervaardigd meubel en hopen dat u er veel plezier aan zult beleven.

## CZ Poděkování:

Děkujeme, že jste si vybrali nábytek navržený a vyrobený společností Parisot Group. Doufáme, že budete svým nákupem naprosto spokojeni.

## ES Agradecimientos:

Les damos las gracias por haber elegido un mueble diseñado y fabricado por el Groupe Parisot y esperamos que sea de su total agrado.

## PL Podziękowania:

Dziękujemy za wybór mebli stworzonych i wyprodukowanych przez Grupę Parisot. Mamy nadzieję, że będziecie Państwo w pełni zadowoleni z zakupu.

## SK Pod'akovanie:

Ďakujeme, že ste si vybrali nábytok navrhnutý a vyrobený spoločnosťou Parisot Group. Dúfame, že budete svojím nákupom absolútne spokojní.

## AR شكر:

نشكركم لاختياركم هذه القطعة من الأثاث من تصميم وتصنيع مجموعة باريسو Parisot ونتمنى أن تتال رضائكم.



1h15

## PARISOT INDUSTRIE

15 Avenue Jacques Parisot, 70800 Saint-Loup sur Semouse  
RCS VESOUL 537 665 200 contact@parisot.com

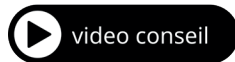

## Matériel nécessaire

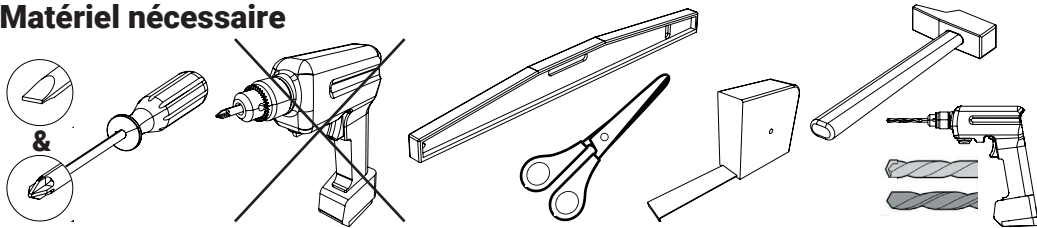

## Conseils d'entretien

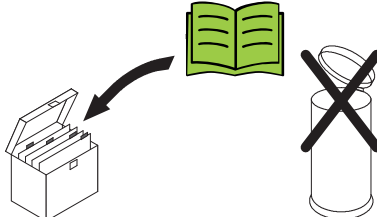

Repérer vos pièces

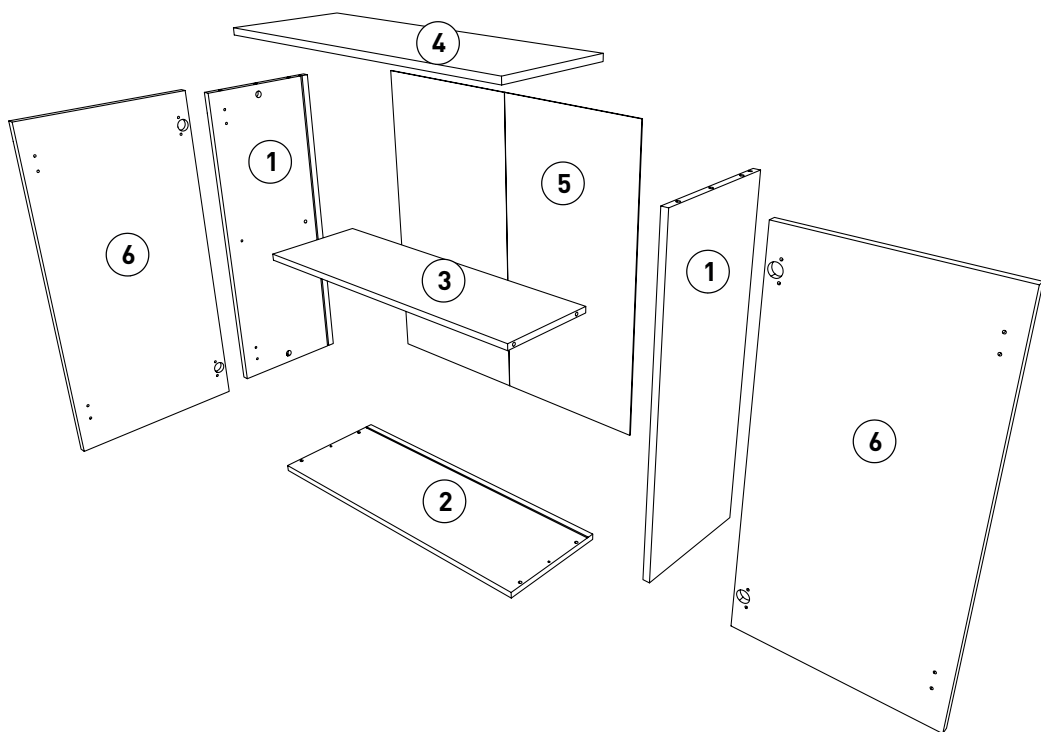





		cm		
Rep	Qté	Longueur	Largeur	Epaisseur
01	2	72,7	27,9	1,5
02	1	78,2	28	1,5
03	1	75	24	1,5
04	1	78,2	28	1,5
05	1	74,2	76,4	0,25
06	2	75,7	38,7	1,5

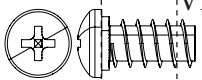
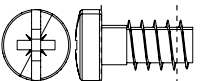
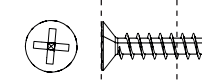
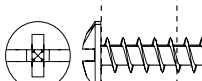
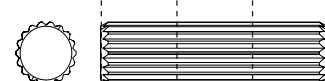

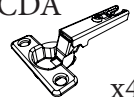
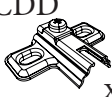
0 1cm 2 3 4 5 6

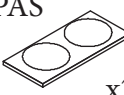
	VB	x1
	CDS	x16
	WJ	x12
	ANE	x4
	ADM	x10

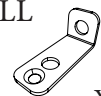
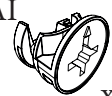
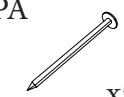
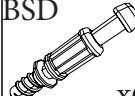
	CDA	x4		CDD	x4
	EP	x4		PAS	x2
	PB	x2		CIS	x4
	BLL	x1		AI	x6
				PA	x5
				BSD	x6

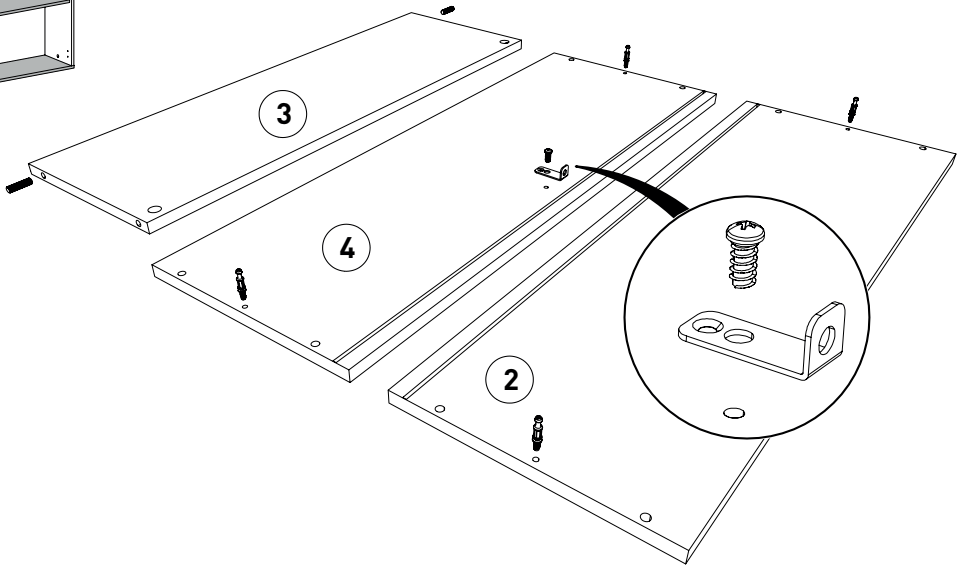
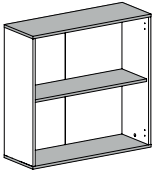
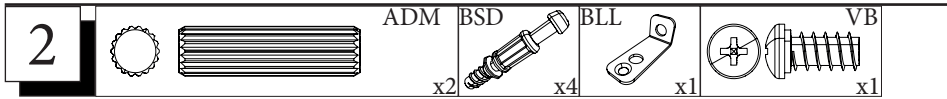
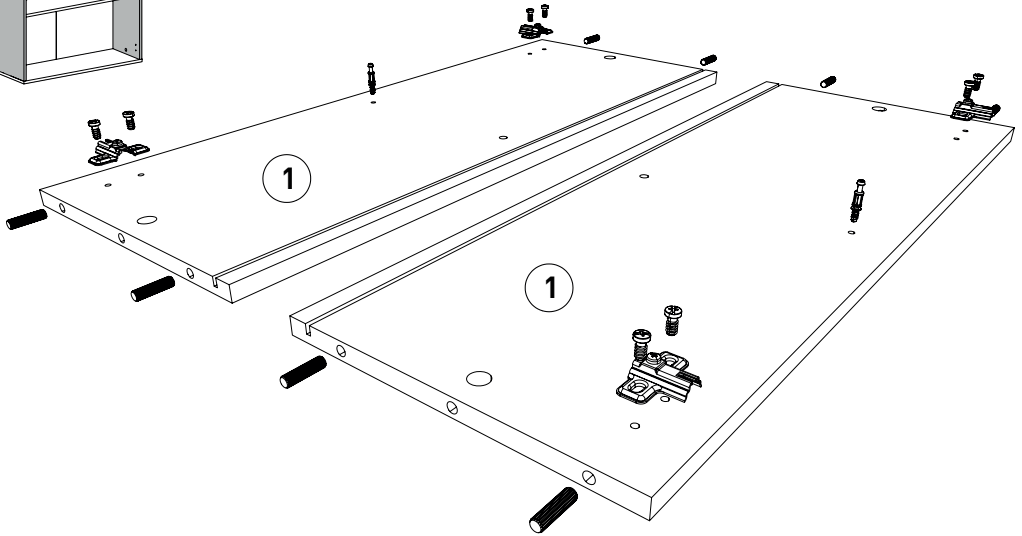
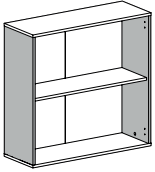
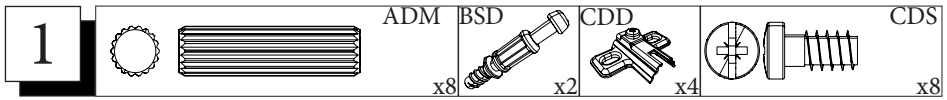

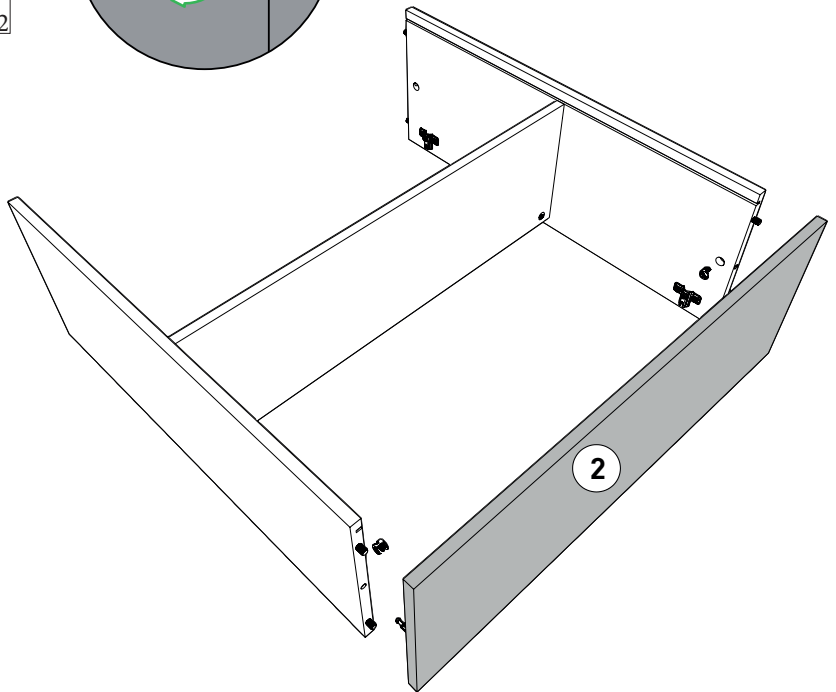
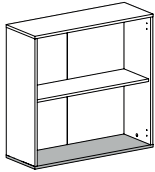
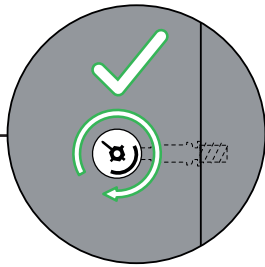
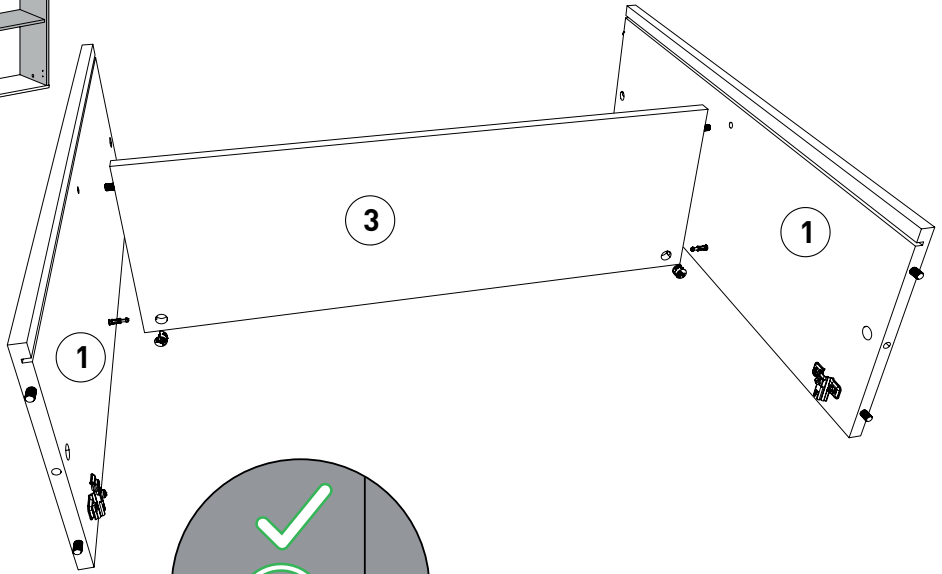
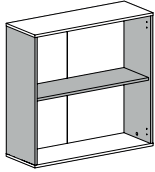

5

CIS



x4



WJ

x12

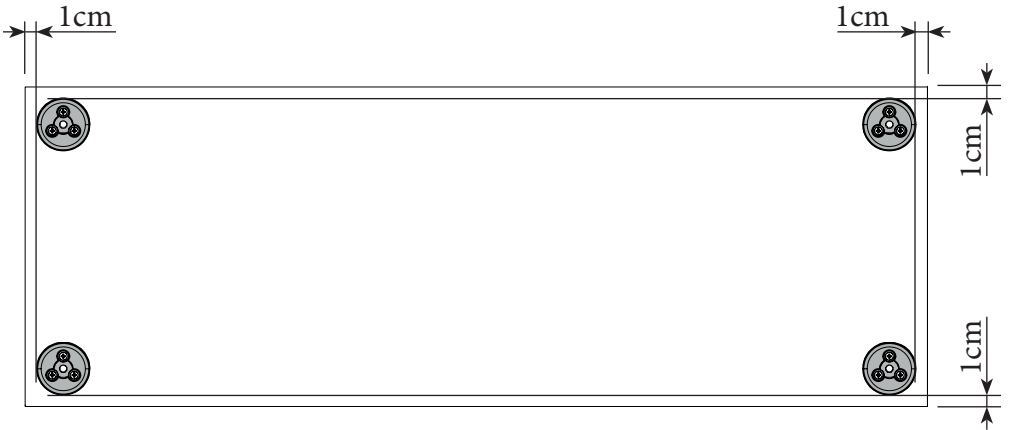
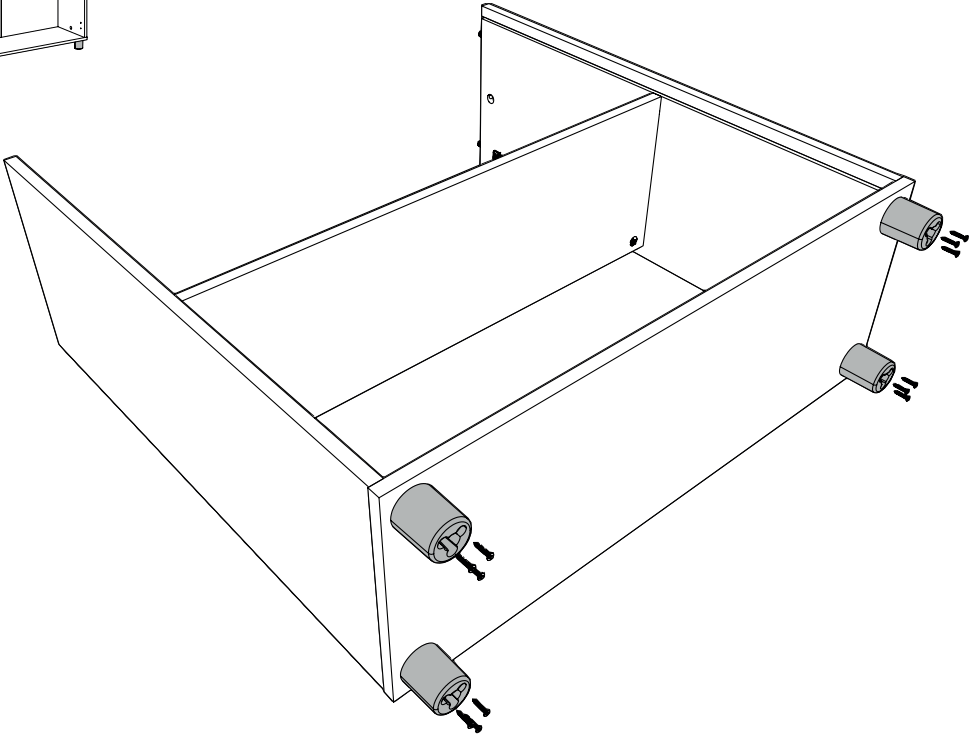
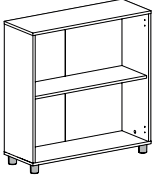

6

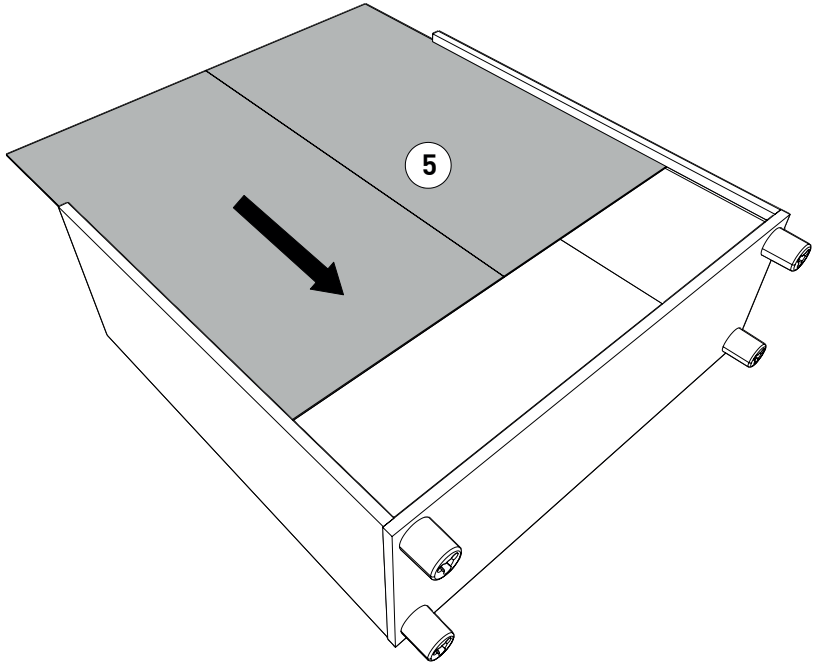
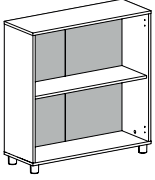

7

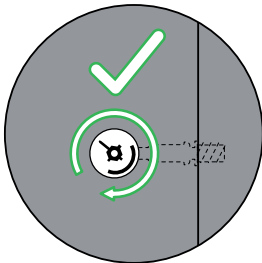
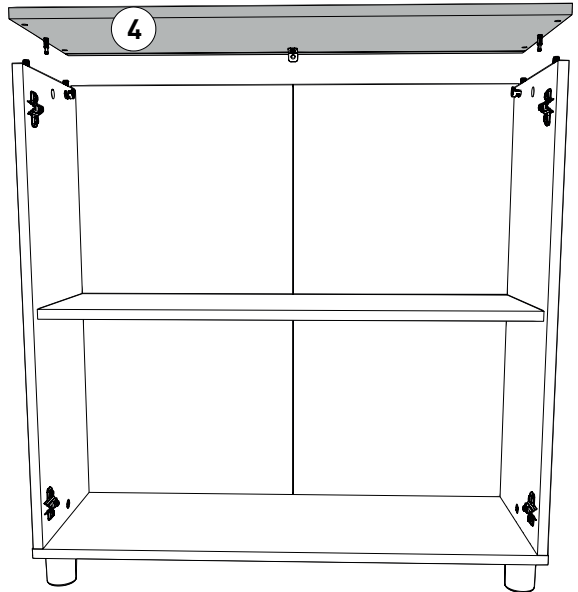
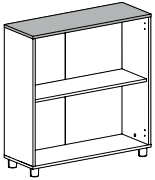
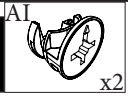

**8**

PA



x5

EP



x4

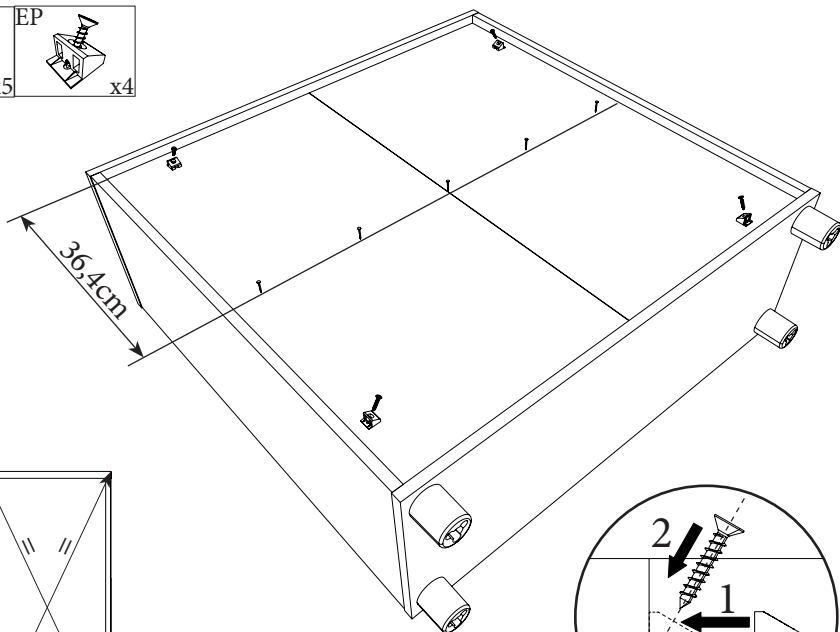
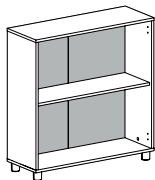

Mesurer les diagonales du meuble pour vérifier l'équerrage. La cote doit être identique

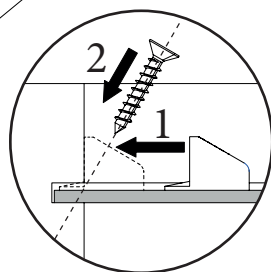
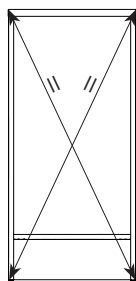
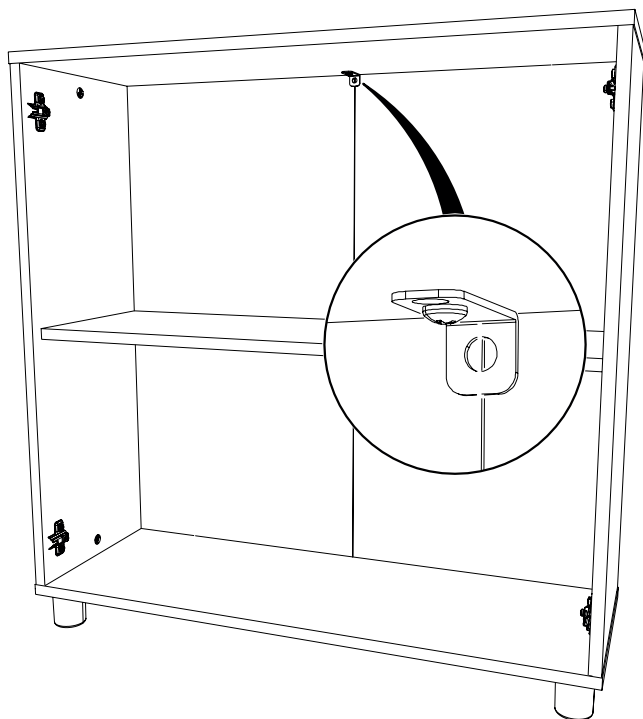
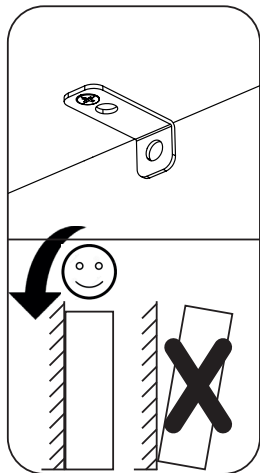
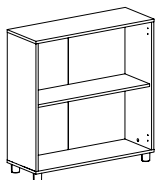
**9**

- FR Pour votre sécurité : Fixation du meuble au mur  
Attention, la fixation doit être réalisée par une personne compétente car cela nécessite des chevilles adaptées à la nature de votre mur.
- EN For your safety: the unit should be secured to the wall.  
NB this should be carried out by a competent person as you must use the right rawlplug for your type of wall.
- DE Zu Ihrer Sicherheit: Befestigen Sie das Hochbett an der Wand.  
Achtung: Diese Befestigung ist durch eine fachlich kompetente Person vorzunehmen. Hierfür sind für die Bauweise Ihrer Wand geeignete Dübel einzusetzen.
- ES Por su seguridad: Fijar el mueble a la pared.  
Advertencia: la fijación la ha de llevar a cabo por personal adecuado, ya que requiere el uso de tacos que se adapten al tipo de pared.
- PT Para sua segurança: fixação do móvel ao muro  
Atenção: a fixação deverá ser efetuada por pessoa habilitada, visto que são necessárias cavilhas adaptadas ao tipo de parede.
- IT Avvertenza di sicurezza: il fissaggio del mobile a parete deve essere realizzato da una persona competente, in quanto l'operazione richiede l'impiego di tasselli adatti alla natura del muro.
- NL Voor uw veiligheid: bevestiging van het meubel aan de muur.  
Opgelet de bevestiging moet worden uitgevoerd door een bekwaam persoon daar dit voor uw type muur geschikte pluggen vereist.
- CZ Z bezpečnostních důvodů: upevněte nábytek do zdi  
Pozor, upevnění je třeba svěřit kompetentní osobě, neboť vyžaduje hmoždinky vhodné pro vaši zeď.
- HU Az Ön biztonsága érdekében : a bútor falra rögzítése  
Figyelmeztetés : a rögzítés csak megfelelő szakképesítéssel rendelkező személy által végezhető el, mert a rögzítéshez a falnak megfelelő csavarokra van szükség.
- PL Dla bezpieczeństwa: mocowanie mebla do ściany  
Uwaga, mocowanie musi zostać wykonane przez osobę kompetentną, ponieważ wymaga to zastosowania kołków dostosowanych do rodzaju ściany.
- RO Pentru securitatea dumneavoastră: fixarea mobilierului de perete  
Atenție, fixarea trebuie să fie realizată de o persoană calificată, deoarece sunt necesare dispozitive de fixare adaptate caracteristicilor peretelui dumneavoastră
- RU Для вашей безопасности: Крепление мебели к стене  
Внимание! Крепление должно производиться опытным специалистом, т.к. для такой установки потребуются штифты, соответствующие типу вашей стены.
- SK Z bezpečnostných dôvodov: nábytok upevnite k stene.  
Dbajte na to, aby upevnenie vykonala kompetentná osoba, pretože pri upevňovaní sa vyžadujú kolíky vhodné do materiálu, z ktorého je stena vyrobená.
- TR Güvenliğiniz için: Mobilyanın duvara sabitlemesi  
Dikkat, sabitleme işlemleri uzman biri tarafından yapılmalıdır çünkü bu işlem için duvarınızın malzemesine uygun dübellerin kullanılması gerekmektedir

### ةيبرعلاة

ةي صخشلا كتمال سل : طئ اءلا لىل ع ءا ءا ل ءة عطق ءي ءب ء  
ان يفسا بل طءءء ان ا ذل طئ اءلا لىل ع ءي ءب ءءلا ءي لم ع ب ص ص ءءم ص ص ءء  
سفن طئ اءلا ءع يبط عم قفاو ءي ان ي عم .

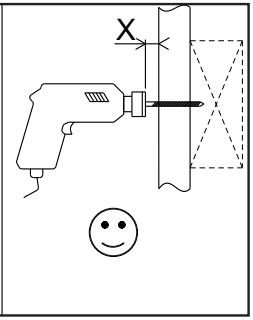
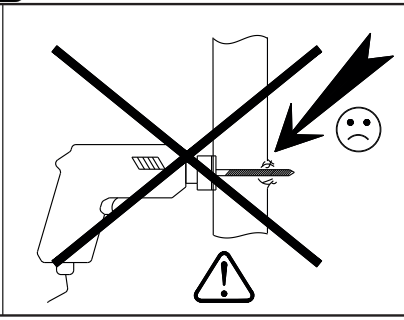
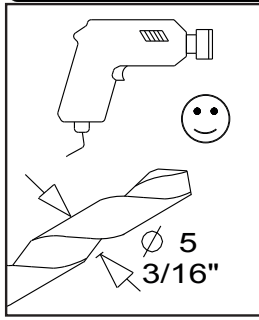
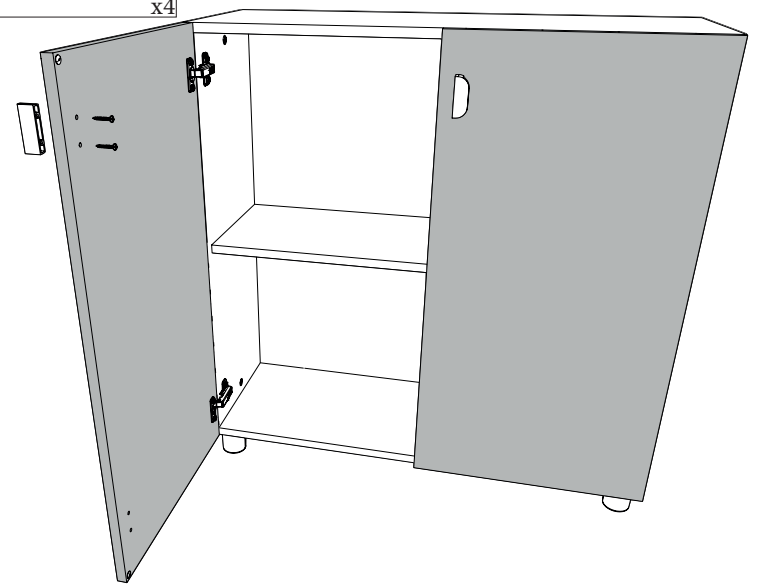
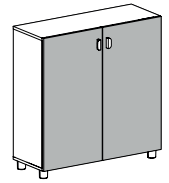
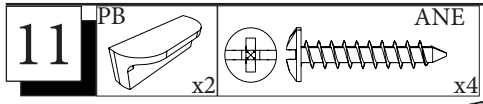
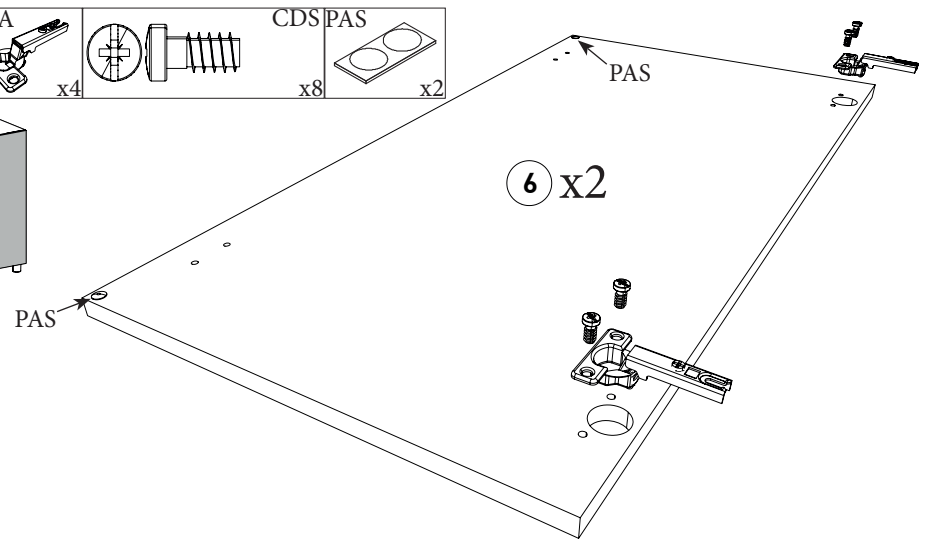
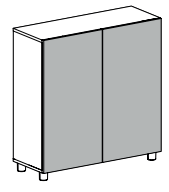
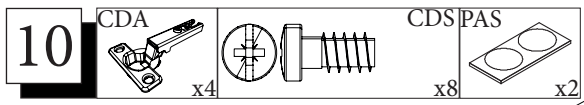

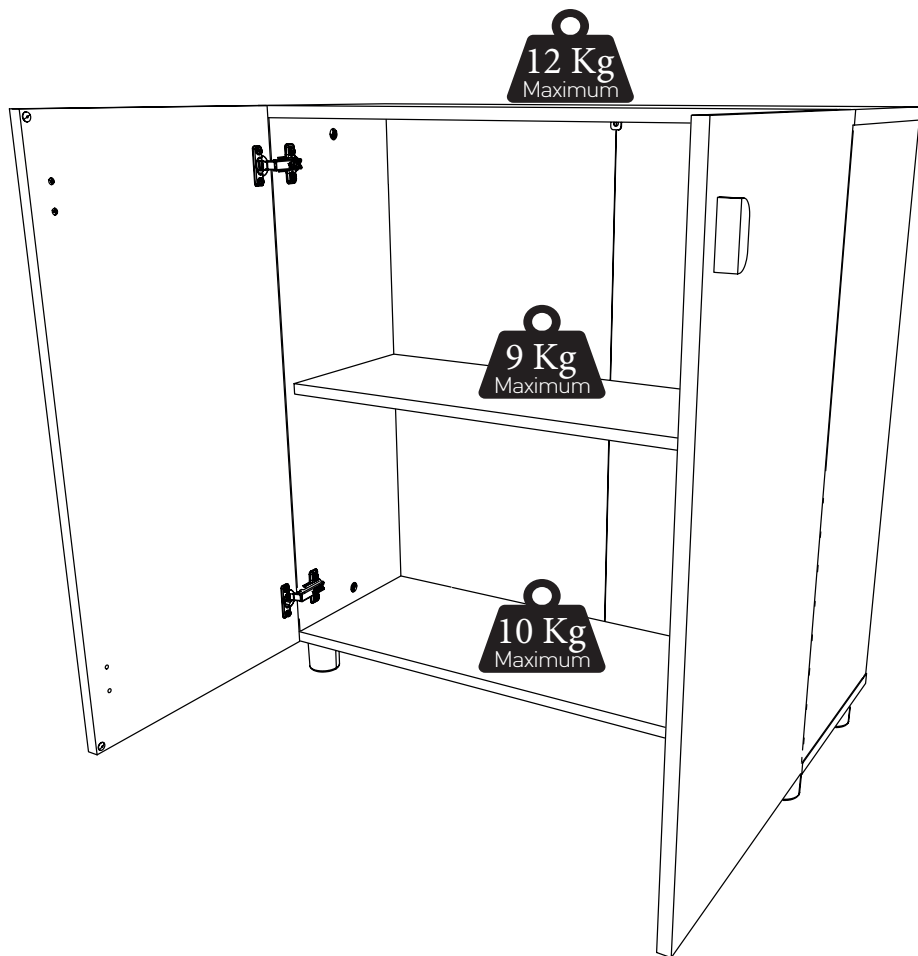

**LE TRI**  
**+ FACILE**



FR

**Pensez à  
donner ou recycler.**



Association

OU



Magasin

OU



Déchèterie

<https://quefairedemesdechets.fr>