

# NEW YORK UPHOLSTERED BED

**Do not discard the packaging until you have successfully completed the assembly.**

Please check that you have all the parts list before you start assembling, if you find that something is missing, do not continue assembly, please contact us immediately.

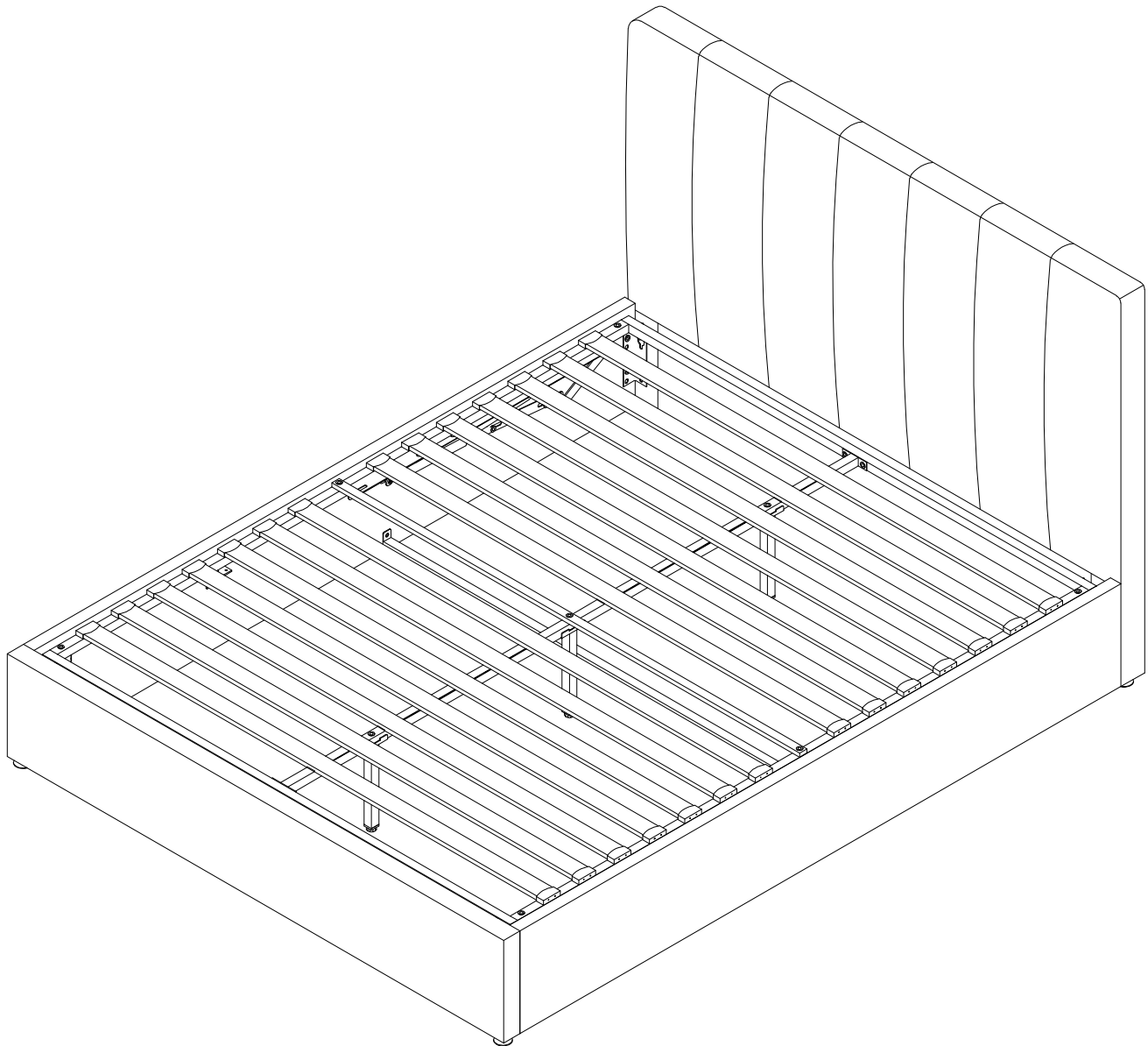

DEAR CUSTOMER,







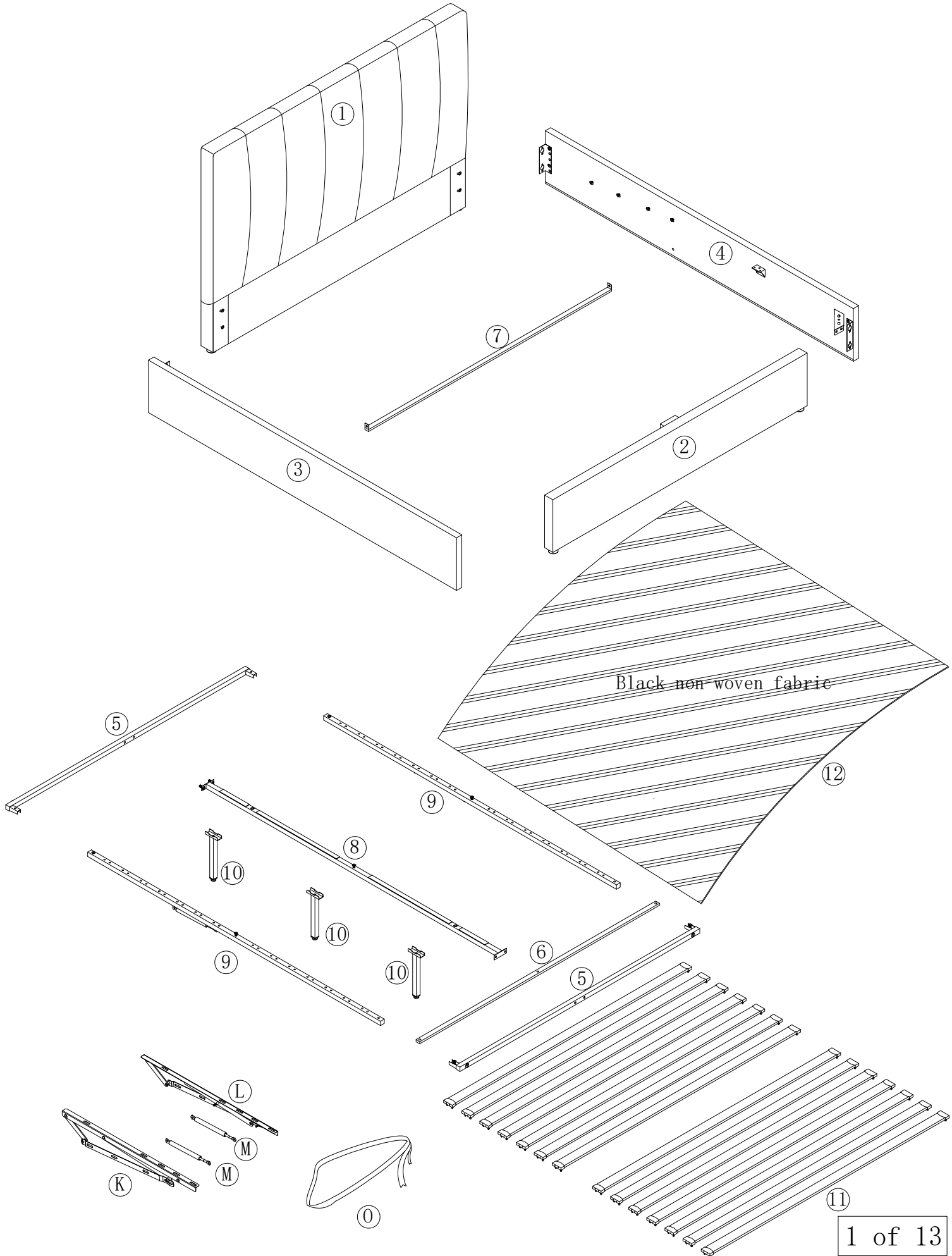

Thank you for choosing our product. Please read this manual carefully before assembling or using the product, to avoid damage caused by improper use. If the product is passed on to third parties, this manual has to be passed on along with the product. For any question don't hesitate to contact us.

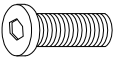
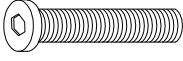
NOTE: Please do not completely tighten all the hardware until the entire assembly is complete!

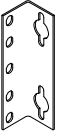
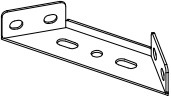
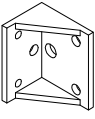
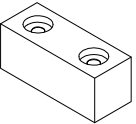
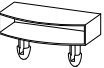
# Part list

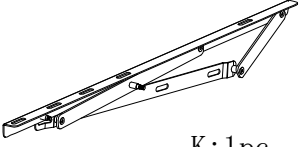
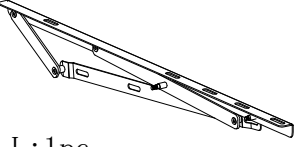
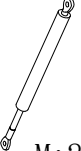

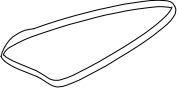
# Assembly Instruction

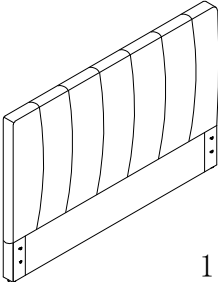
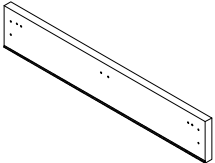
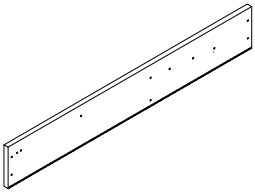
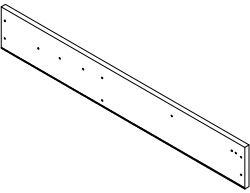
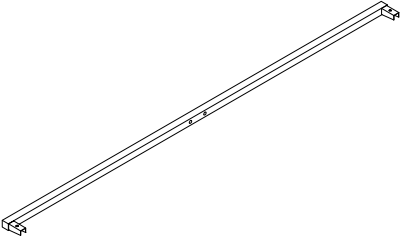
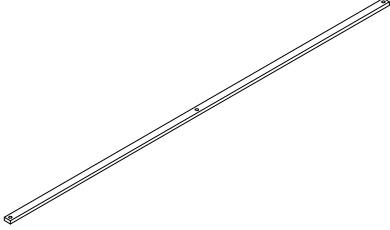
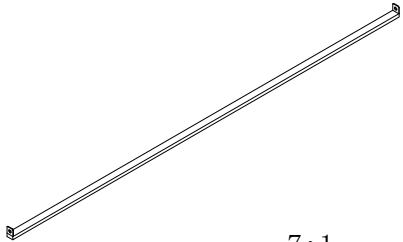
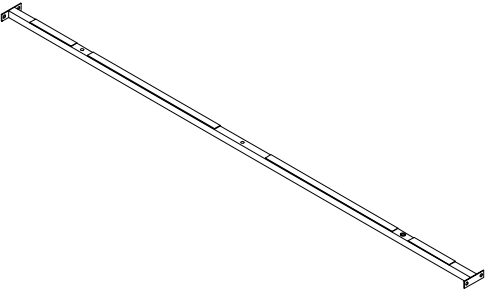
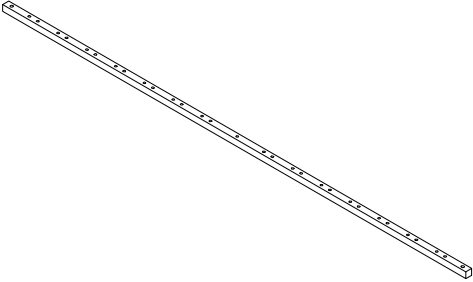
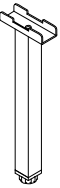
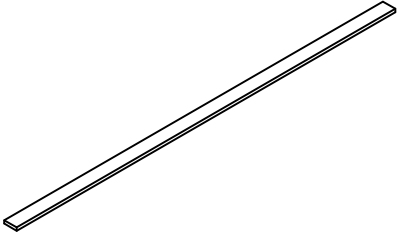
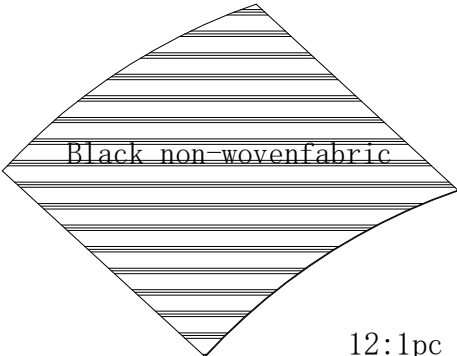
 M8x25 A: 52pcs	 M8x45 B: 5pcs	 C: 4pcs	 D: 4pcs	 E: 2pcs	 F: 2pcs	 G: 1pc	 H: 28pcs
 J: 1pc	 K: 1pc	 L: 1pc	 M: 2pcs	 N: 4pcs	 O: 1pc	 P: 1pc	
 1: 1pc	 2: 1pc	 3: 1pc	 4: 1pc				
 5: 2pcs	 6: 1pc	 7: 1pc					
 8: 1pc	 9: 2pcs	 10: 3pcs					
 11: 14pcs	 Black non-woven fabric 12: 1pc						

# STEP 1

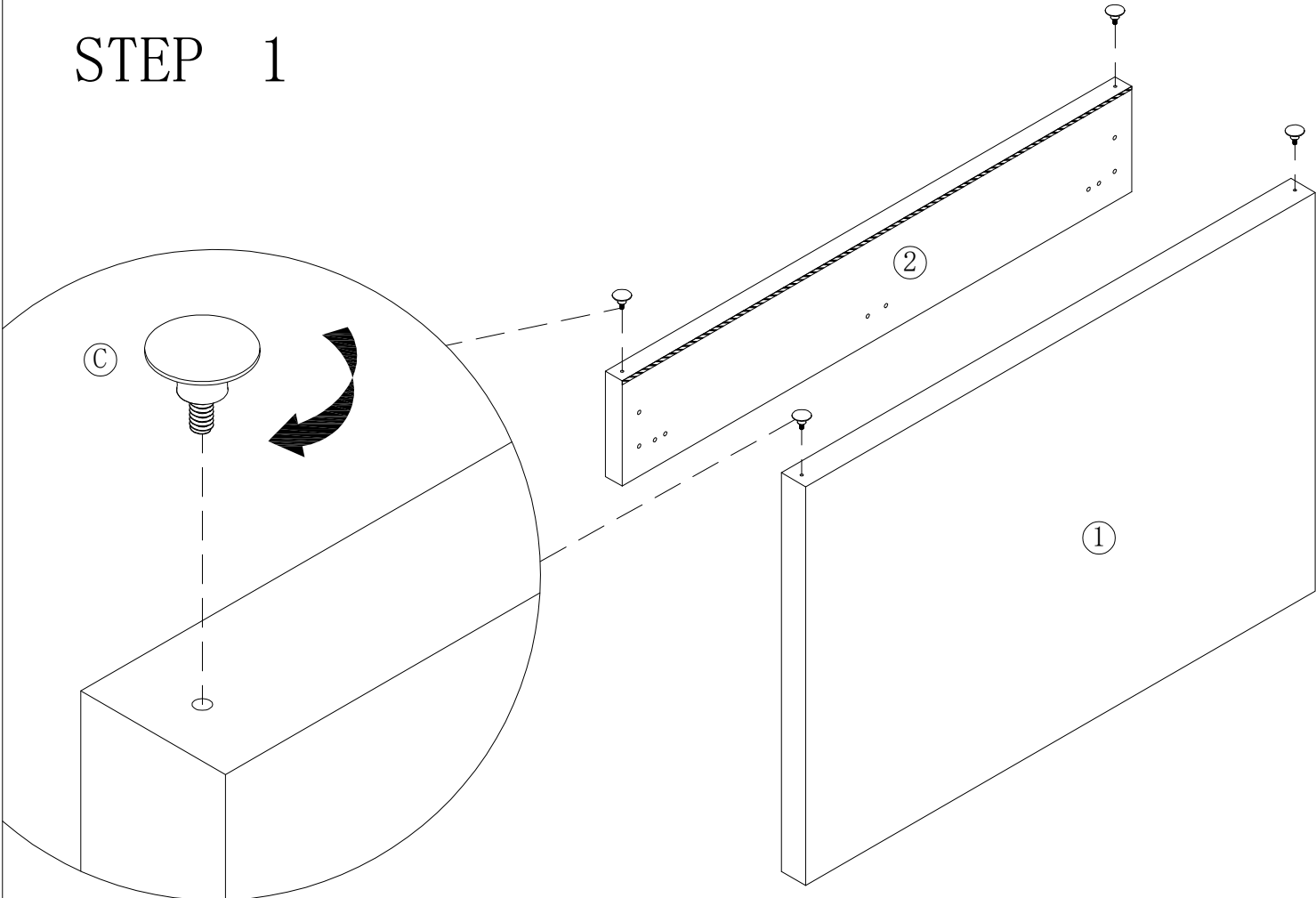

# STEP 2

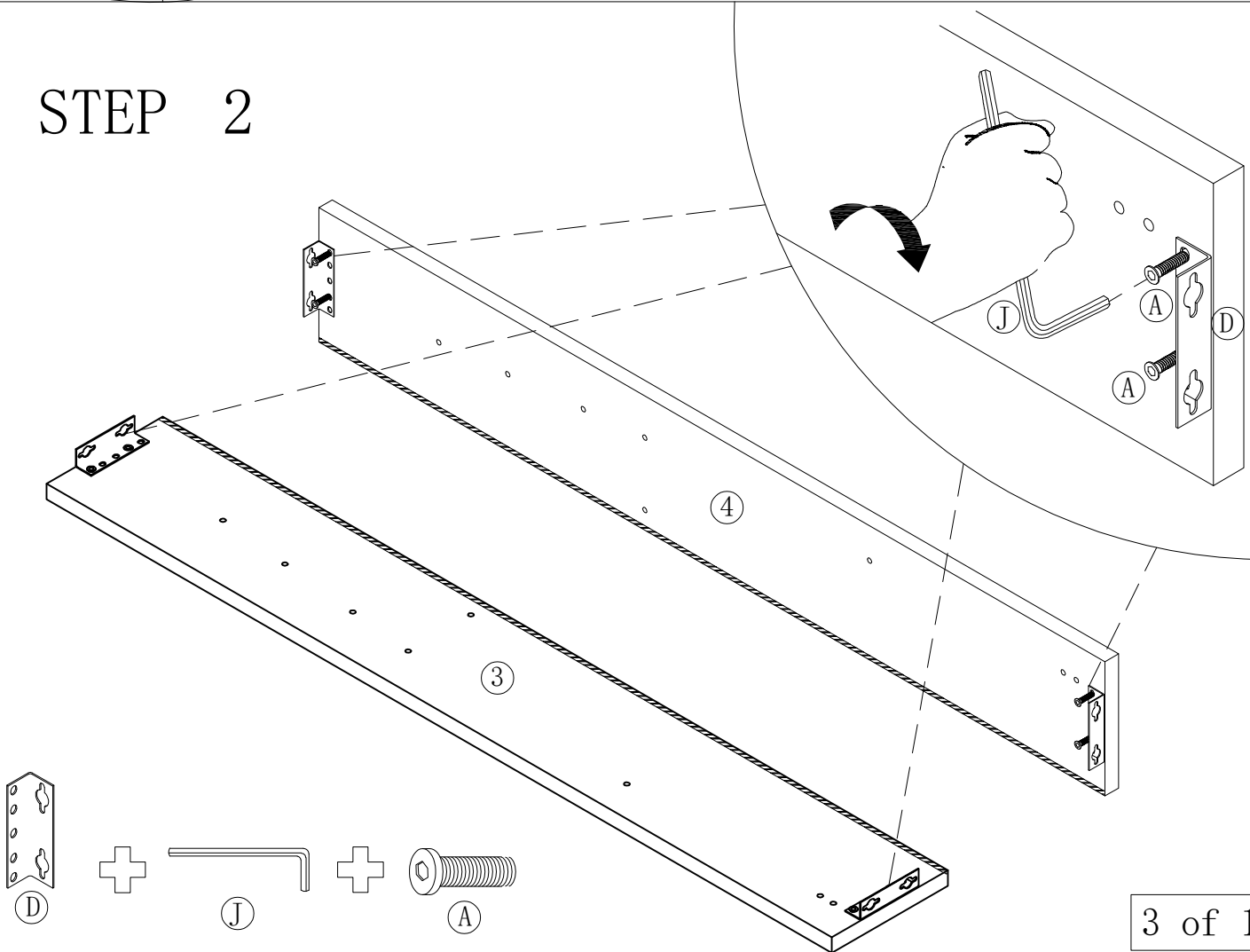

# STEP 3

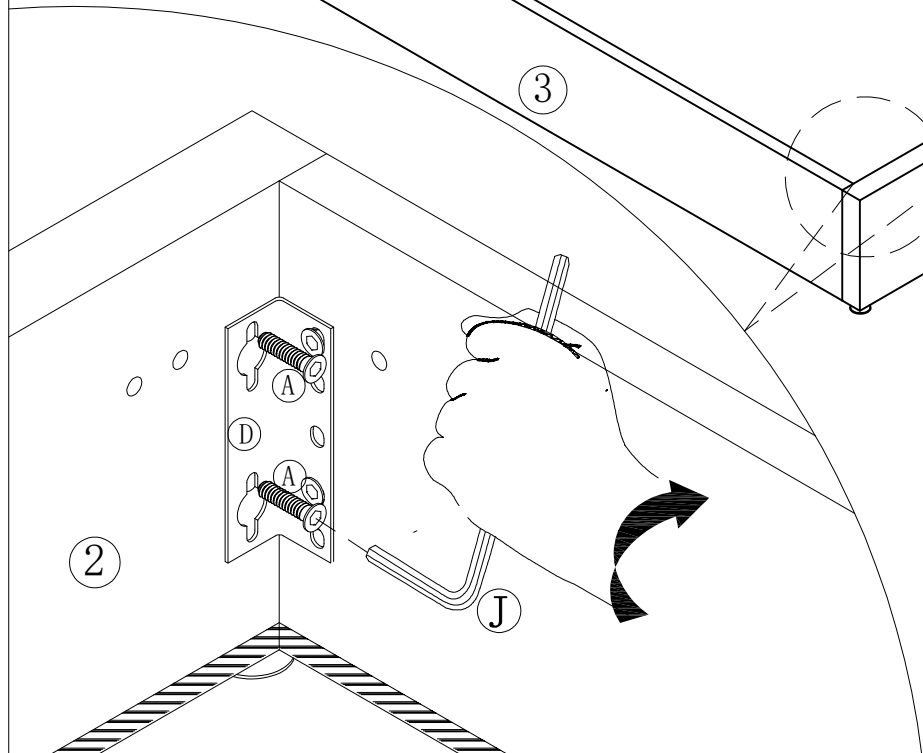
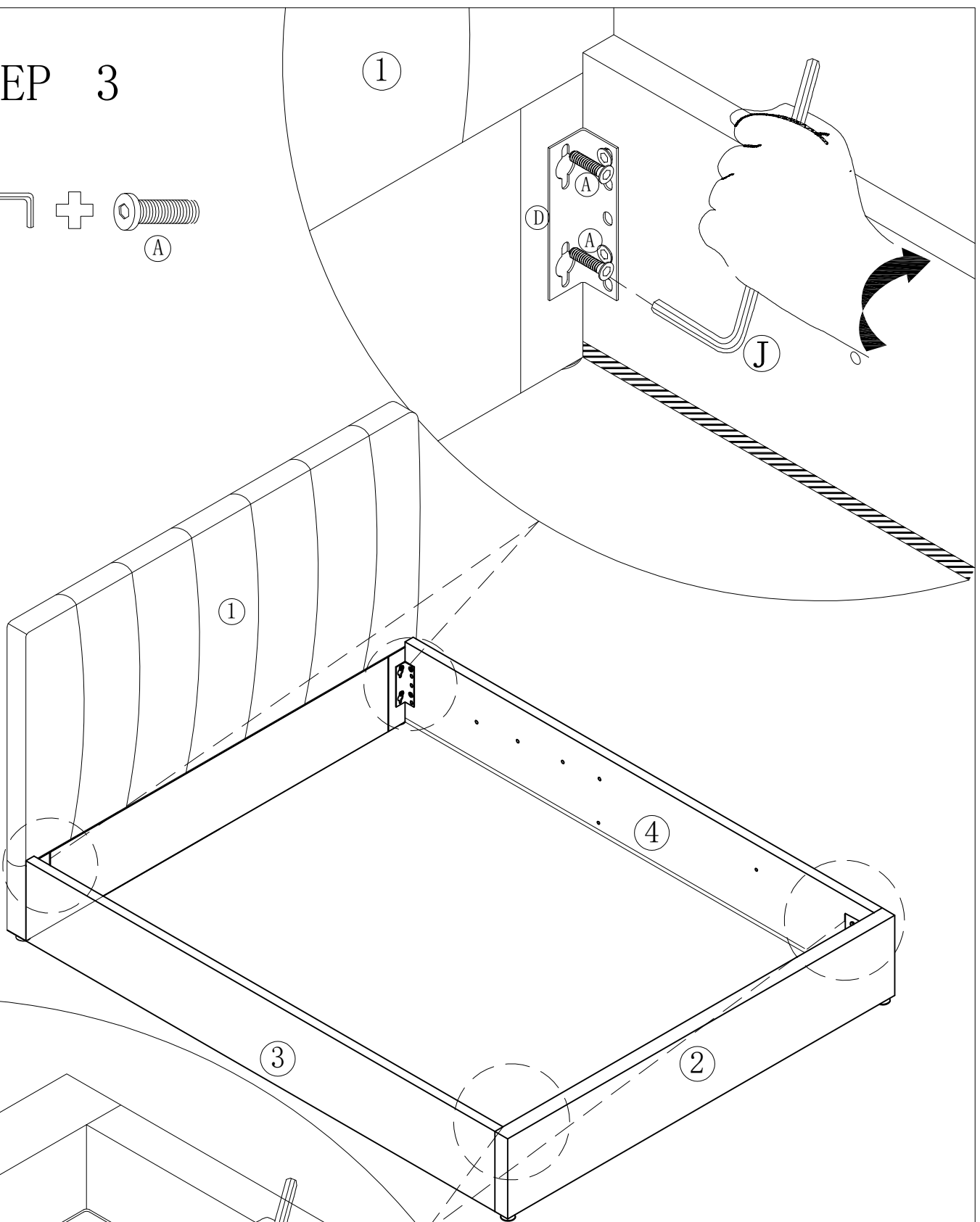
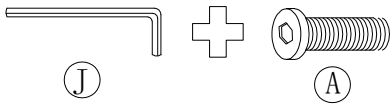

# STEP 4

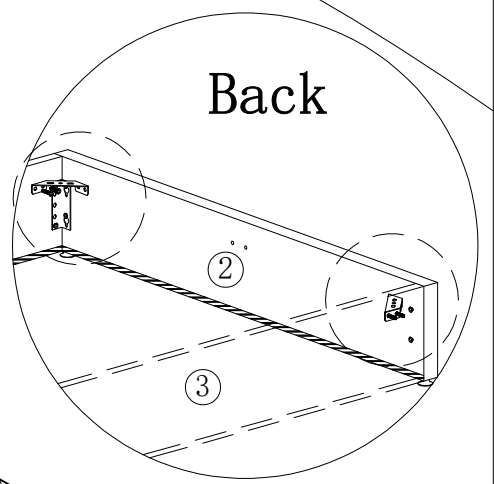
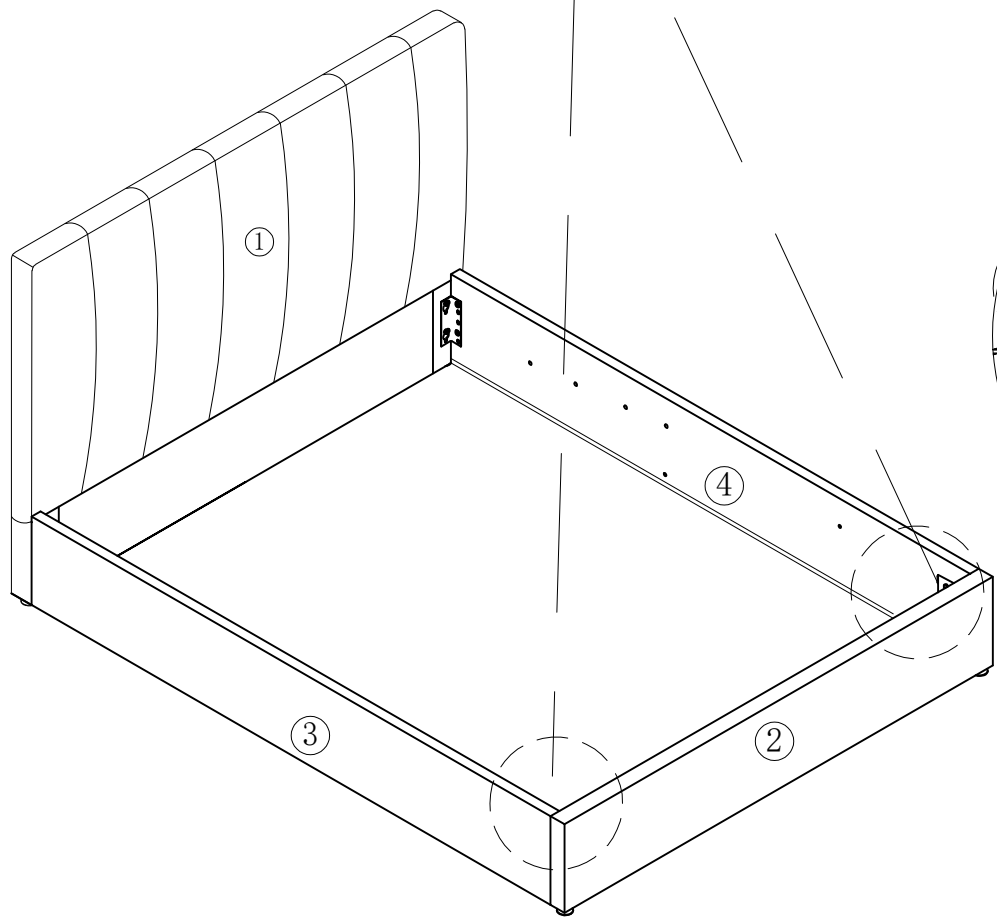
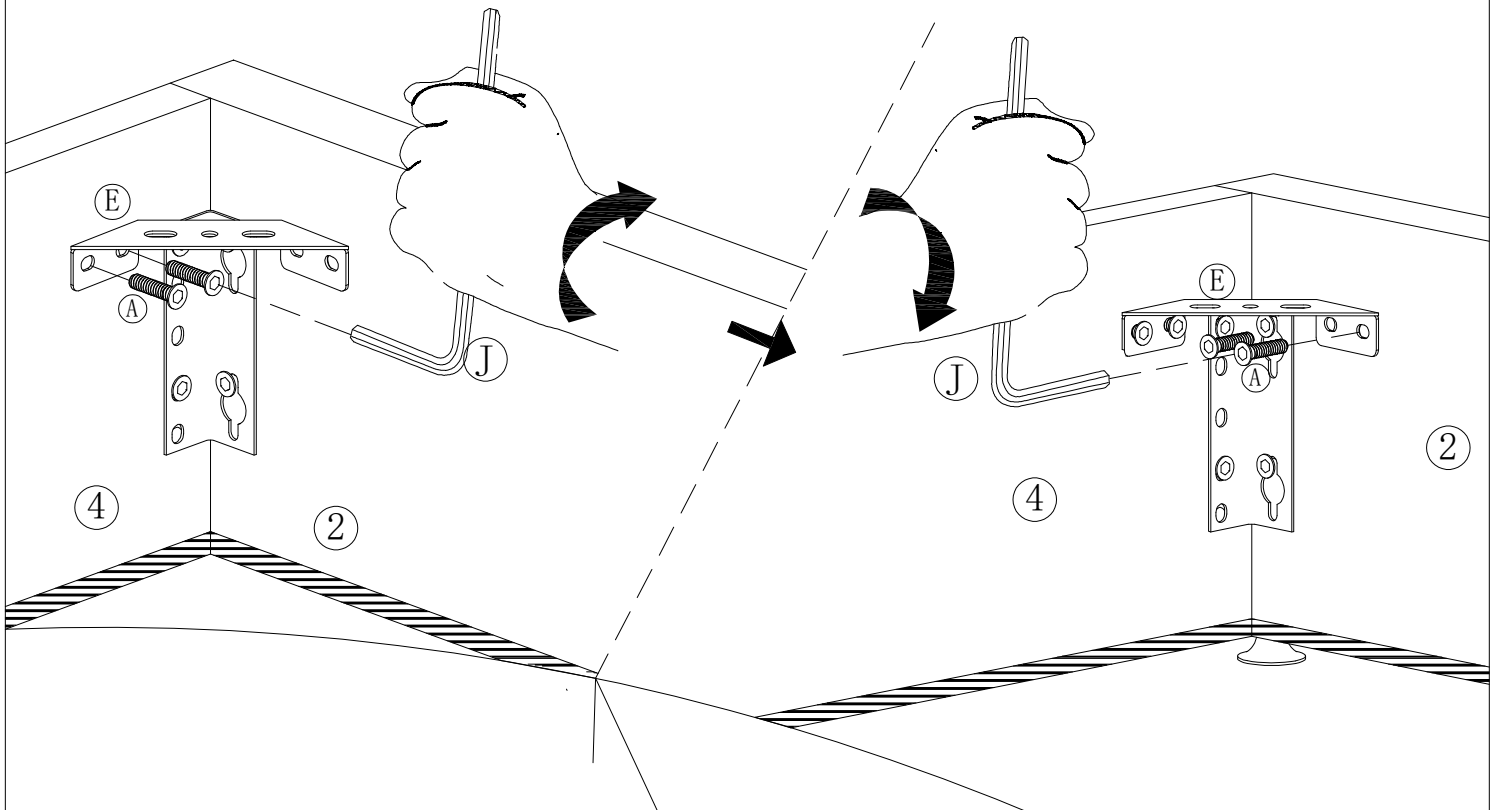
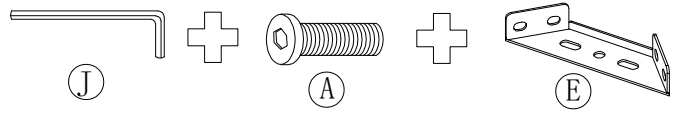

# STEP 5

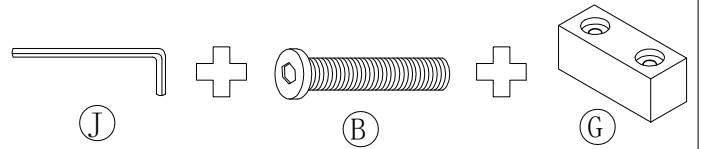
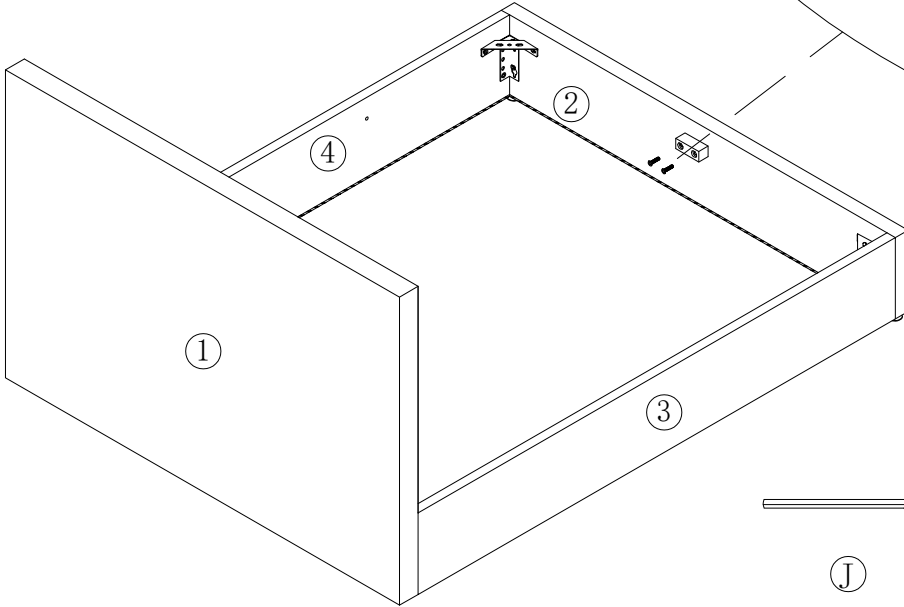
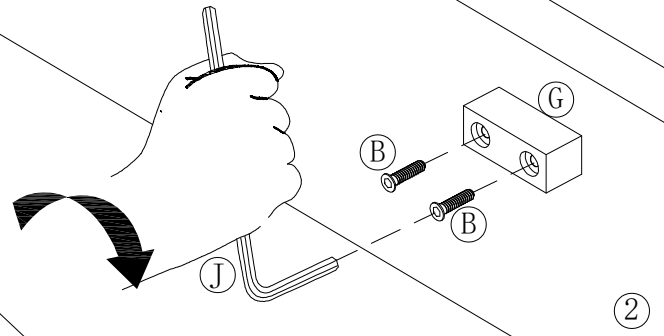

# STEP 6

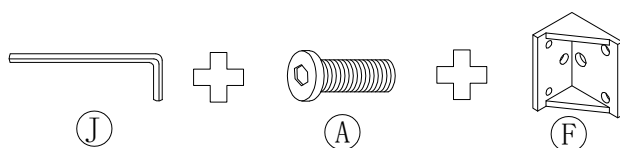
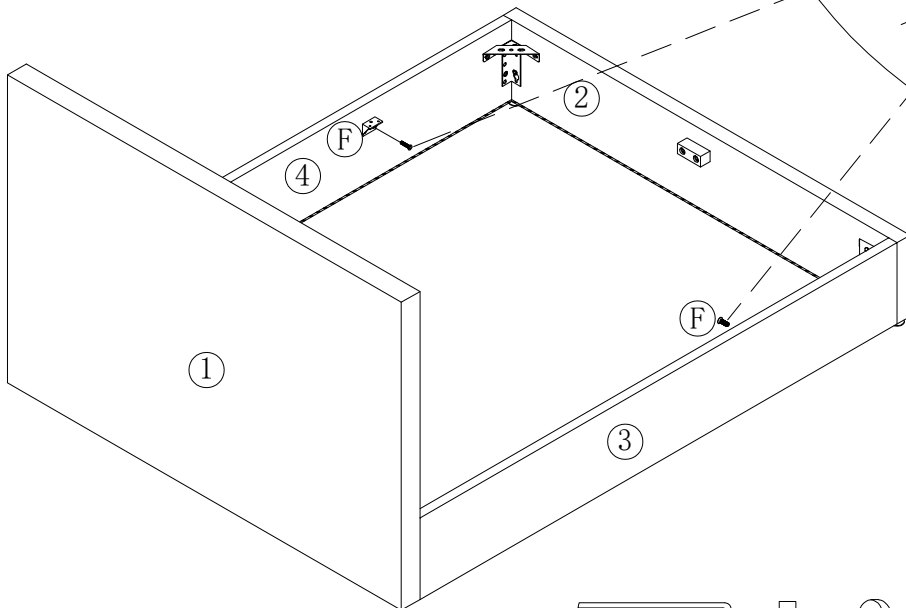
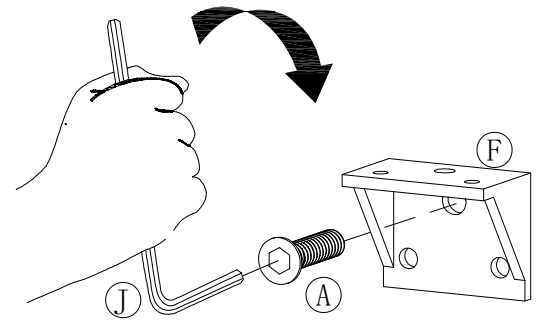

# STEP 7

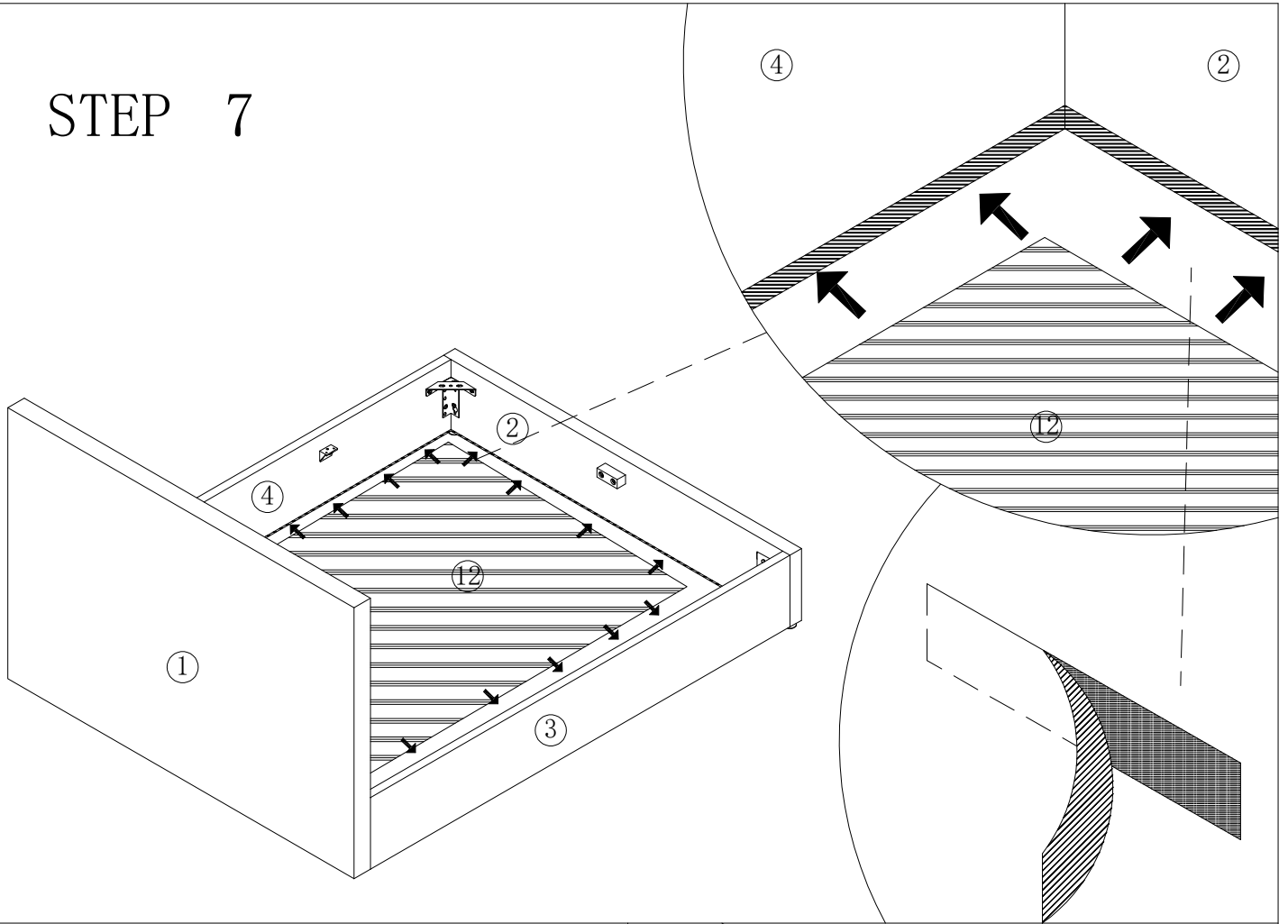

# STEP 8

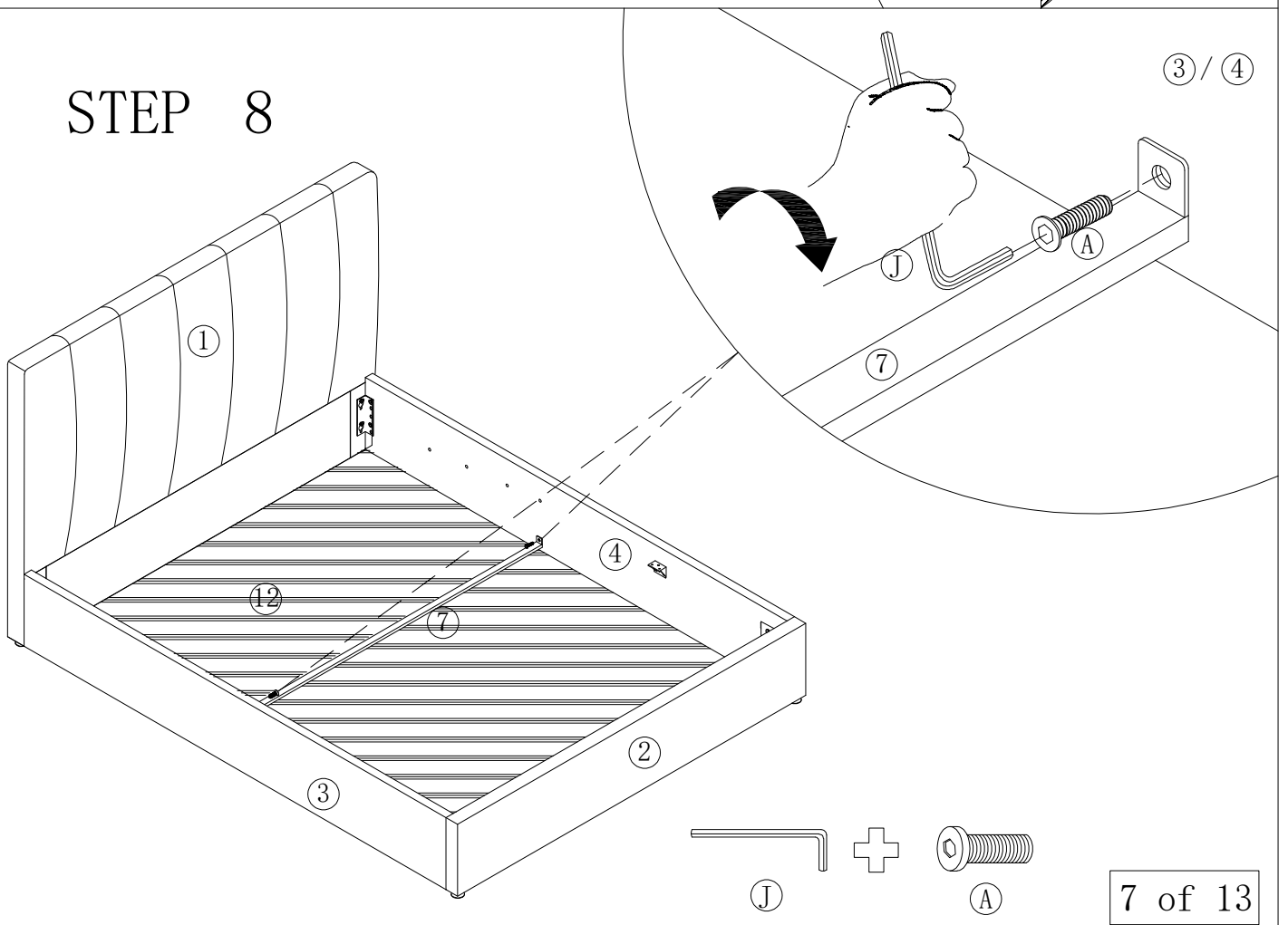

# STEP 9

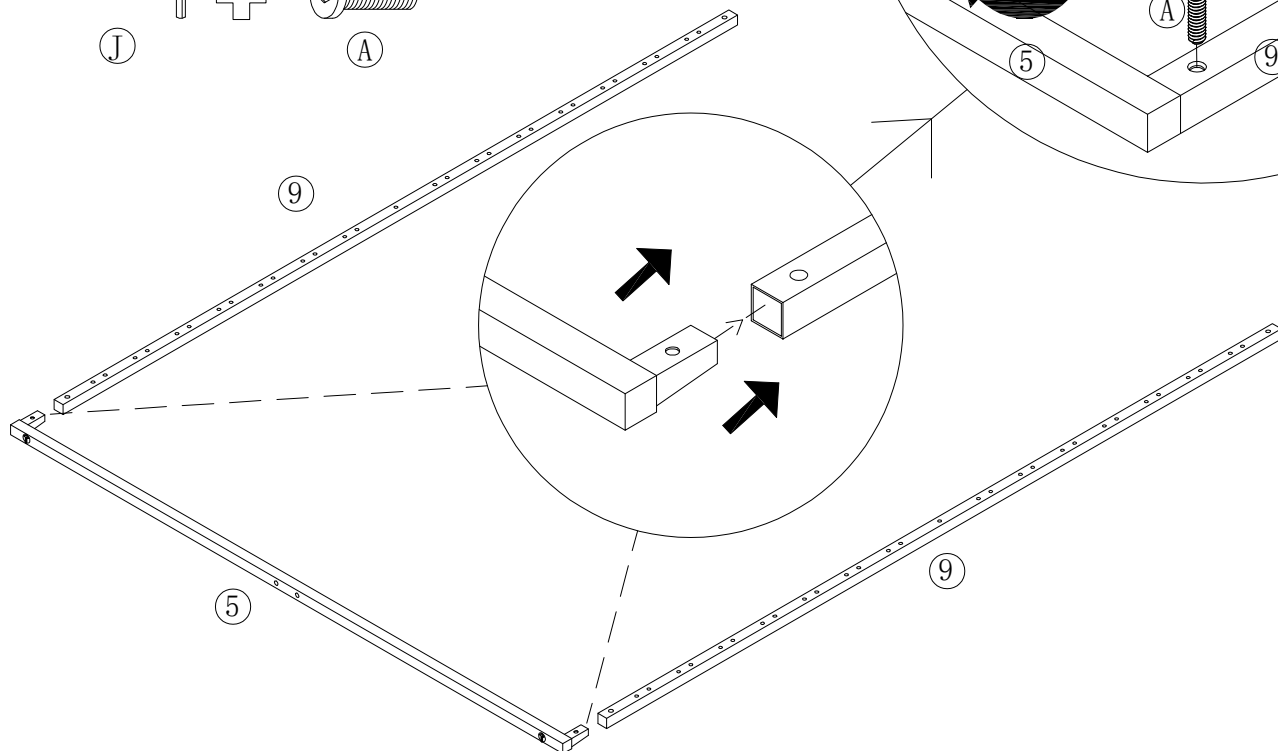
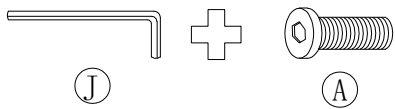

# STEP 10

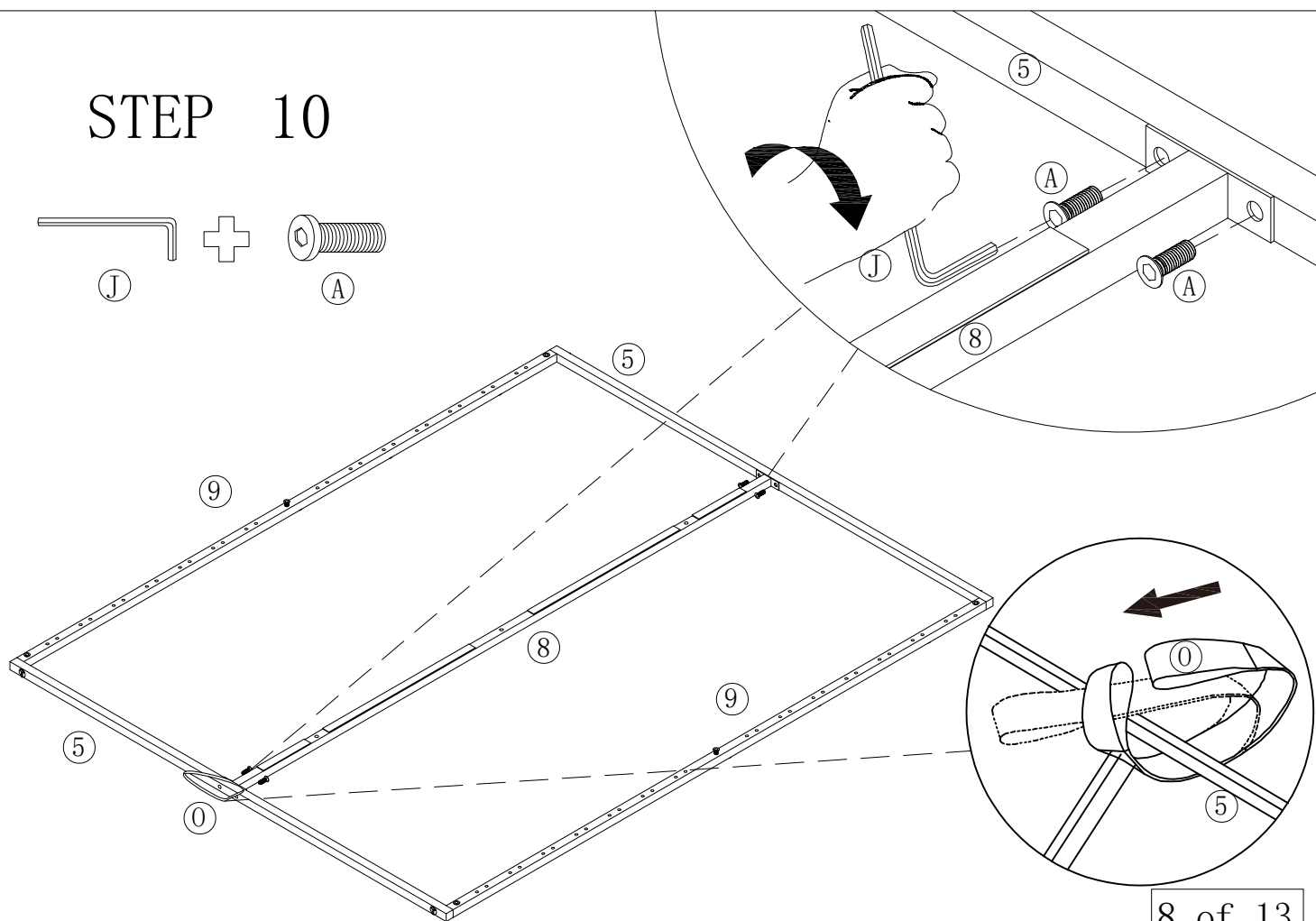
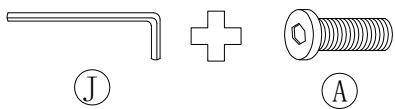

# STEP 11

Caution!

(A) or (B)

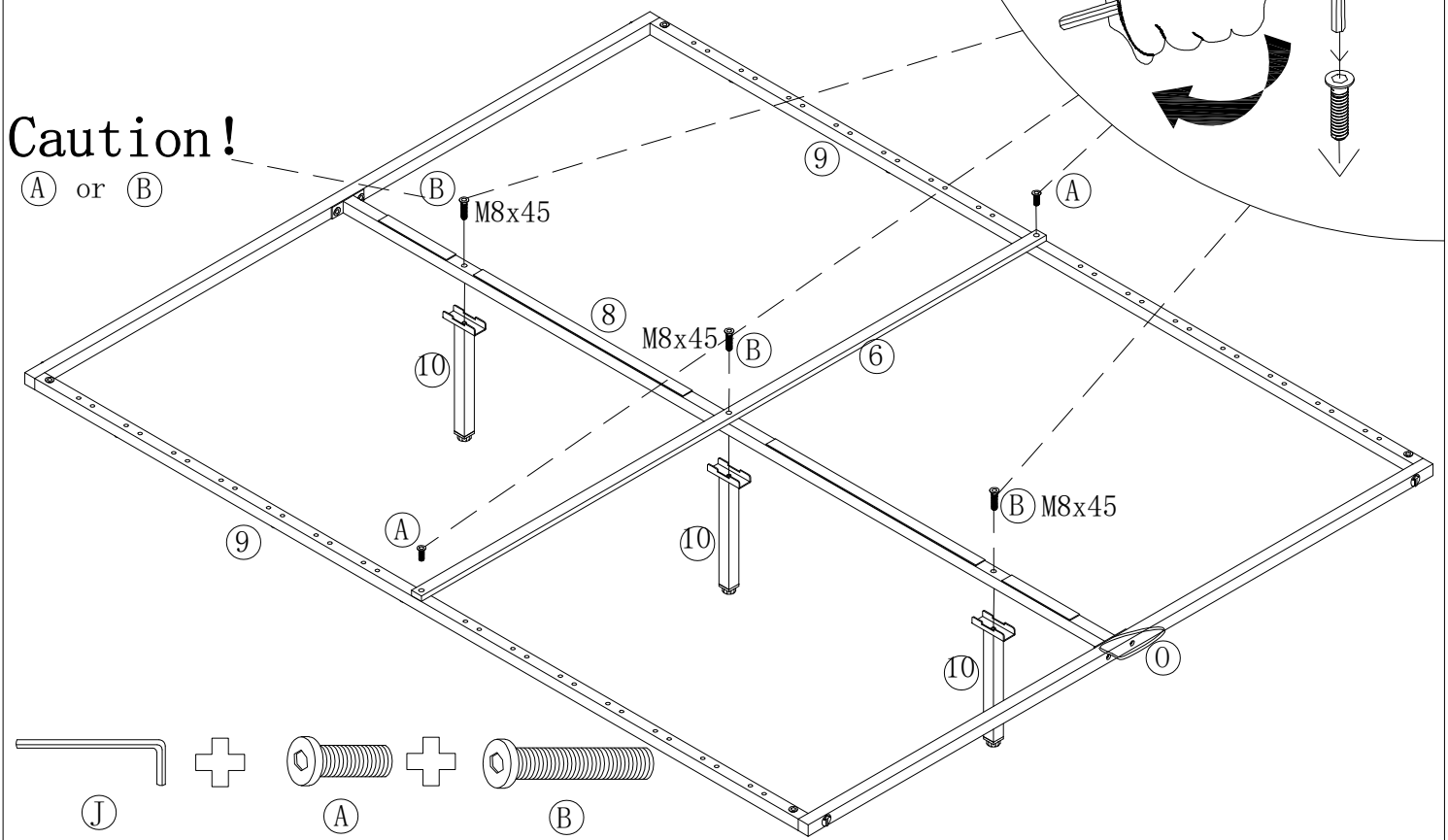

# STEP 12

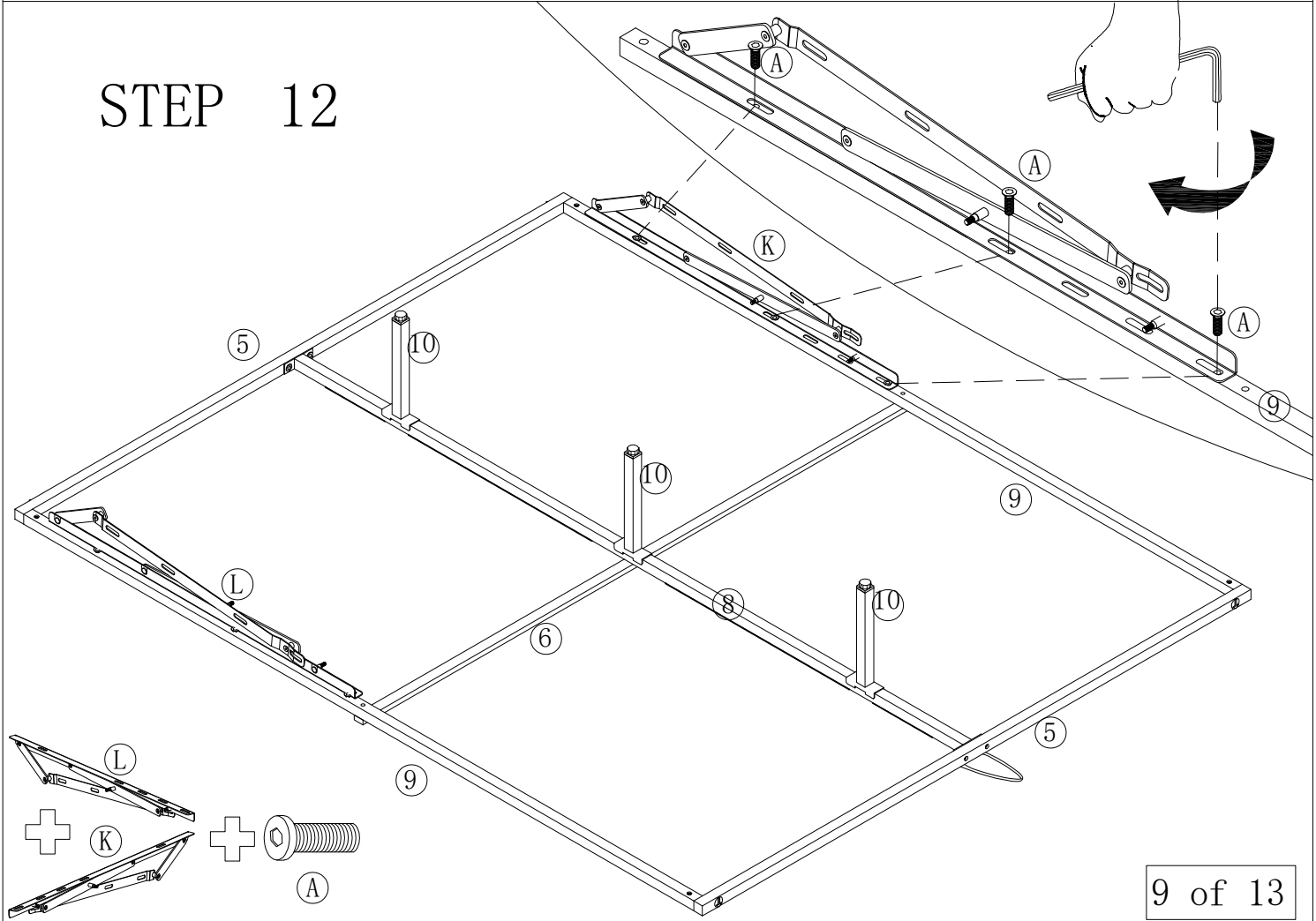

# STEP 12

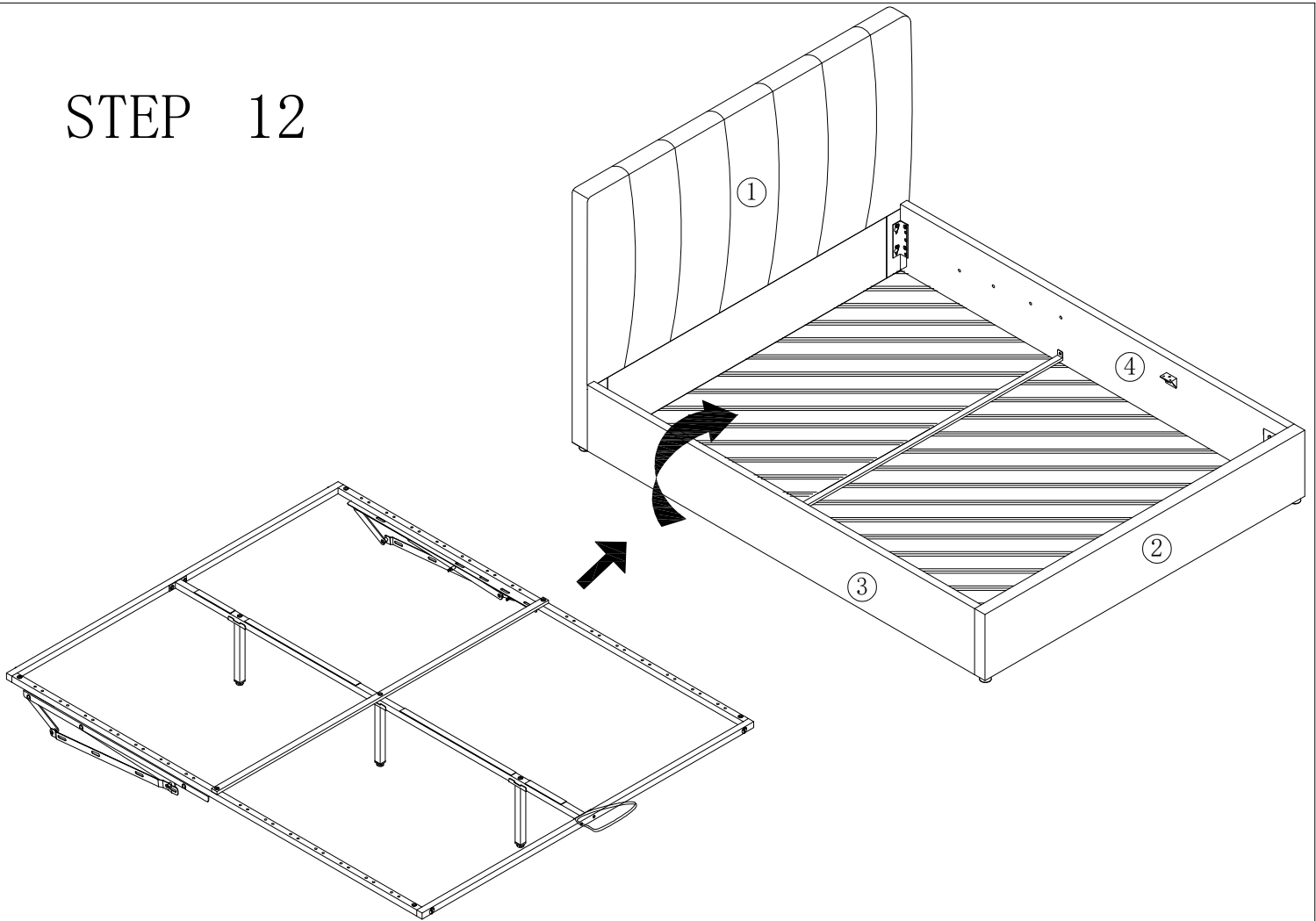

# STEP 13

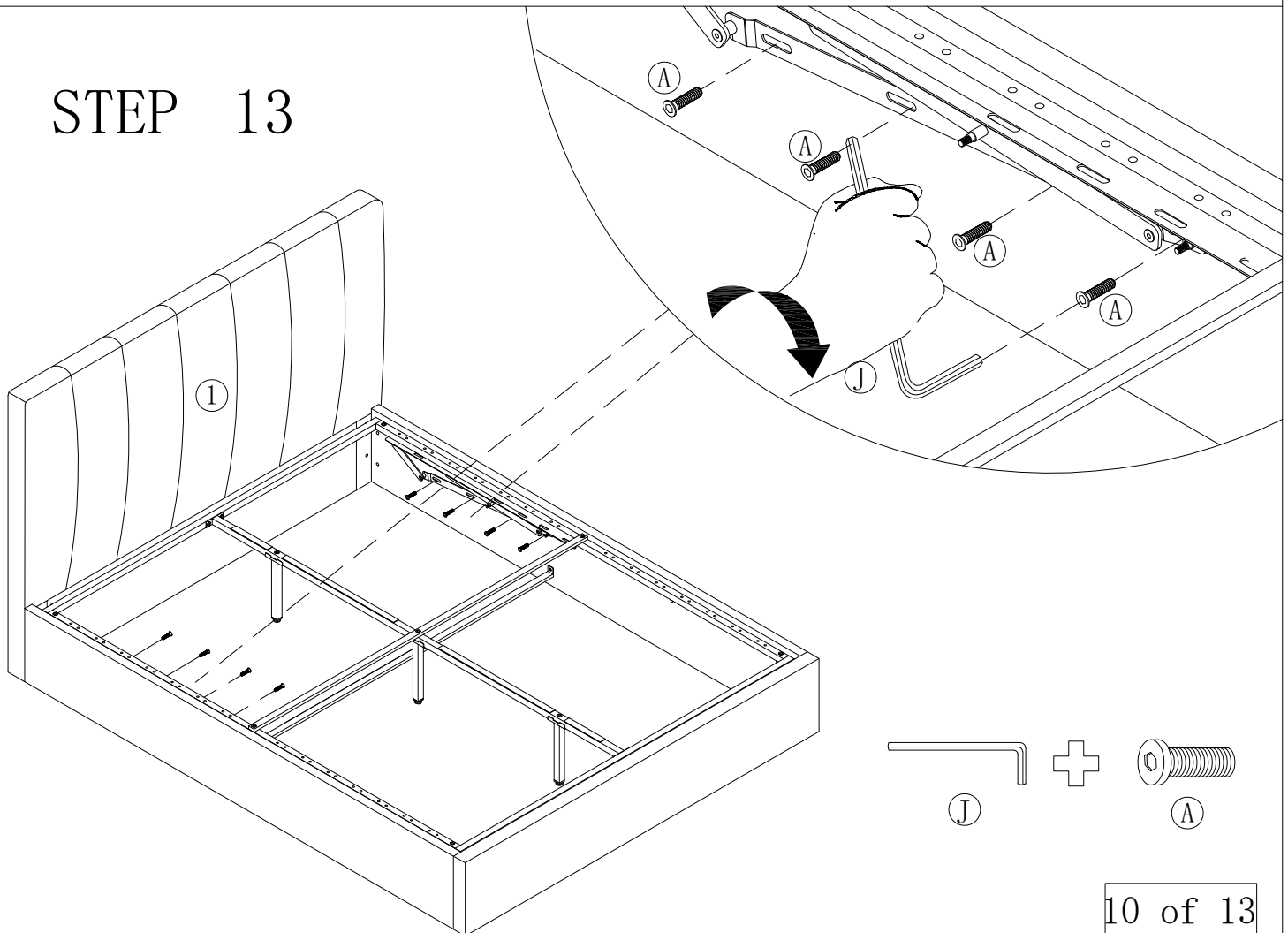

# STEP 14

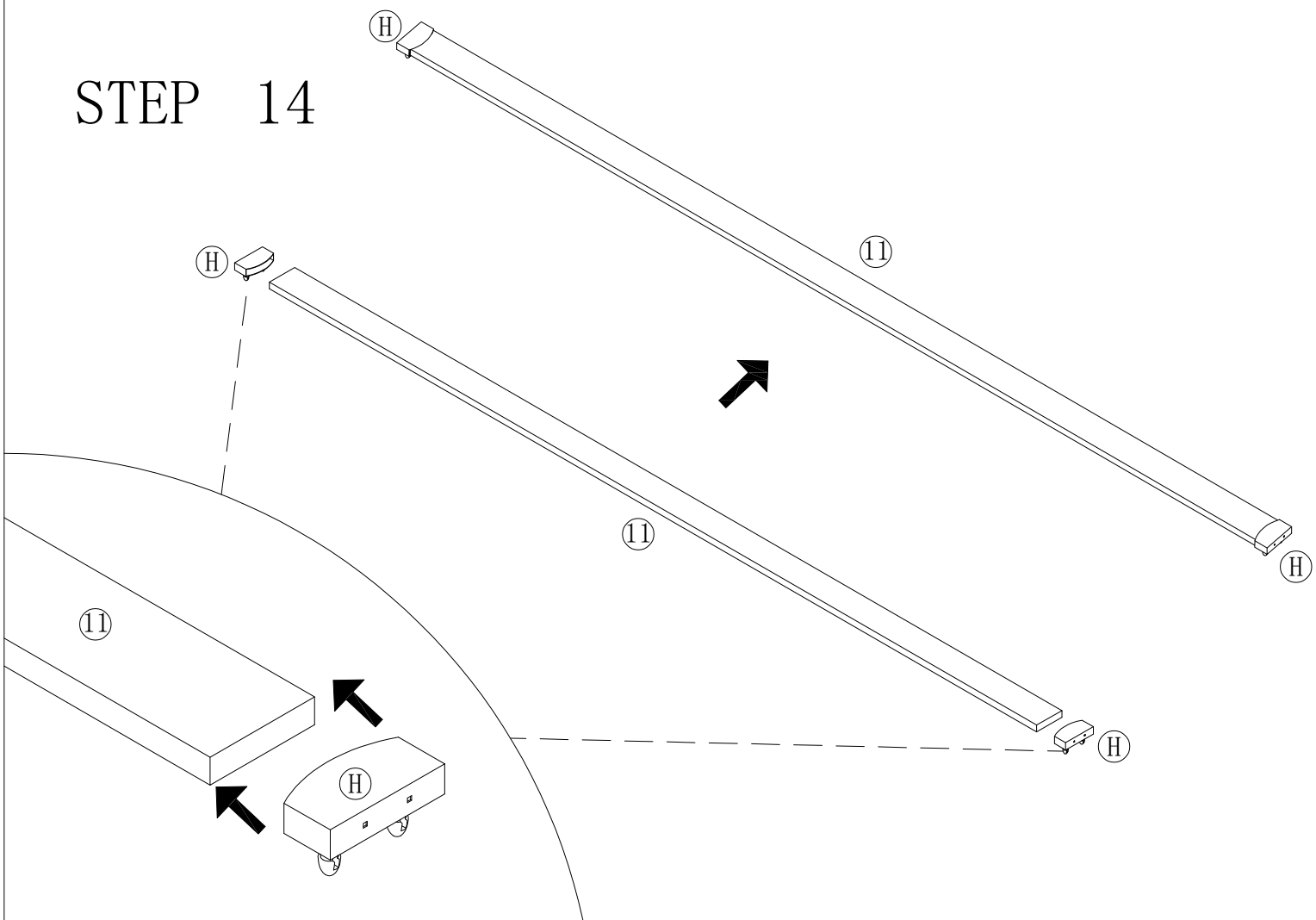

# STEP 15

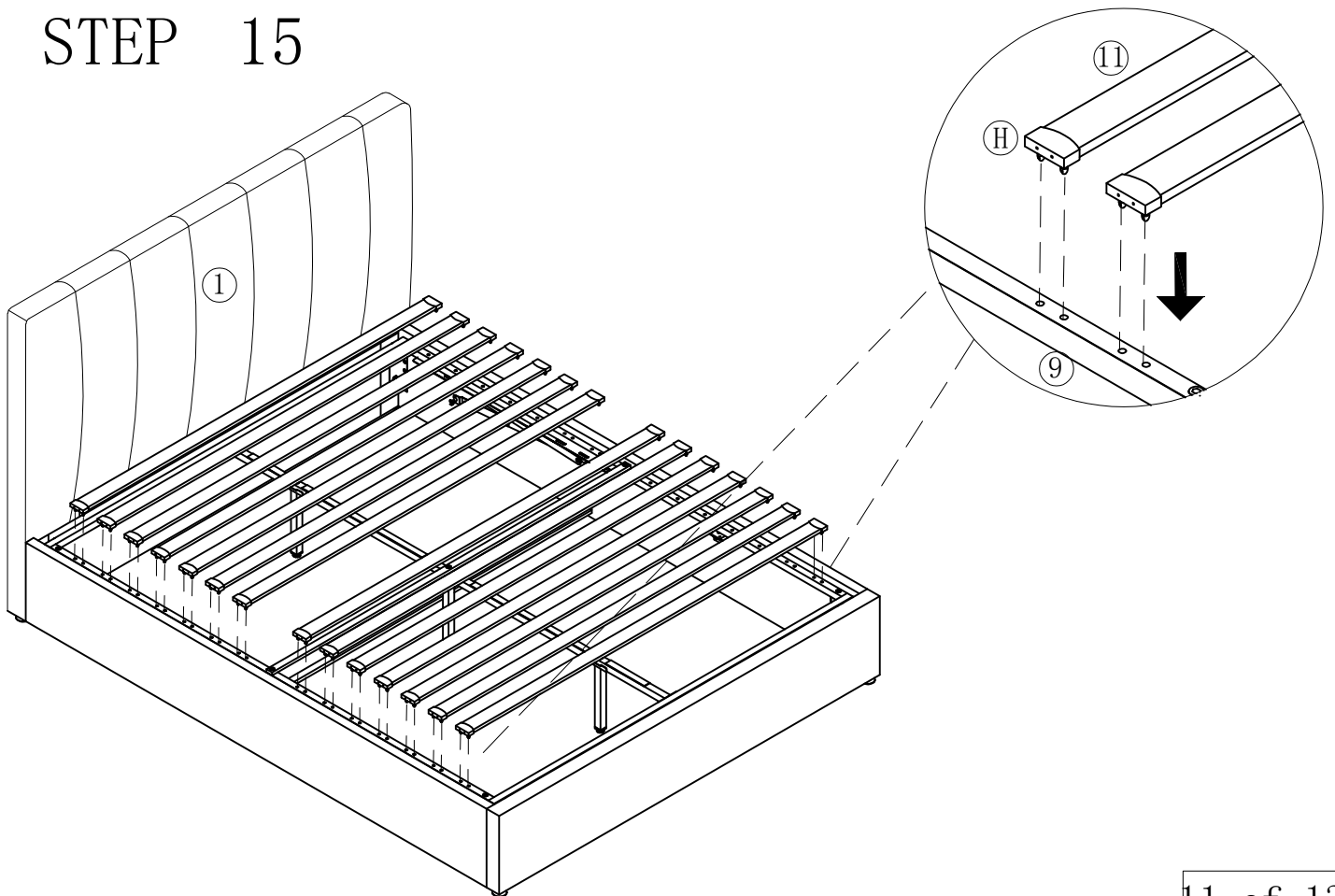

# STEP 16

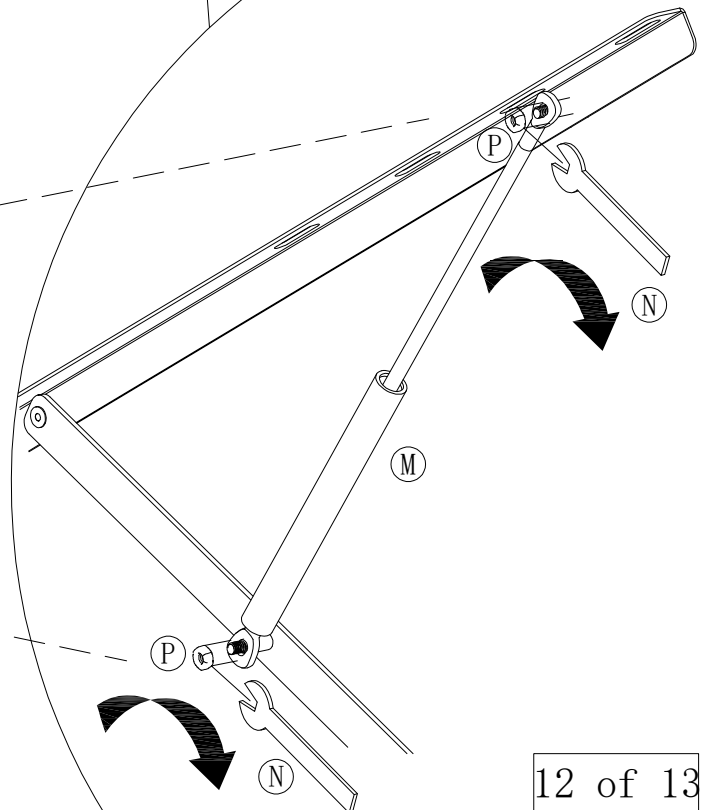
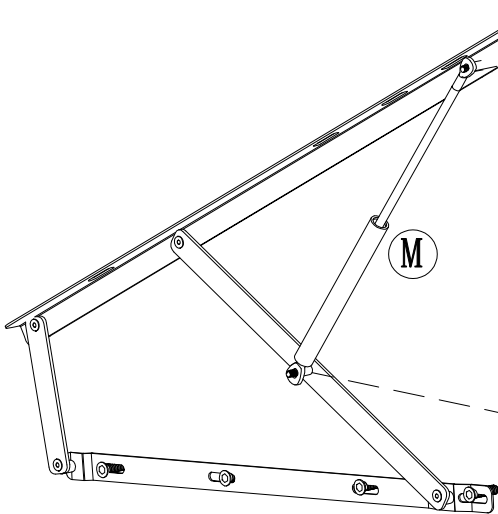
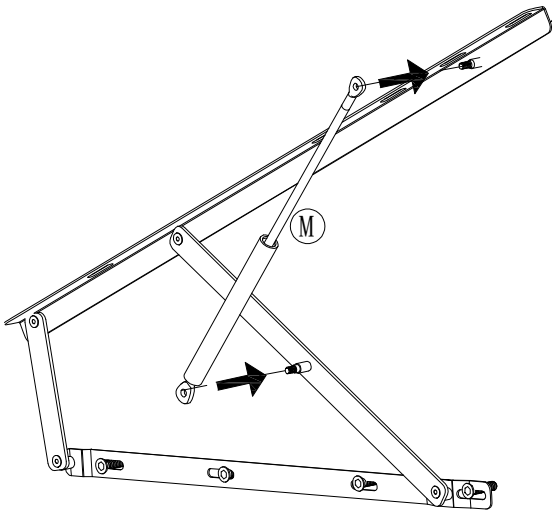
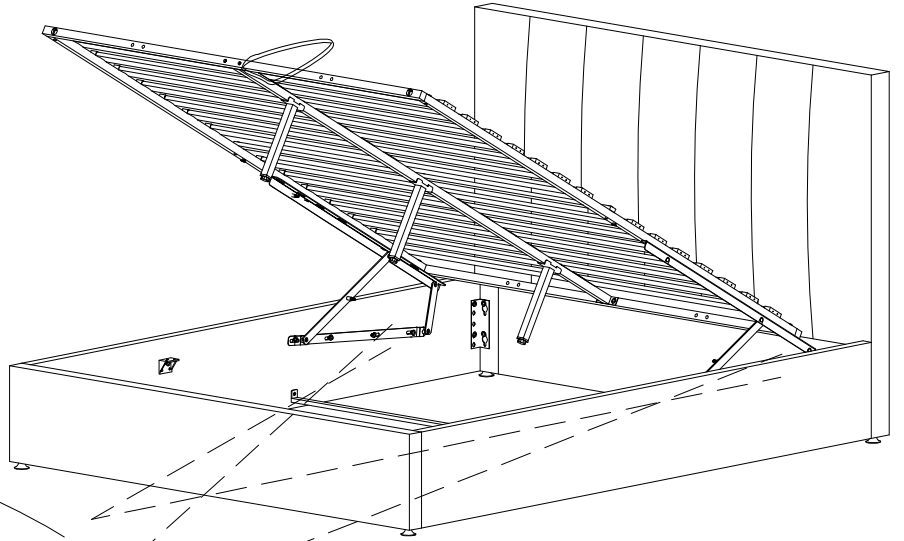
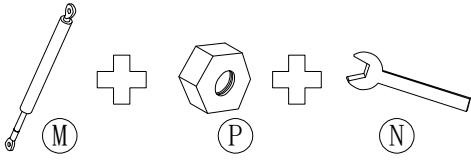

# STEP 17

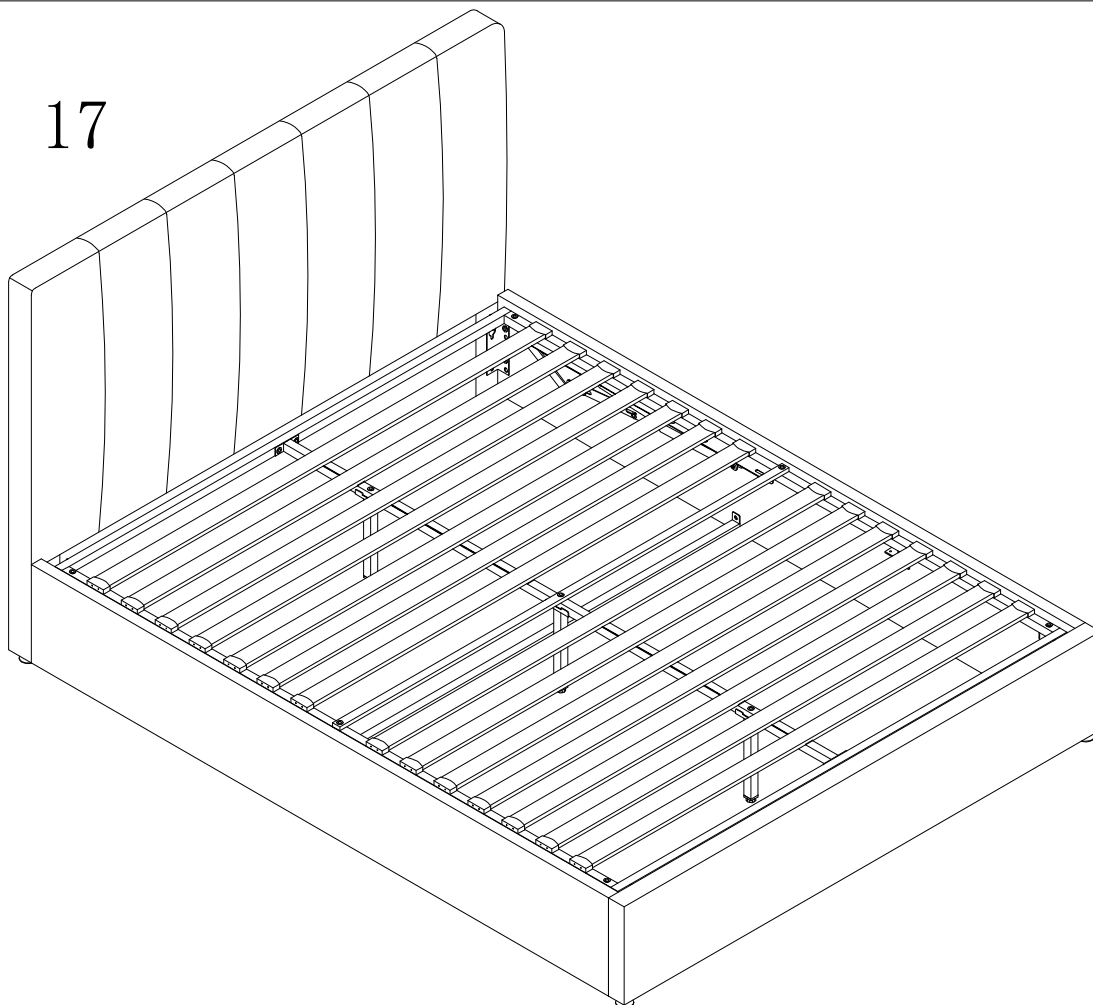

## IMPORTANT NOTICE OTTOMAN OPERATING INSTRUCTIONS

Once your bed frame is completely assembled, the slat unit will not operate correctly unless a mattress is placed on the slat frame. Position the mattress on the slat frame whilst it is in the closed position.

PLEASE NOTE - It takes a lot of force to make the initial movement of the ottoman. This is a design feature of the product so that it does not fall shut - the nearer to being closed the ottoman is, the easier it is to move. When the ottoman is almost shut, it will close completely under its own weight.

When lowering the slat unit for the first time, take care to make sure it does not rub unevenly on the inside face of the side rails. If it does, the bed has been assembled slightly out of square. This can be rectified by moving the foot end of the bed slightly to the left or right whilst leaving the head end stationary.

### PISTONS

The pistons used in the construction of this product are extremely strong and cannot be operated by hand when taken off the ottoman. All pistons are tested for correct pressure and operation before being attached to the slat unit.

Initially it might appear that the pistons are very stiff when opening and closing the ottoman.

### THIS IS PERFECTLY NORMAL

When fully assembled and the mattress is in position, please raise and lower the ottoman 4/5 times to ensure the gas piston are fully lubricated.

