

# ASSEMBLY INSTRUCTION

TV 51

2Sliding Doors & 2Drawers

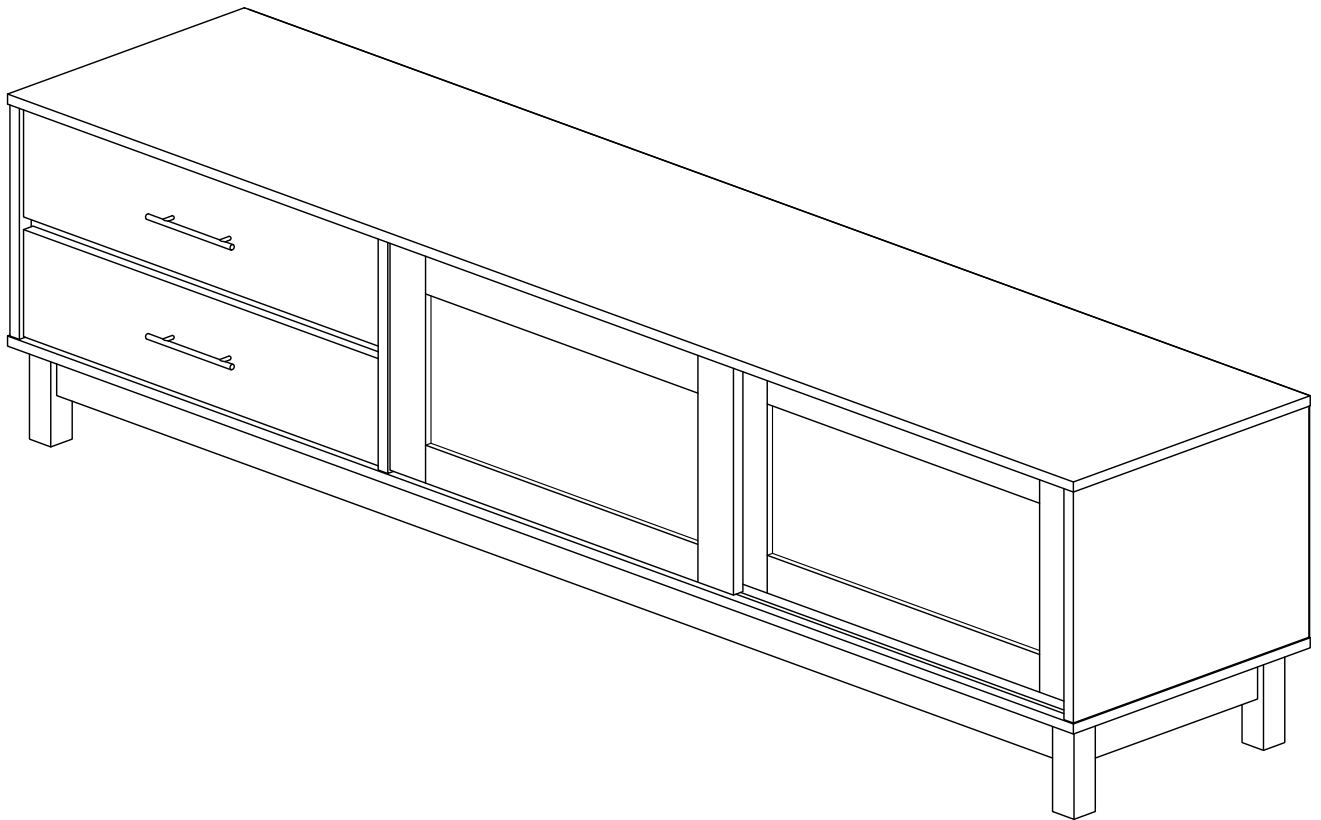

# ASSEMBLY INSTRUCTION

## TV 51 2Sliding Doors & 2Drawers

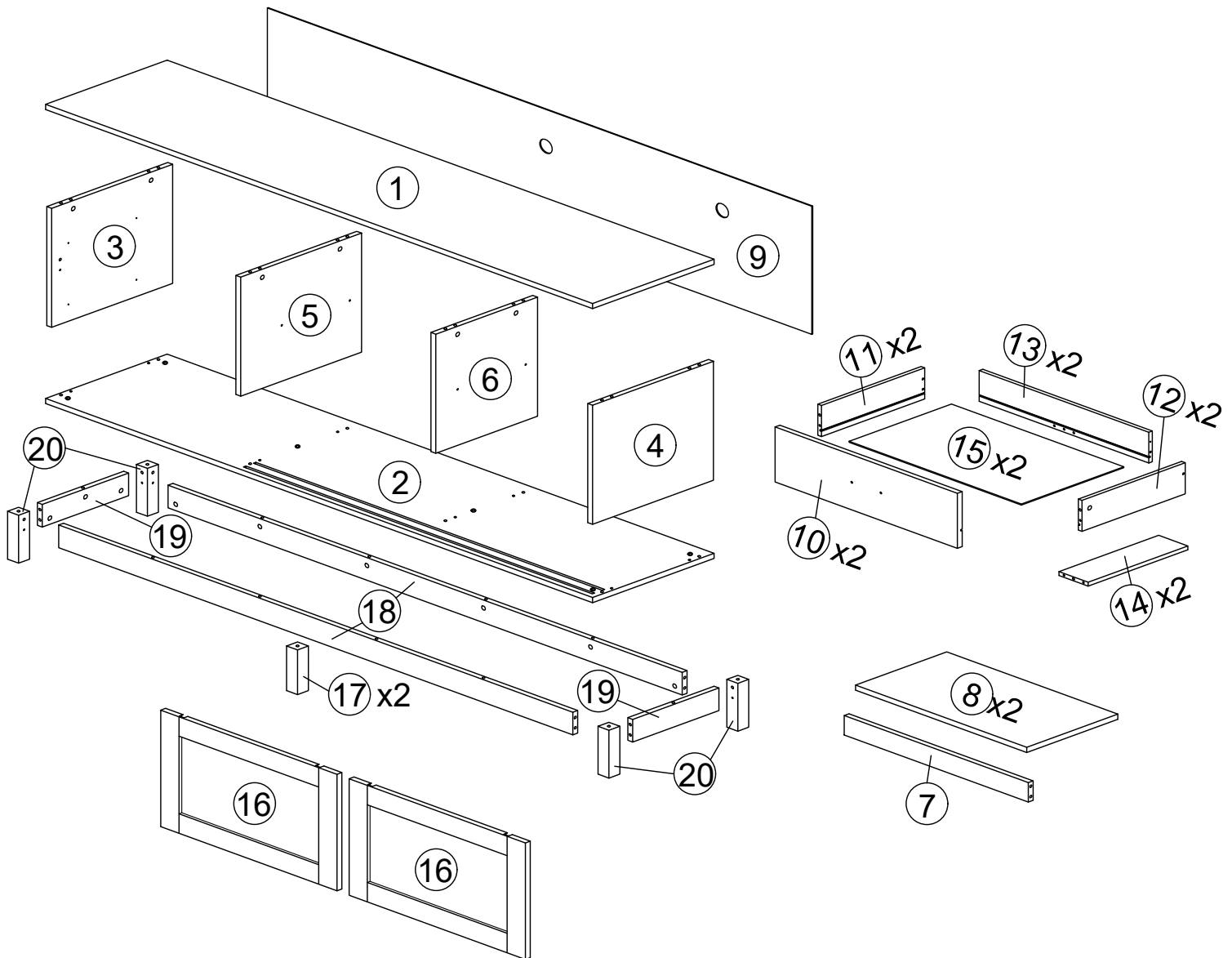



# ASSEMBLY INSTRUCTION

## TV 51

### 2Sliding Doors & 2Drawers

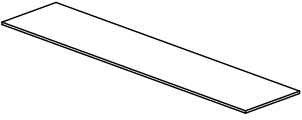
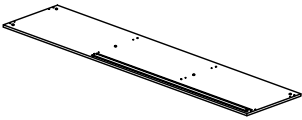
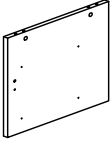
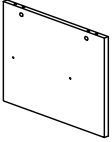
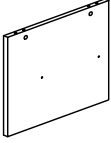
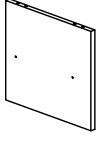
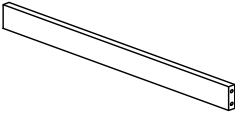
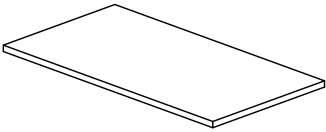
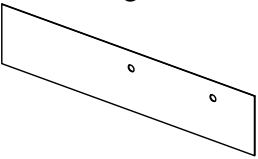
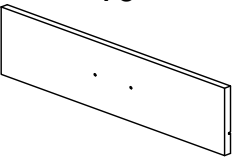
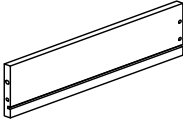
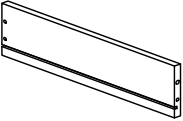
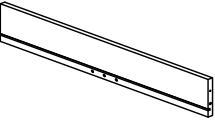
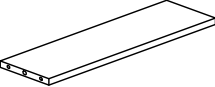
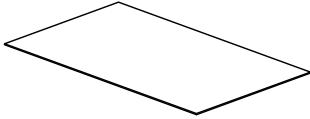
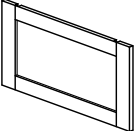
#### PART LIST

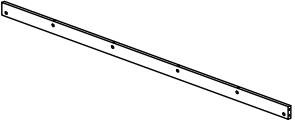
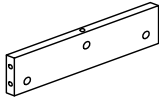
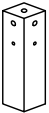













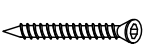

<p>1</p>  <p>Top Panel 1 PC</p>	<p>2</p>  <p>Bottom Panel 1 PC</p>	<p>3</p>  <p>Side Panel L 1 PC</p>	<p>4</p>  <p>Side Panel R 1 PC</p>
<p>5</p>  <p>Center Panel L 1 PC</p>	<p>6</p>  <p>Center Panel R 1 PC</p>	<p>7</p>  <p>Middle Support 1 PC</p>	<p>8</p>  <p>Shelf Panel 2 PCS</p>
<p>9</p>  <p>Back Panel 1 PC</p>	<p>10</p>  <p>Drawer Head 2 PCS</p>	<p>11</p>  <p>Drawer Side L 2 PCS</p>	<p>12</p>  <p>Drawer Side R 2 PCS</p>
<p>13</p>  <p>Drawer Back 2 PCS</p>	<p>14</p>  <p>Drawer Support 2 PCS</p>	<p>15</p>  <p>Drawer Panel 2 PCS</p>	<p>16</p>  <p>Door Panel L/R 2 PCS</p>
<p>17</p>  <p>Center Leg 2 PCS</p>	<p>18</p>  <p>Leg Support Middle 2 PCS</p>	<p>19</p>  <p>Leg Support Side 2 PCS</p>	<p>20</p>  <p>Side Leg 4 PCS</p>

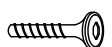
# ASSEMBLY INSTRUCTION

## TV 51

## 2Sliding Doors & 2Drawers

### HARDWARE LIST

<p><b>A</b></p>  <p>Camlock 15MM 34 PCS</p>	<p><b>B</b></p>  <p>Camlock Bolt 15MM 34 PCS</p>	<p><b>C</b></p>  <p>M8x25MM Wood Dowel 26 PCS</p>	<p><b>D</b></p>  <p>M6x30MM Wood Dowel 16 PCS</p>
<p><b>E</b></p>  <p>CB Screw M3.5x16MM 40 PCS</p>	<p><b>F</b></p>  <p>M4x38MM Screw 6 PCS</p>	<p><b>G</b></p>  <p>Csk M6x50MM 8 PCS</p>	<p><b>H</b></p>  <p>K455 Roller 4 PCS</p>
<p><b>I</b></p>  <p>M6x30MM JCBC Screw 6 PCS</p>	<p><b>J</b></p>  <p>PVC Nail Leg 5/8 4 PCS</p>	<p><b>K</b></p>  <p>Shelf Support 8 PCS</p>	<p><b>L</b></p>  <p>Drawer Slide 12" 4 PCS</p>
<p><b>M</b></p>  <p>Nail 5/8 25 PCS</p>	<p><b>N</b></p>  <p>Metal Bar Handle 96MM 2 PCS</p>	<p><b>O</b></p>  <p>Handle Screw M4x25MM 4 PCS</p>	<p><b>P</b></p>  <p>M4 Allen Key 1 PC</p>

# ASSEMBLY INSTRUCTION

## Step 1

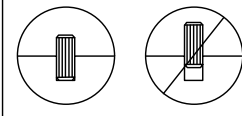

Required/Requis/Requerido

x16

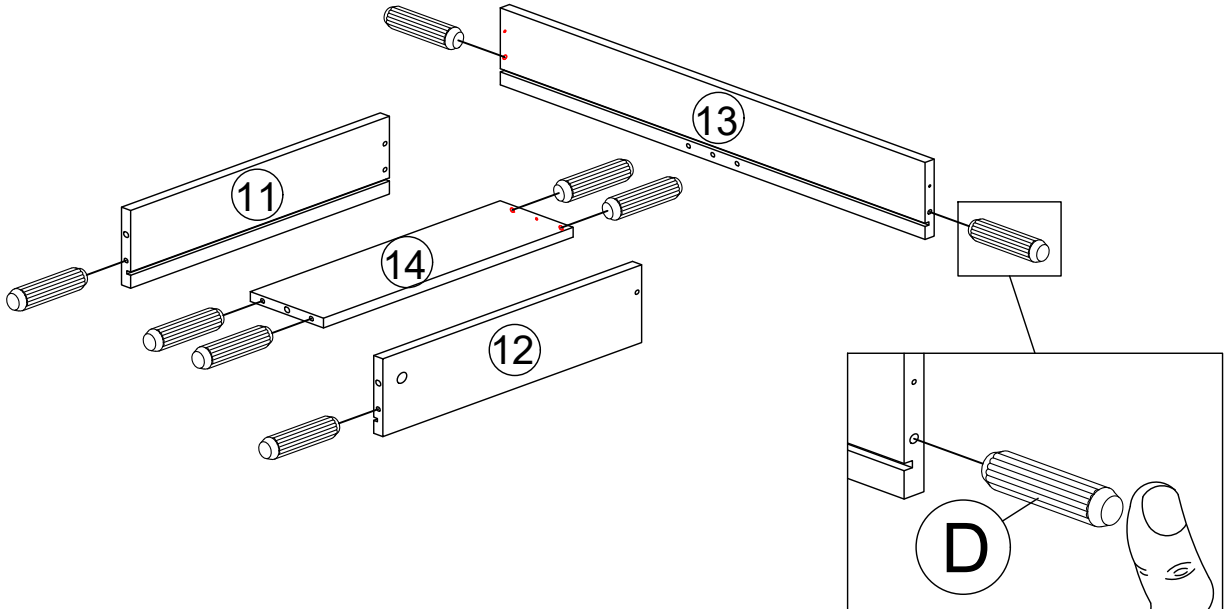
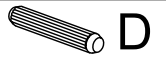

x2

## Step 2

Required/Requis/Requerido

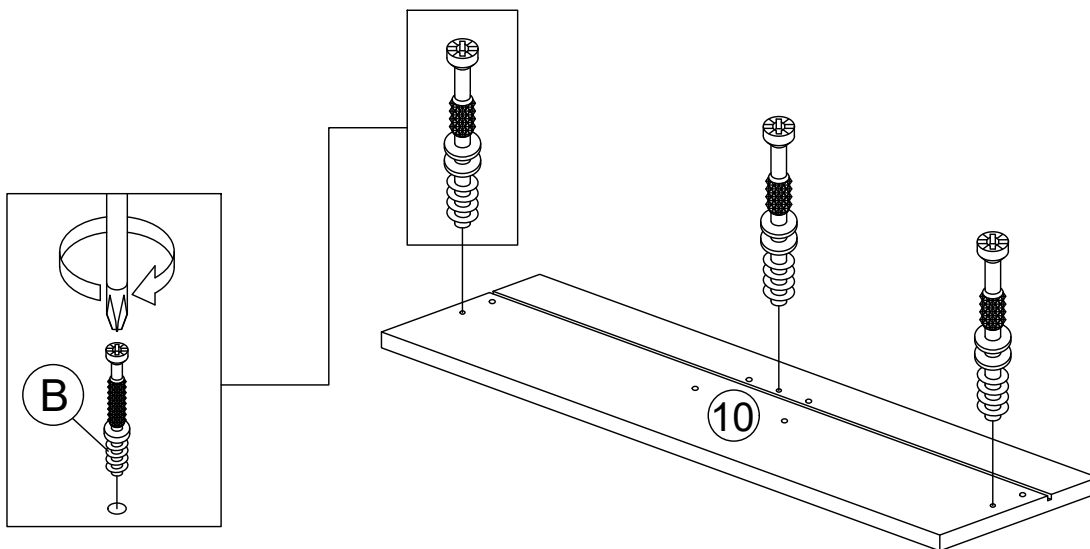

x6



x2

# ASSEMBLY INSTRUCTION

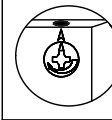
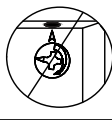
## Step 3

			Required/Requis/Requerido
			x6
			A

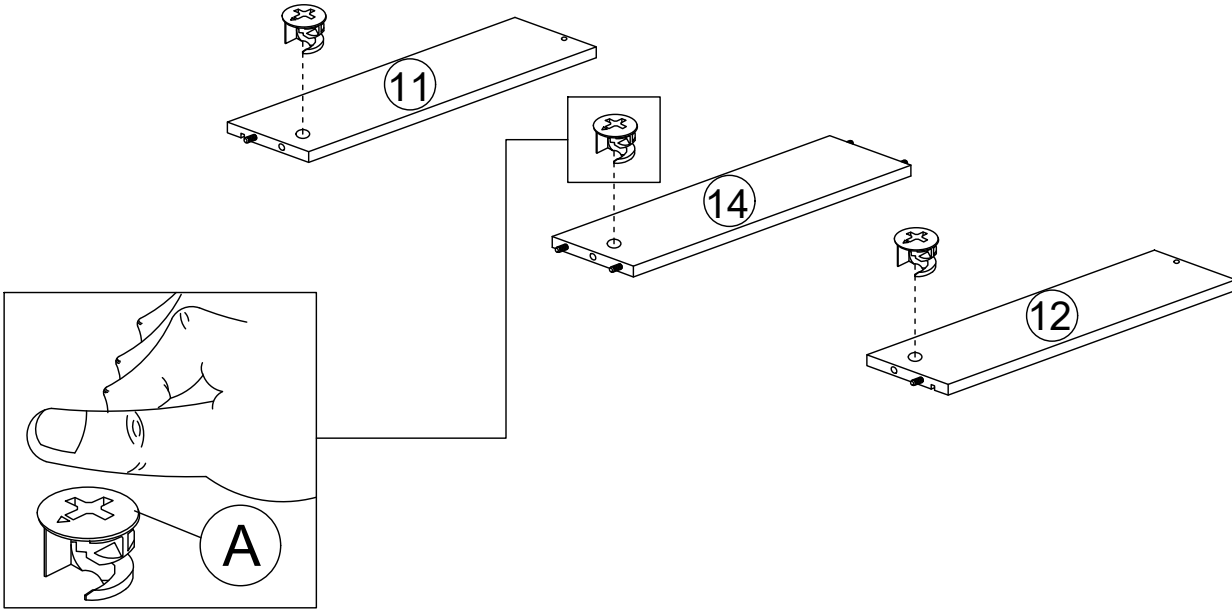

## Step 4

Required/Requis/Requerido	
x6	 F

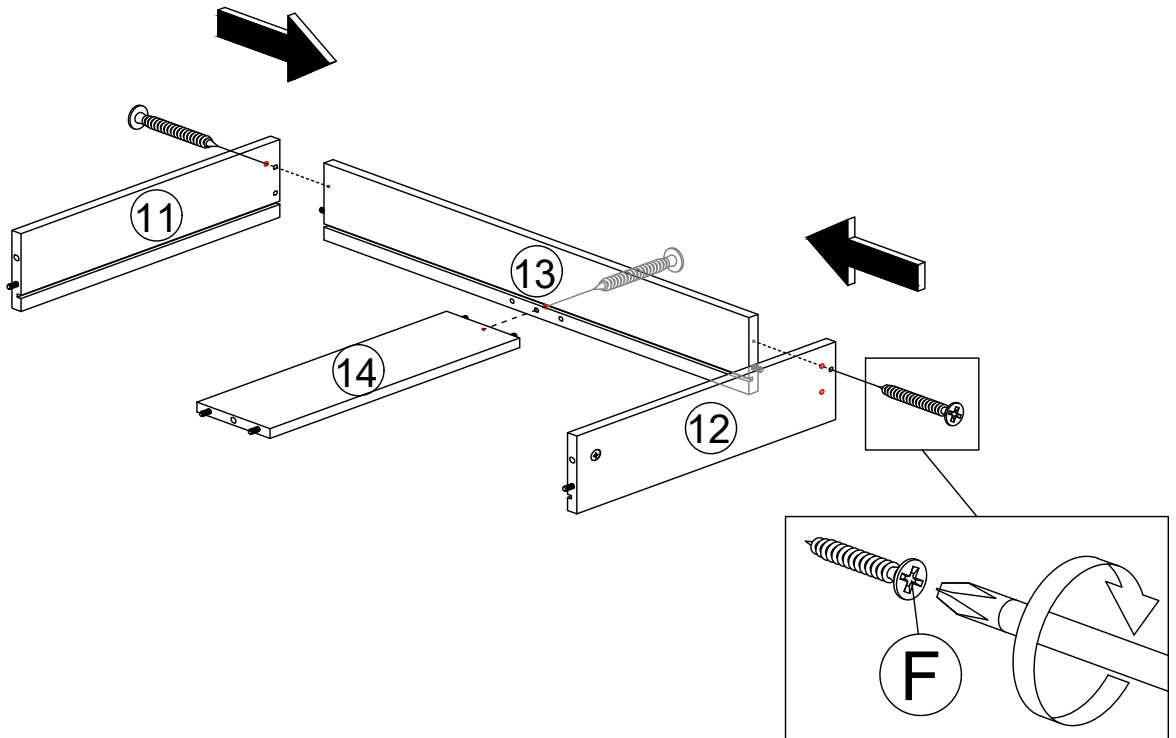

x2

# ASSEMBLY INSTRUCTION

## Step 5

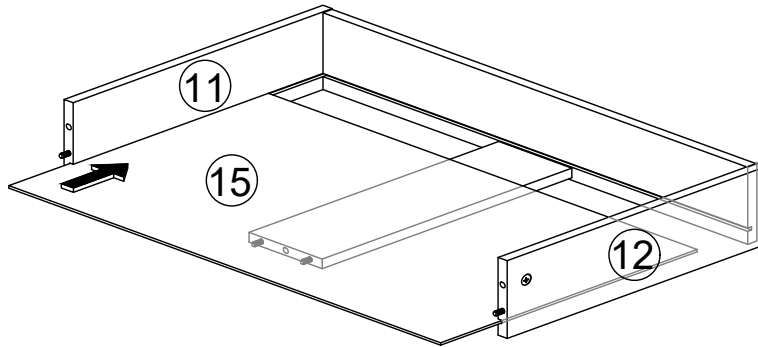

x2

## Step 6

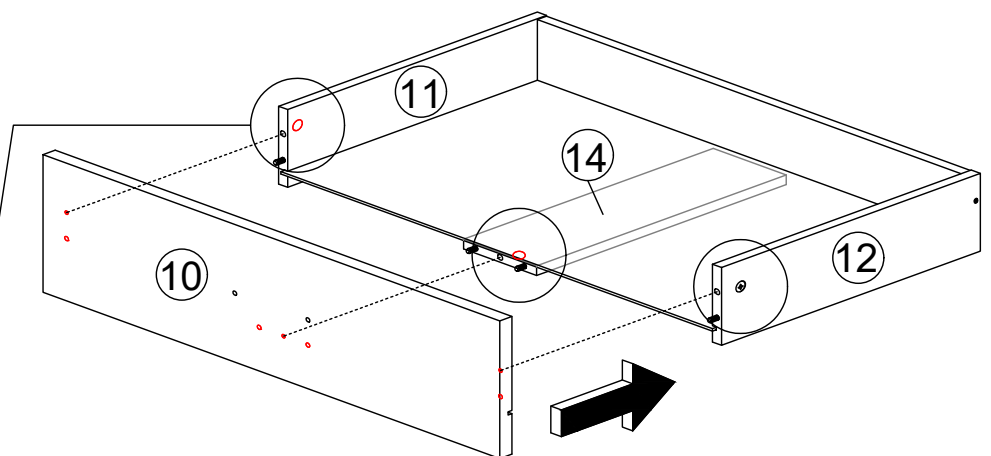
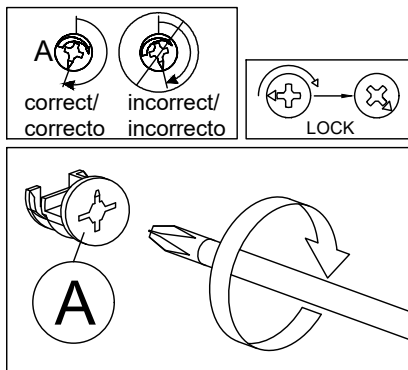

x2

# ASSEMBLY INSTRUCTION

## Step 7

Required/Requis/Requerido

x12  E

x4  L

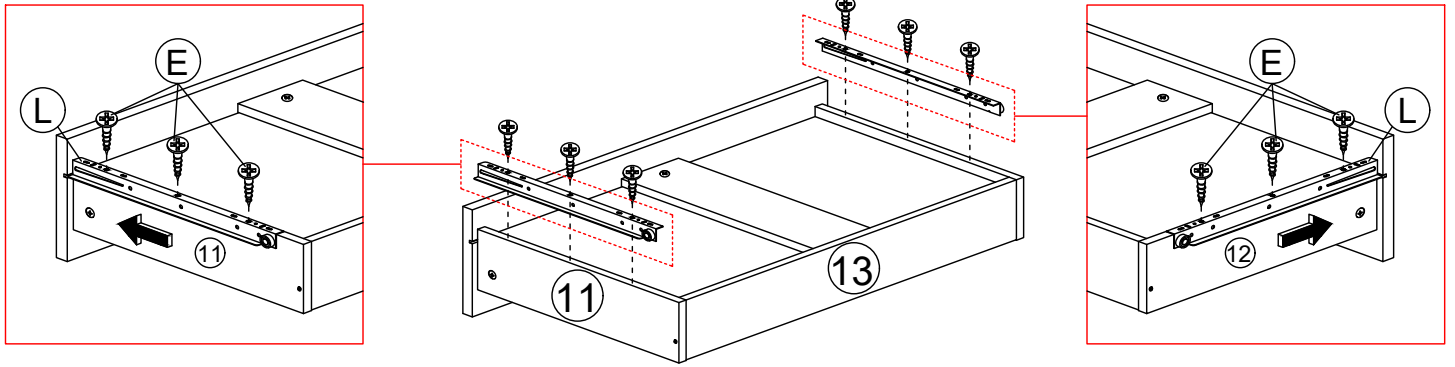

Bottom View

x2

## Step 8

Required/Requis/Requerido

x4  O

x2  N

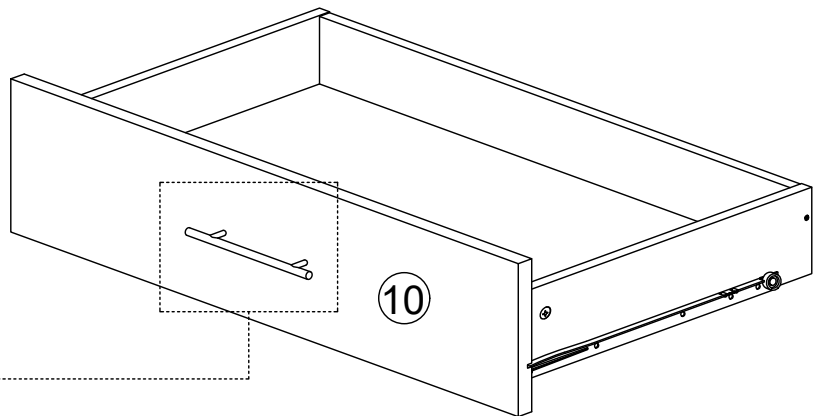
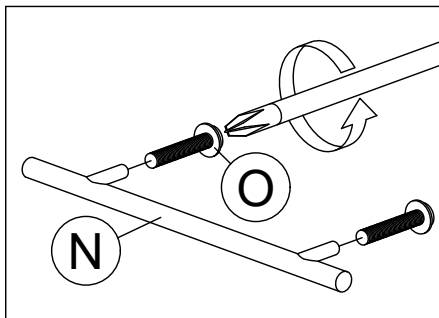

x2

# ASSEMBLY INSTRUCTION

## Step 9

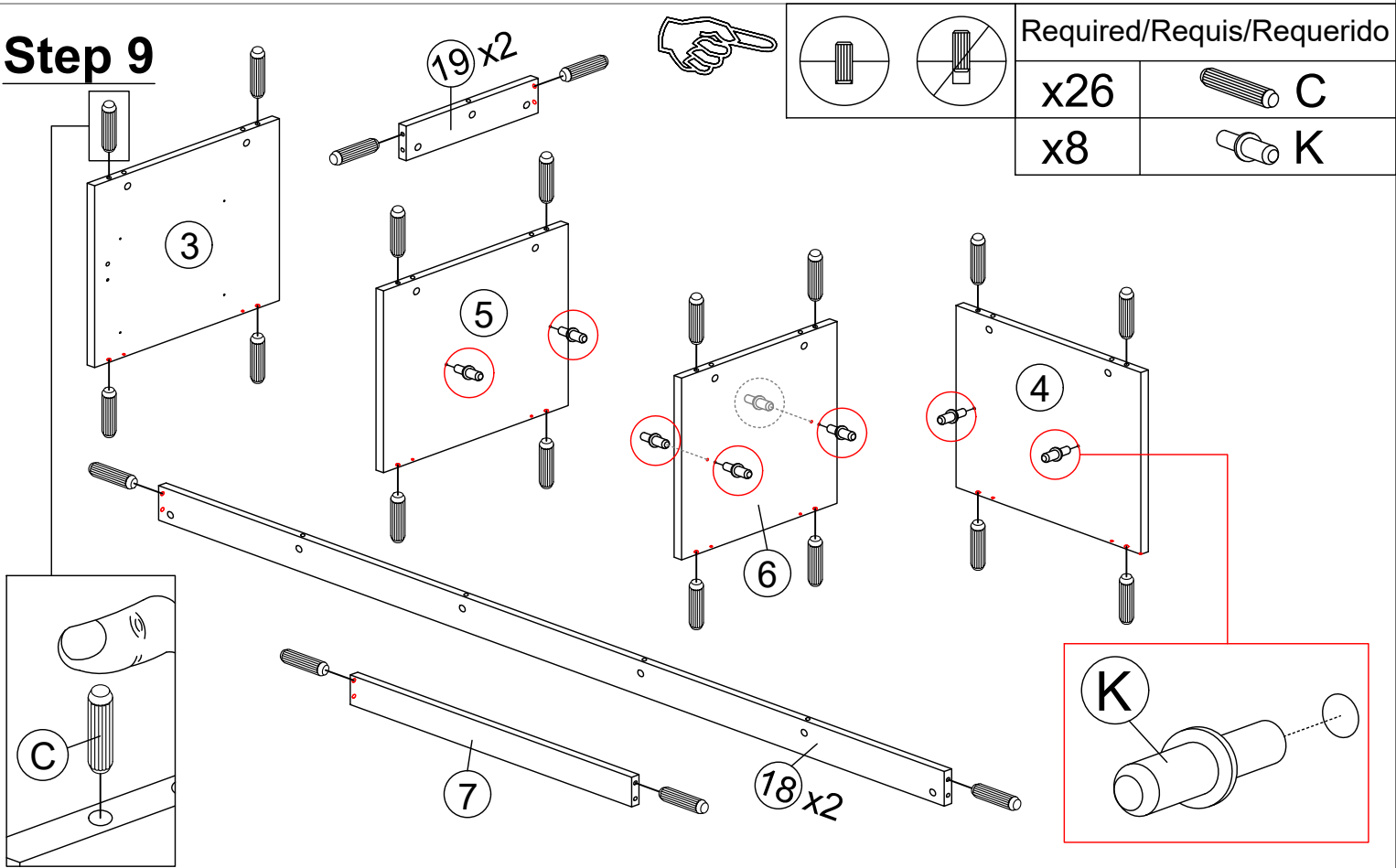

## Step 10

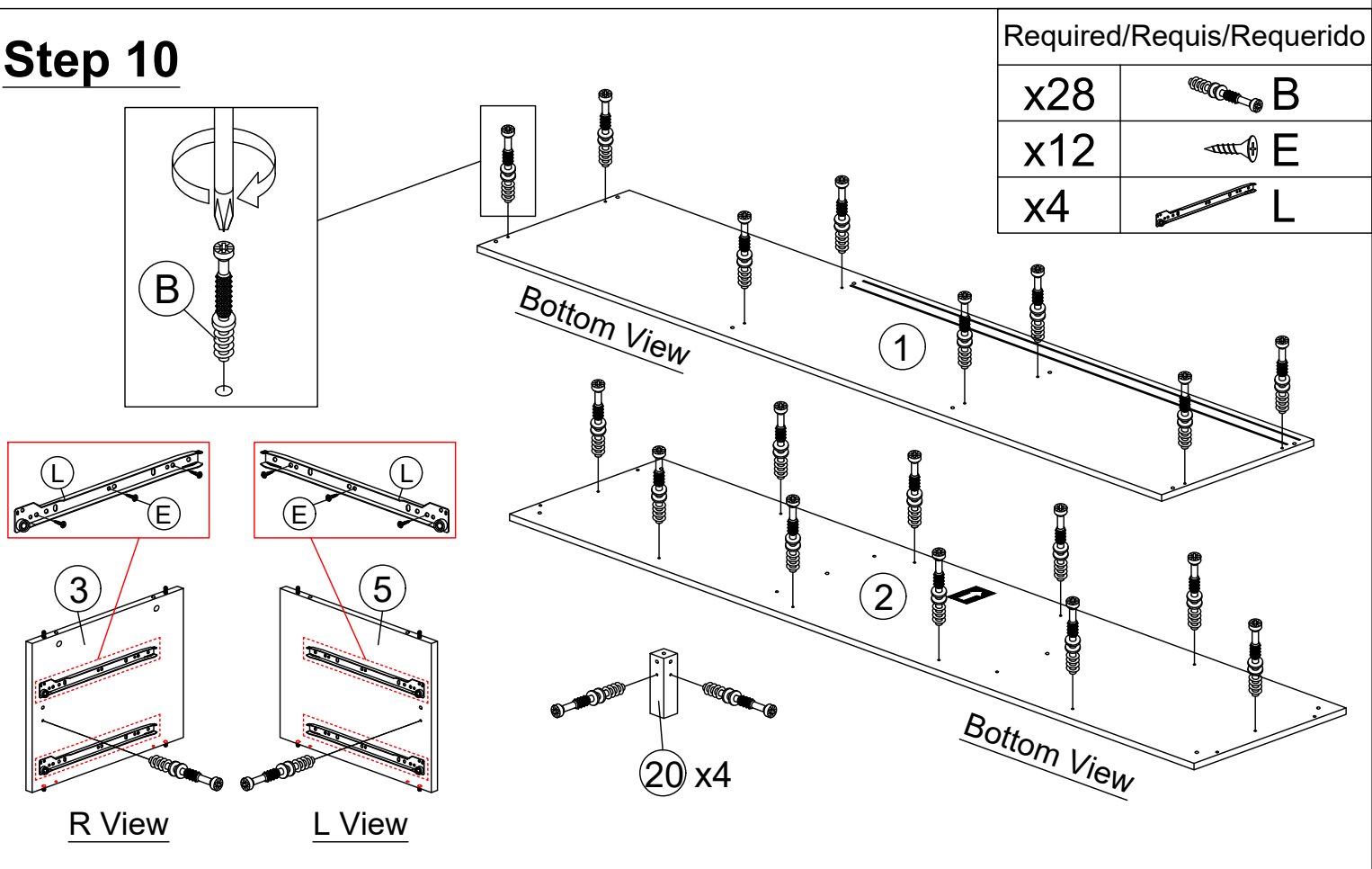

# ASSEMBLY INSTRUCTION

## Step 11

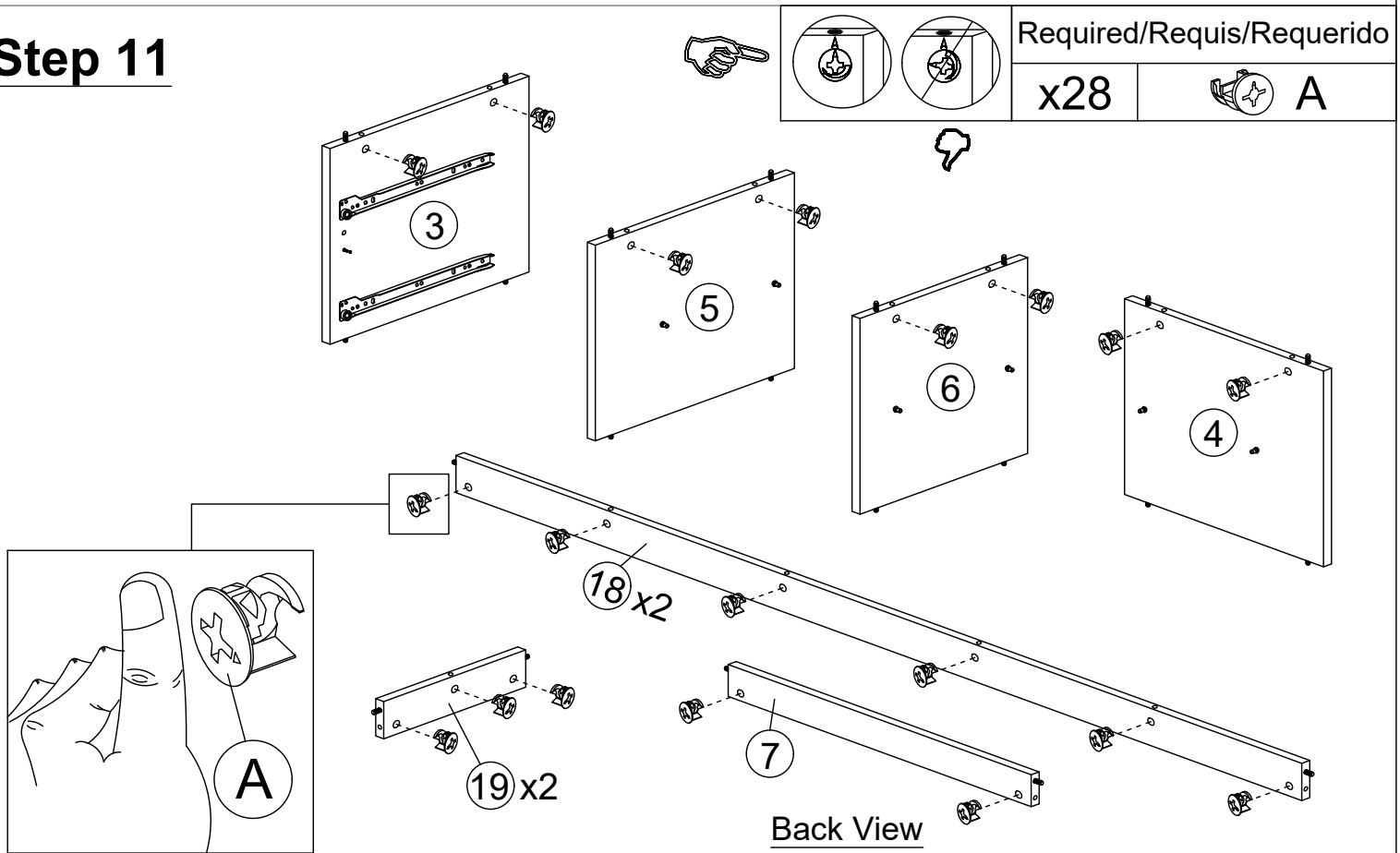

## Step 12

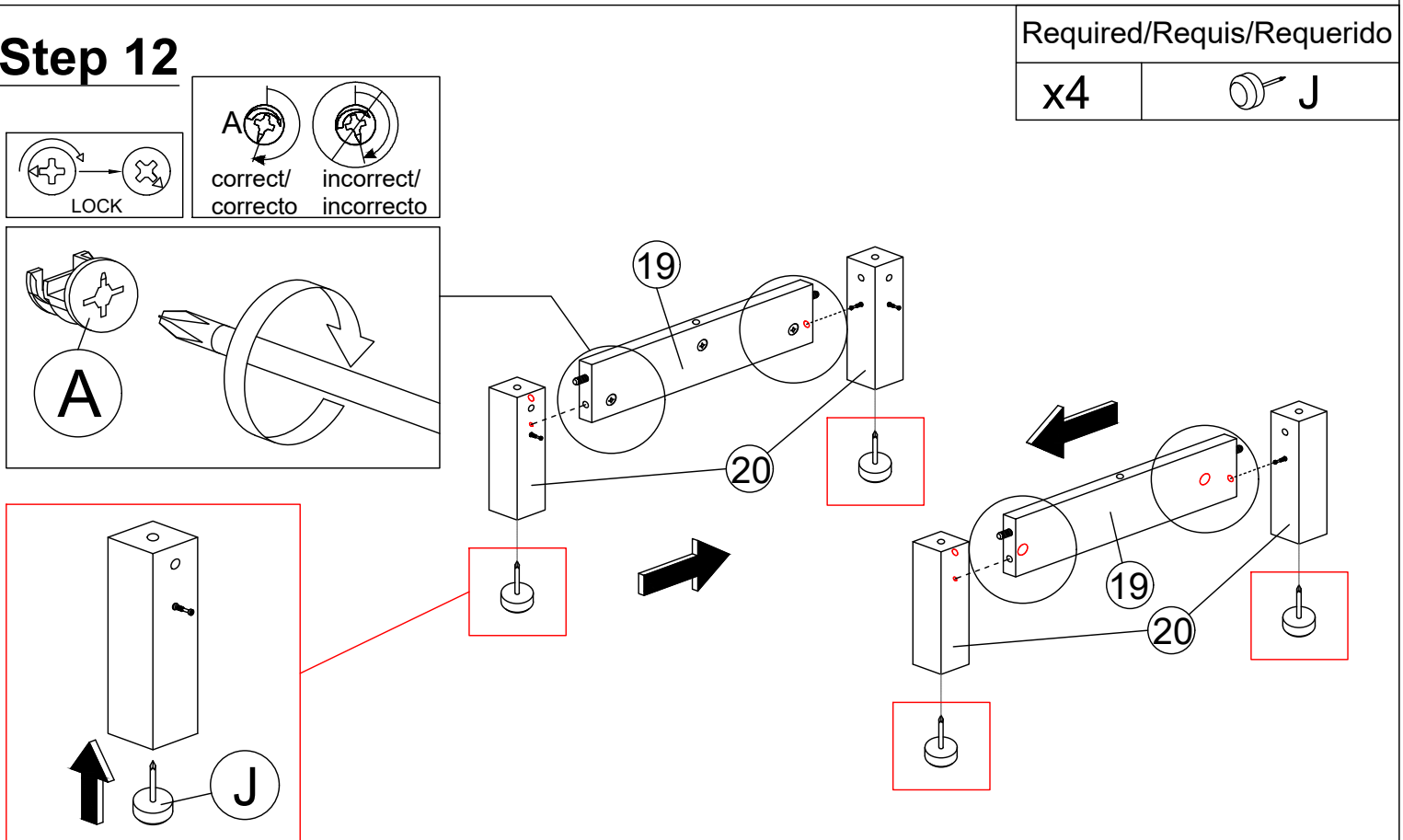

# ASSEMBLY INSTRUCTION

## Step 13

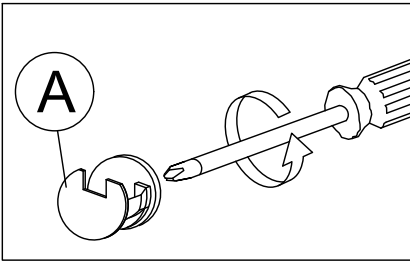
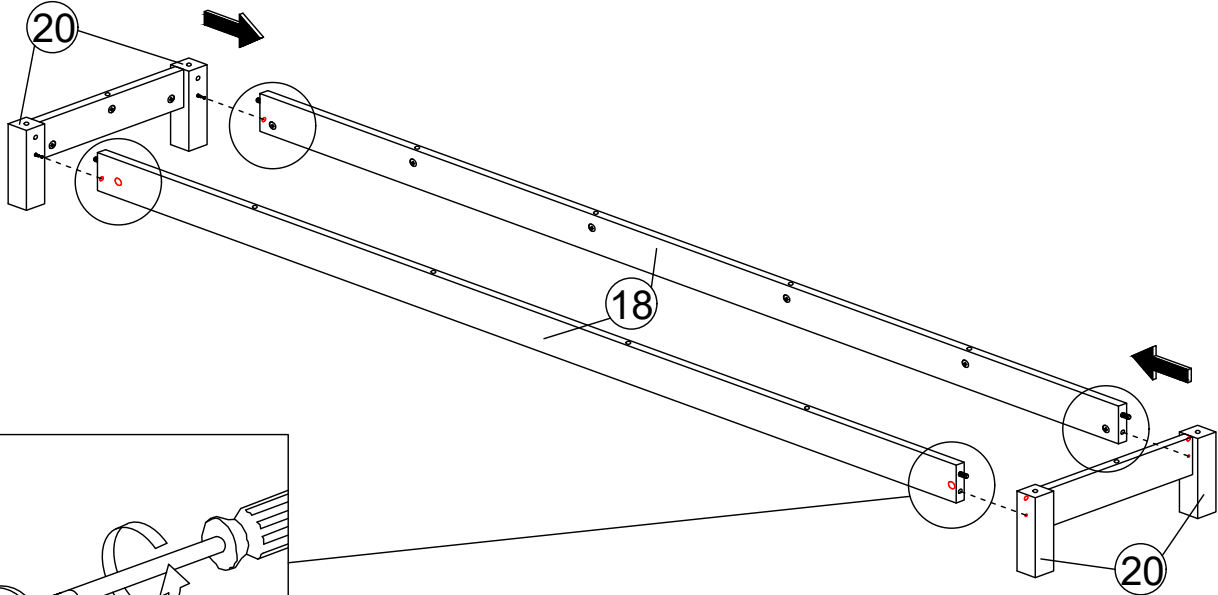
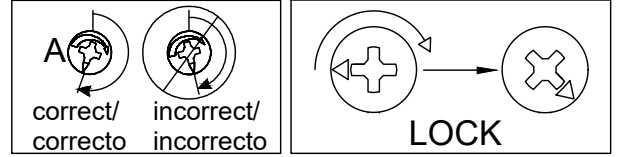

## Step 14

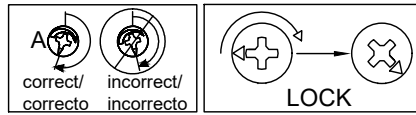

Required/Requis/Requerido

x1	P
x6	I

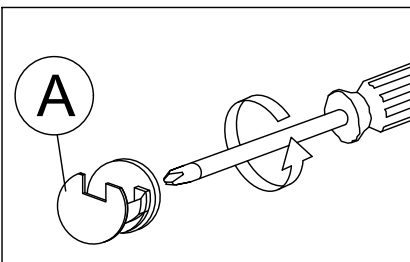
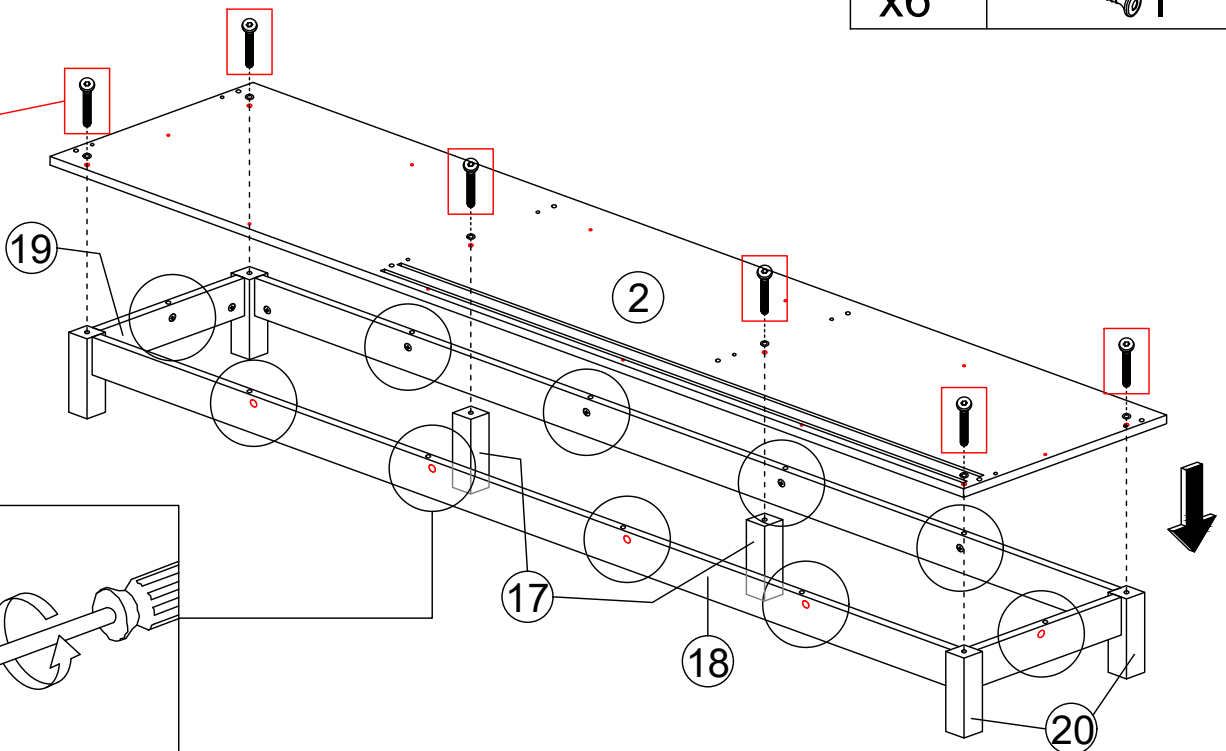
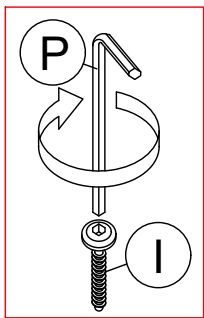

# ASSEMBLY INSTRUCTION

## Step 15

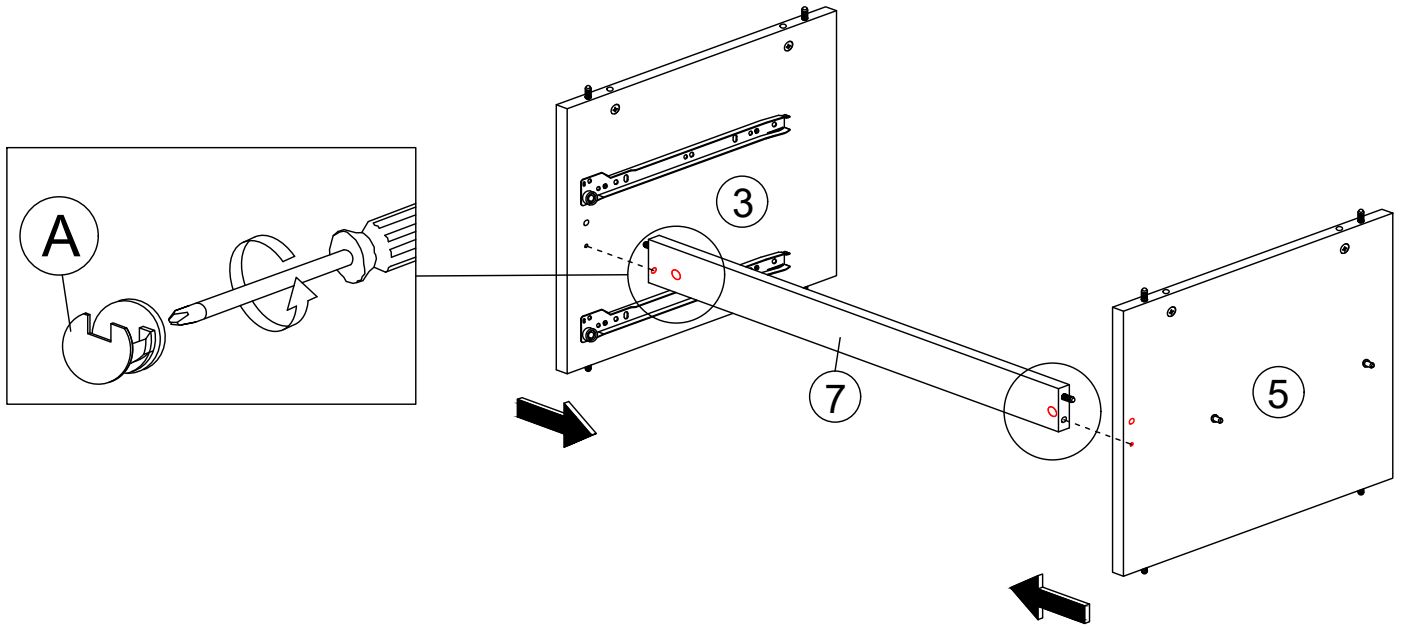
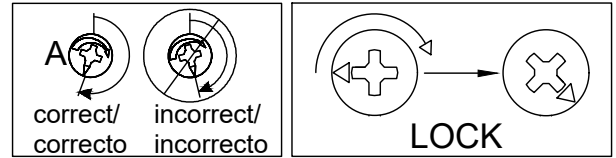

## Step 16

Required/Requis/Requerido

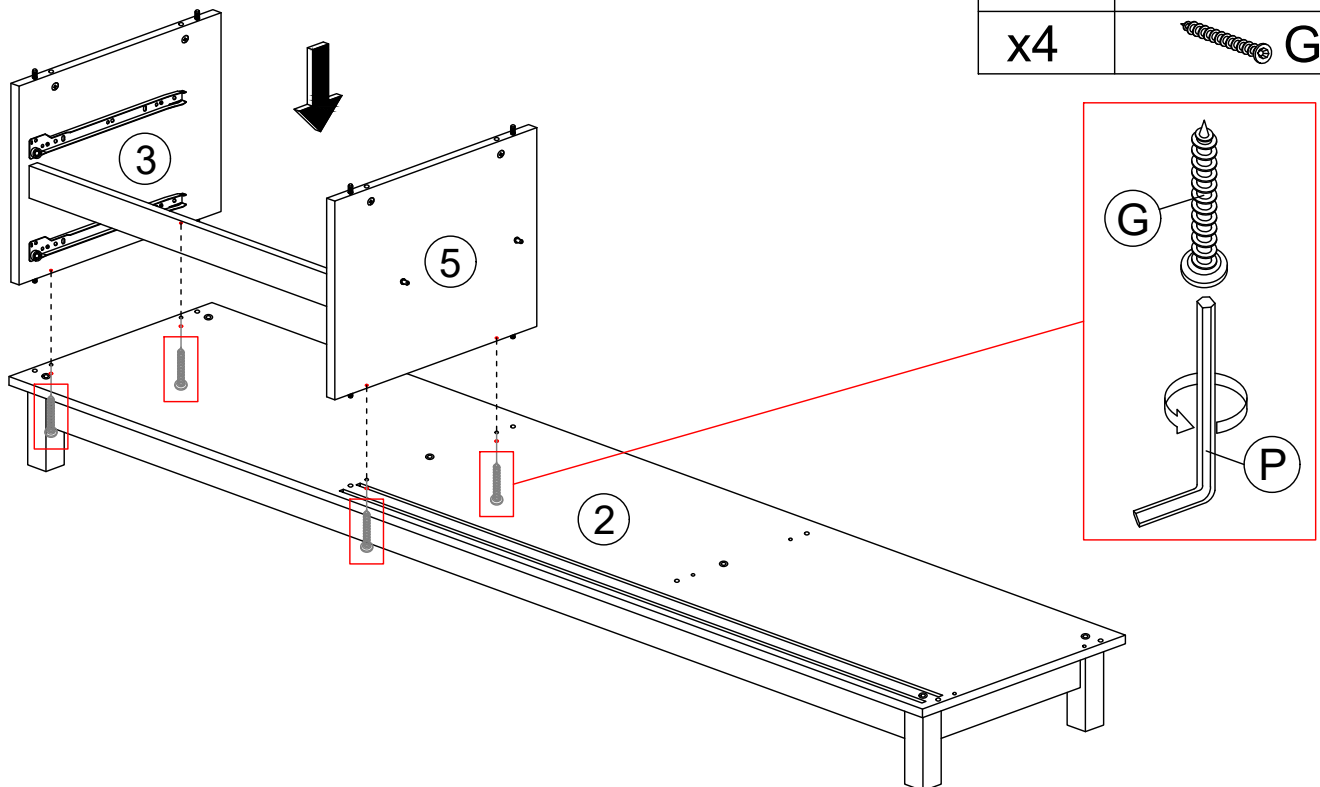

x1	P
x4	G



# ASSEMBLY INSTRUCTION

## Step 17

Required/Requis/Requerido

x1	 P
x4	 G

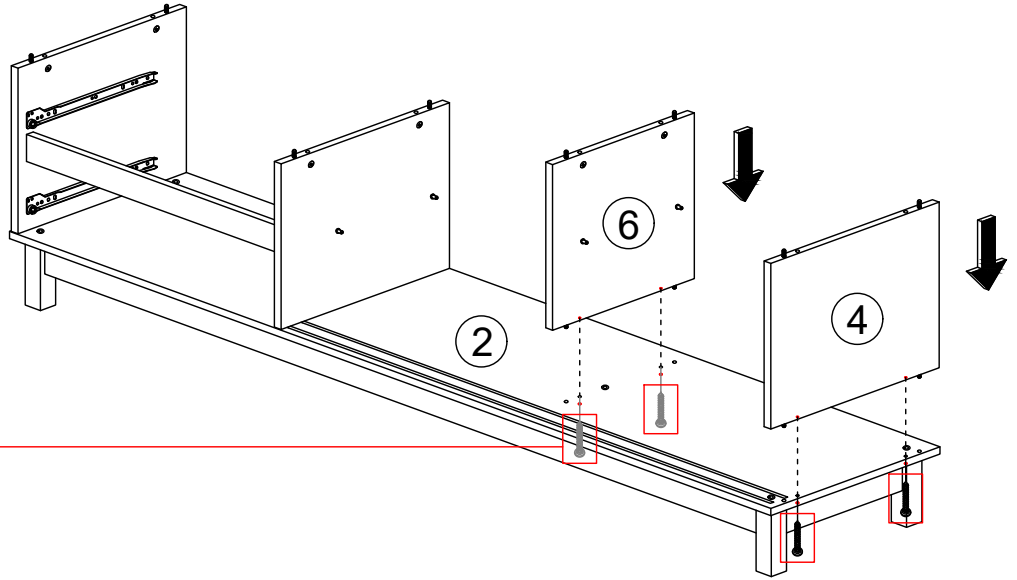
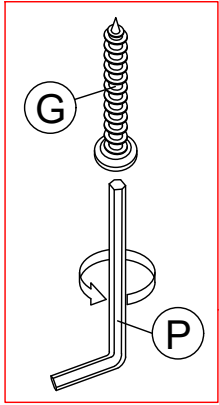

## Step 18

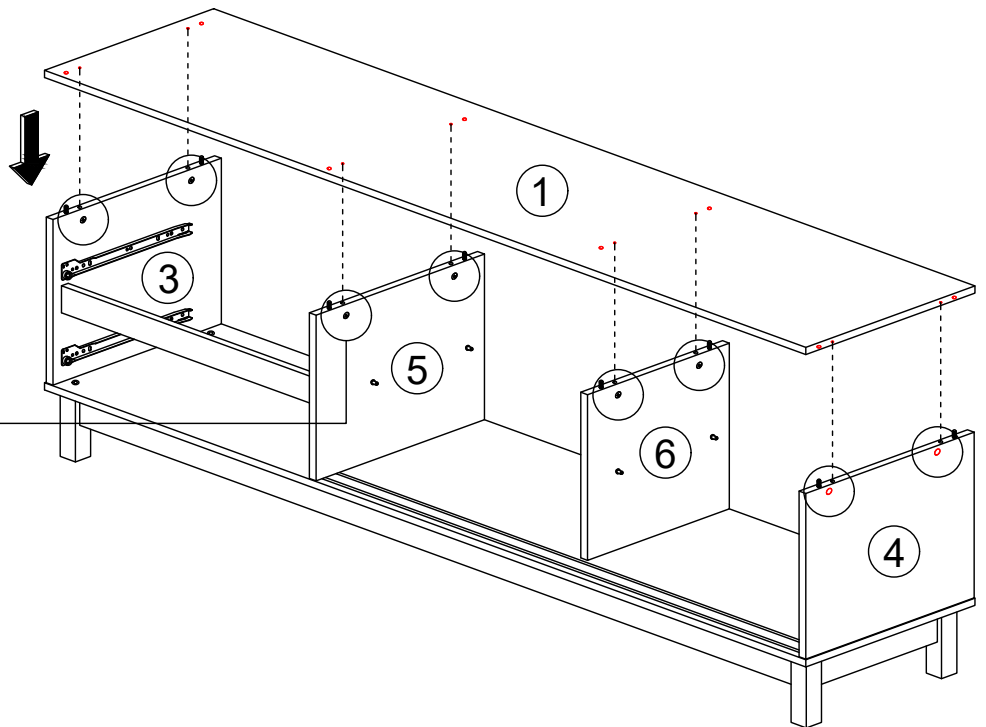
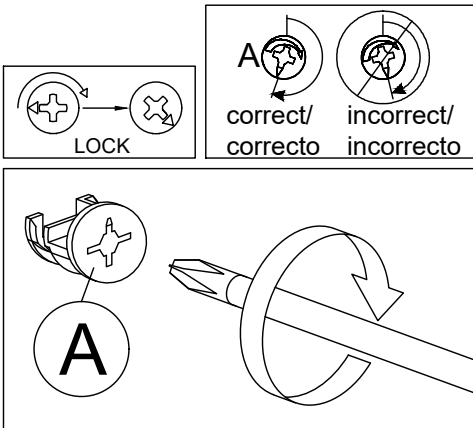

# ASSEMBLY INSTRUCTION

## Step 19

Required/Requis/Requerido

x25

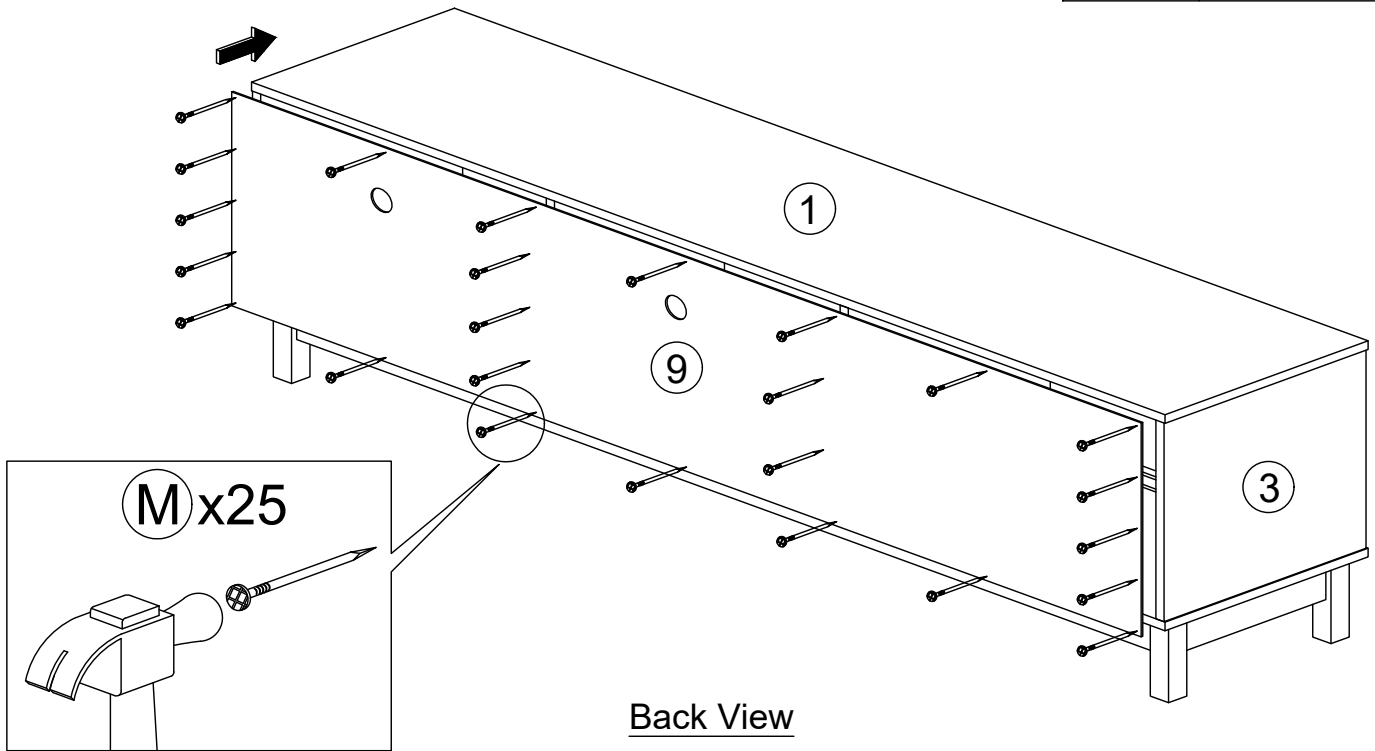
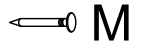

## Step 20

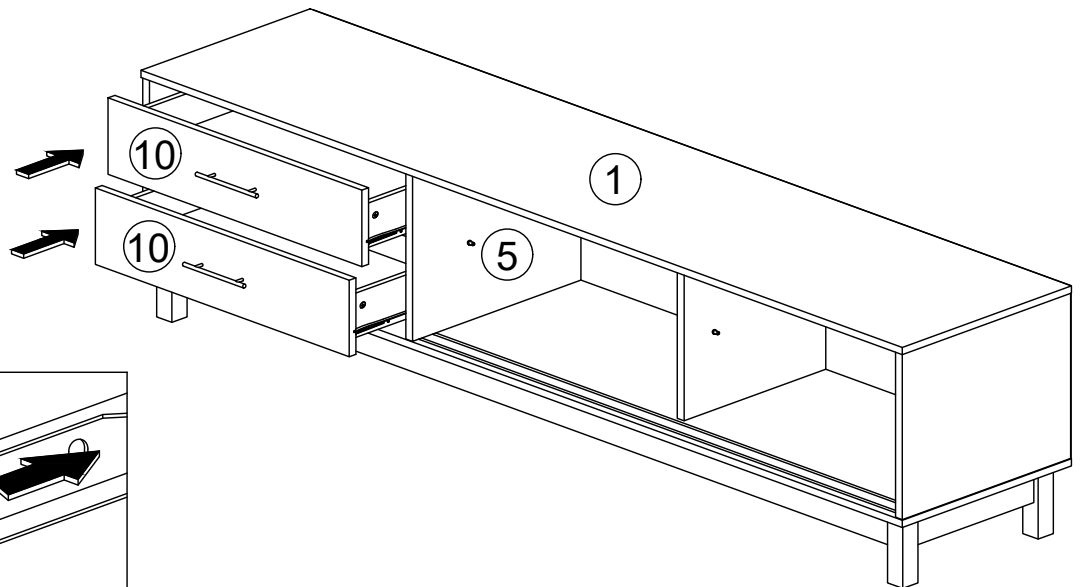

# ASSEMBLY INSTRUCTION

## Step 21

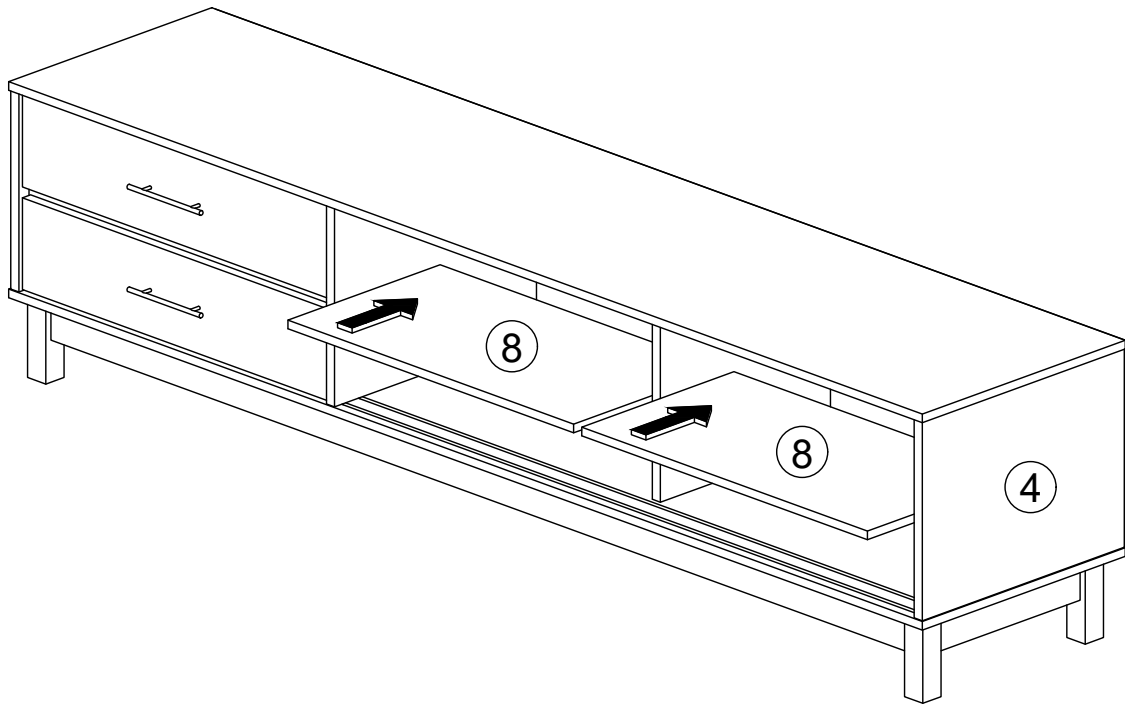

## Step 22

Required/Requis/Requerido

x16  E

x4  H1

x4  H2

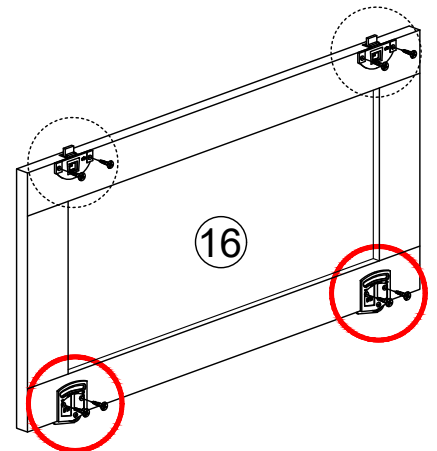
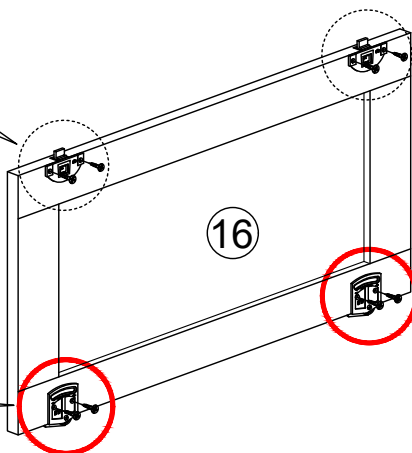
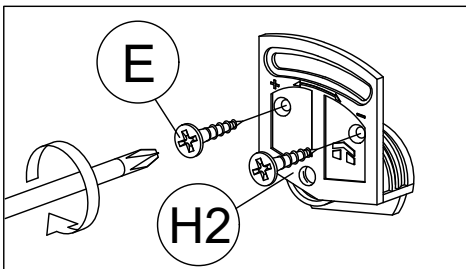
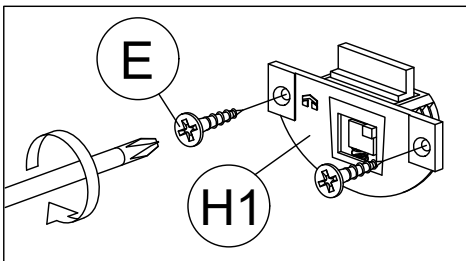

# ASSEMBLY INSTRUCTION

## Step 23

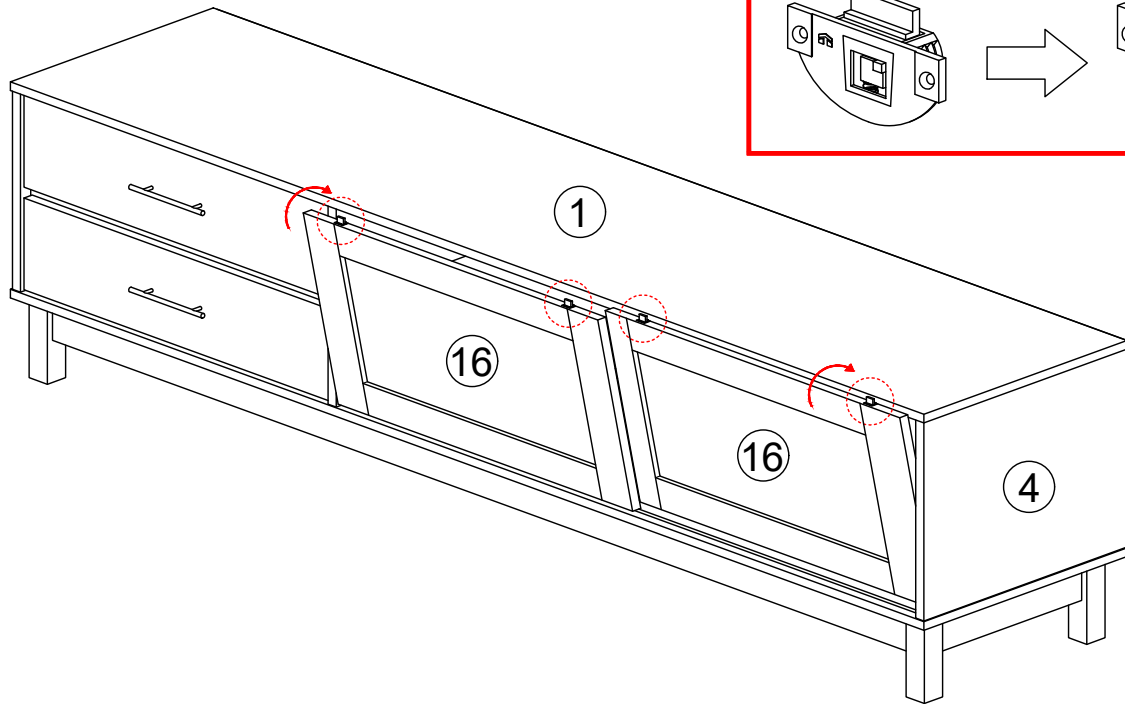

## Completed

