

3525CHES

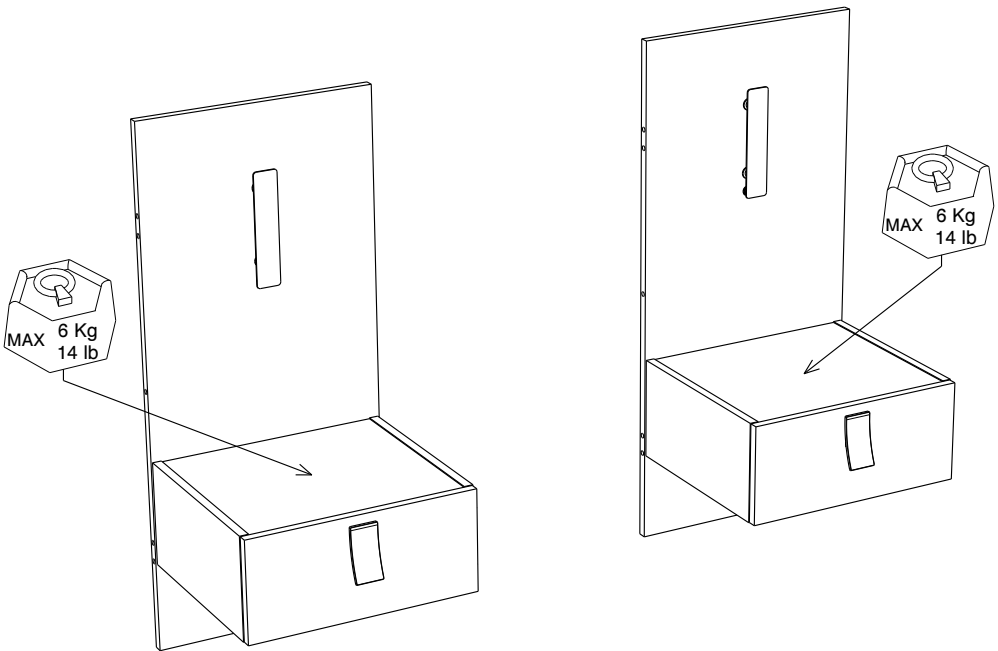

Gamme : KIERAN



PARISOT INDUSTRIE

FR Remerciements :

Nous vous remercions d'avoir choisi un meuble créé et fabriqué par le Groupe Parisot et espérons qu'il vous donnera entière satisfaction.

EN Thanks:

Thank you for choosing furniture designed and manufactured by the Parisot Group. We hope you are totally satisfied with your purchase.

DE Danksagung:

Wir danken Ihnen für den Kauf eines Frankreich von der Parisot-Gruppe entworfenen und hergestellten Möbelstücks und hoffen, dass Sie es zu Ihrer vollkommenen Zufriedenheit finden werden.

HU Köszönet:

Köszönjük, hogy a Parisot Groupe által létrehozott és gyártott bútort választott, reméljük, hogy elégedett lesz a termékkel.

PT Agradecimentos:

Obrigado por ter escolhido um móvel concebido e fabricado pelo Grupo Parisot, esperando que seja do seu inteiro agrado.

IT Ringraziamenti:

Grazie per avere scelto un mobile progettato e fabbricato dal Gruppo Parisot. Speriamo soddisfatti appieno le vostre esigenze.

NL Bedankje:

Wij bedanken u voor de aankoop van een door de Groep Parisot ontworpen en vervaardigd meubel en hopen dat u er veel plezier aan zult beleven.

CZ Poděkování:

Děkujeme, že jste si vybrali nábytek navržený a vyrobený společností Parisot Group. Doufáme, že budete svým nákupem naprosto spokojeni.

ES Agradecimientos:

Les damos las gracias por haber elegido un mueble diseñado y fabricado por el Groupe Parisot y esperamos que sea de su total agrado.

PL Podziękowania:

Dziękujemy za wybór mebli stworzonych i wyprodukowanych przez Grupę Parisot. Mamy nadzieję, że będziecie Państwo w pełni zadowoleni z zakupu.

SK Pod'akovanie:

Ďakujeme, že ste si vybrali nábytok navrhnutý a vyrobený spoločnosťou Parisot Group. Dúfame, že budete svojim nákupom absolútne spokojní.

AR شكر:

نشكركم لاختياركم هذه القطعة من الأثاث من تصميم وتصنيع مجموعة باريسو Parisot ونتمنى أن تنال رضاهكم.

PARISOT INDUSTRIE

15 Avenue Jacques Parisot, 70800 Saint-Loup sur Semouse
contact@parisot.com
RCS VESOUL 537 665 200

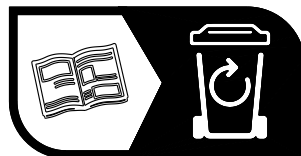
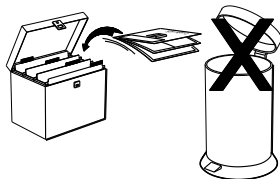

FR

Donnez ou recyclez
vos meubles.



Association



Magasin



Déchèterie

<https://quefairedemesdechets.fr>

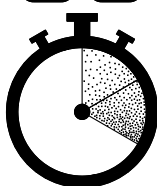
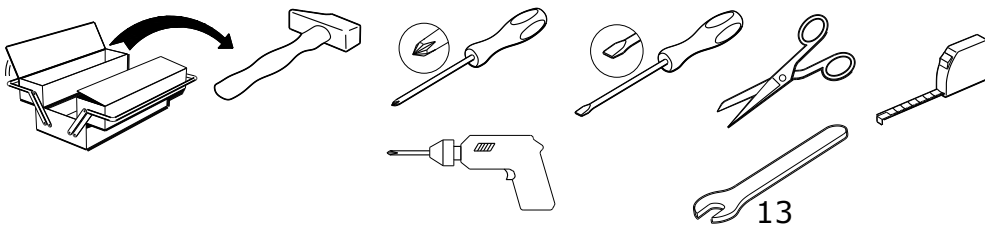

1h 45'

3h 30'

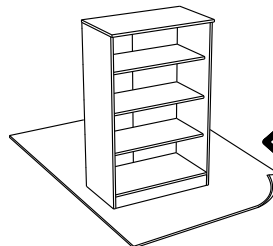
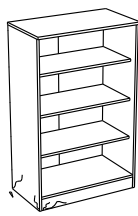

88.5cm
34 3/4"
40cm
15 3/4"
36cm
14 1/4"

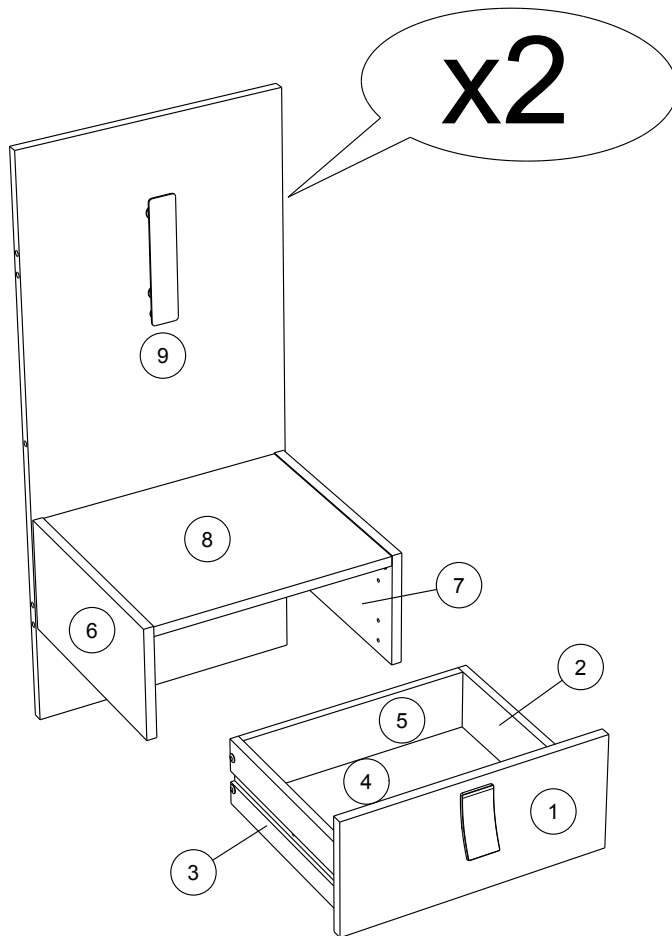

		mm			inch		
⑦	x 2	328	174	15	12 15/16	6 7/8	9/16
⑥	x 2	328	174	15	12 15/16	6 7/8	9/16
⑧	x 2	363	327	15	14 5/16	12 7/8	9/16
①	x 2	391	173	15	15 3/8	6 13/16	9/16
⑨	x 2	882	398	15	34 3/4	15 11/16	9/16
②	x 2	300	100	13	11 13/16	3 15/16	1/2
③	x 2	300	100	13	11 13/16	3 15/16	1/2
⑤	x 2	330	100	13	13	3 15/16	1/2
④	x 2	342	299	2	13 7/16	11 3/4	1/16

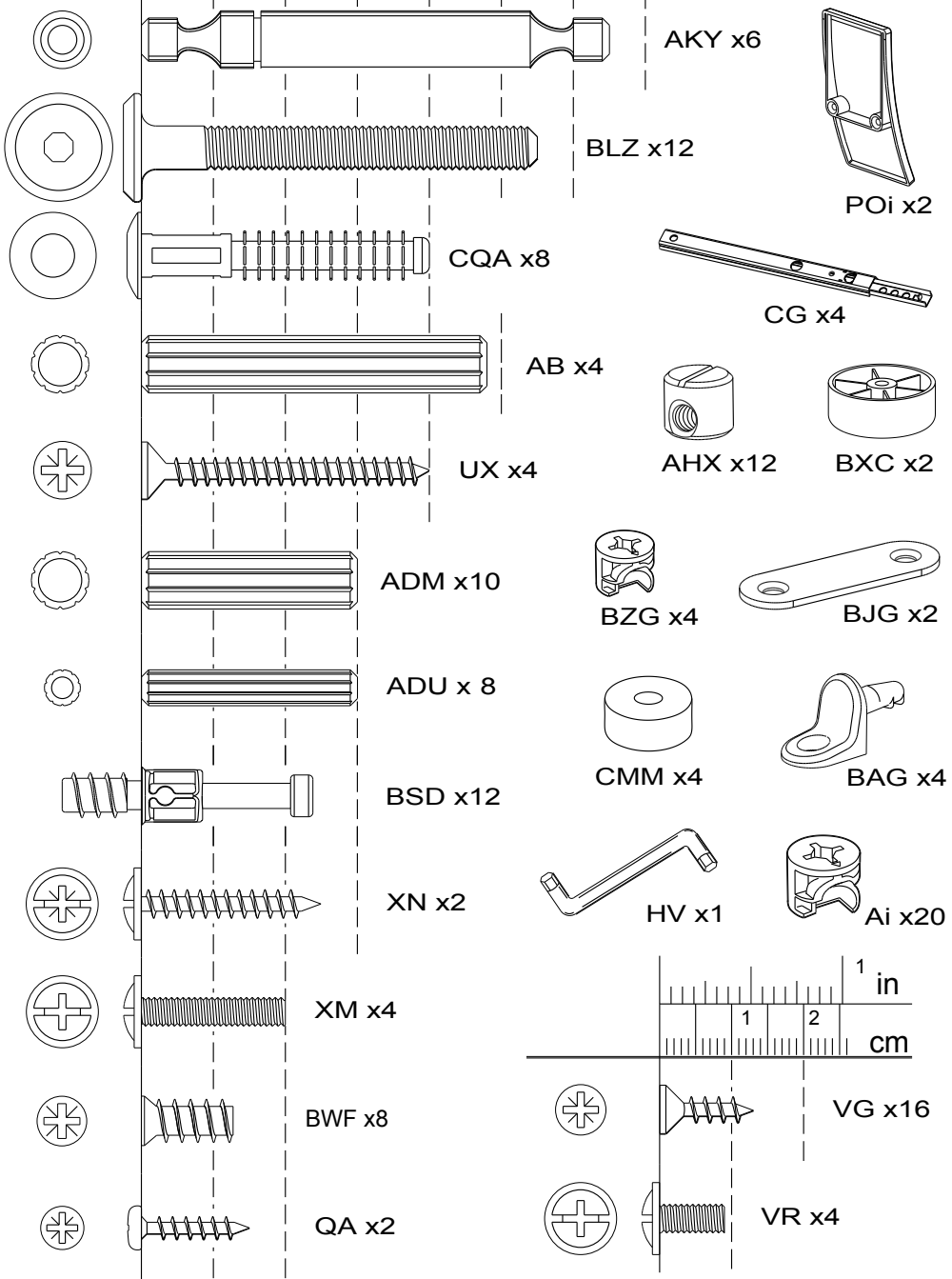
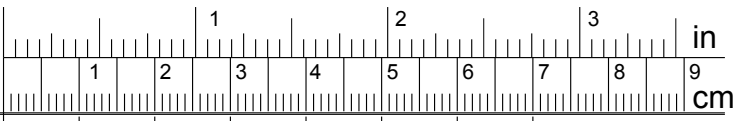

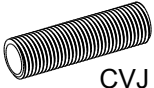
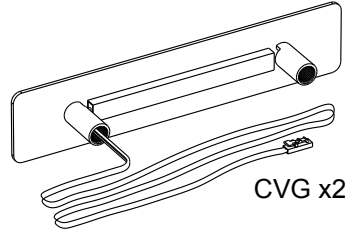
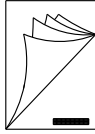
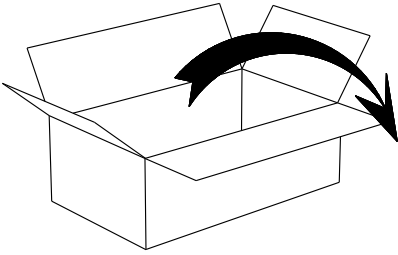

CVJ x4



CVM x4

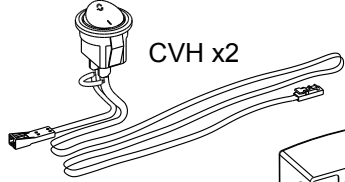

CVH x2



CVL x4

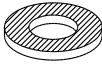

CVK x4

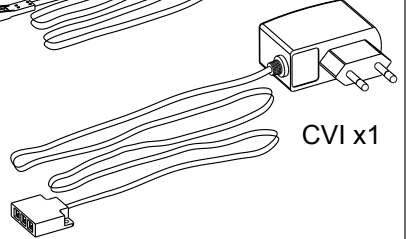

CVI x1

- FR: INSTRUCTIONS GÉNÉRALES POUR LE MOBILIER CONSTITUÉ DE BOIS OU DE COMPOSITES DE BOIS (COMME LES SURFACES EN MELAMINÉ, STRATIFIÉ OU PLACAGE)**
Nettoyer à l'aide d'un chiffon humide. Utiliser uniquement de l'eau ou un détergent doux.
Essuyer à l'aide d'un chiffon propre.
Pour une stabilité optimale, resserrer les vis et autres fixations lorsque nécessaire.
- EN: GENERAL INSTRUCTION FOR FURNITURE MADE OF WOOD OR WOOD COMPOSITES SUCH AS MELAMINE, LAMINATE OR VENEER SURFACES**
Wipe clean with a damp cloth. Use only water or a gentle detergent.
Wipe dry with a clean cloth.
For increased stability, re-tighten the screws and other connectors when necessary.
- DE: ALLGEMEINE ANWEISUNGEN FÜR MÖBELPFLEGE AUS HOLZ ODER HOLZVERBUNDWERKSTOFFEN (WIE MELAMIN-, LAMINA T- ODER FURNIEROBERFLÄCHEN)**
Mit einem feuchten Tuch reinigen. Verwenden Sie nur Wasser oder ein mildes Reinigungsmittel.
Mit einem sauberen Tuch abwischen.
Zur Erhöhung der Stabilität die Schrauben und anderen Verbindungsstücke bei Bedarf nachziehen.
- HU: ÁLTALÁNOS ÚTMUTATÁS A FÁBÓL KÉSZÜLT VAGY ÖSSZETETT FAANYAGOT, PÉLDÁUL MELAMIN-, LAMINÁLT VAGY FURNÉRFELÜLETET TARTALMAZÓ BÚTOROKHOZ**
Törölje tisztára nedves ruhával. Csak vizet vagy kímélő tisztítószerrel használjon.
Törölje szárazra tiszta ruhával.
A nagyobb stabilitás érdekében szükség esetén húzd meg újra a csavarokat és egyéb összekötő elemeket.
- PT: INSTRUÇÕES GERAIS PARA OS MOVÉIS DE MADEIRA, LAMINADO, MELAMINA E FOLHEADO.**
Limpar com um pano húmido, utilizar apenas água ou detergente doce.
Limpar com um pano seco.
Para uma maior estabilidade, volte a apertar os parafusos e outros conetores sempre que necessário.
- IT: ISTRUZIONI GENERALI PER MOBILI IN LEGNO O MATERIALI COMPOSITI IN LEGNO (COME SUPERFICIE IN MELAMINICO, LAMINATO O IMPIALLACCIATO)**
Pulire con un panno umido. Utilizzare solo acqua o un detergente delicato.
Asciugare con un panno pulito.
Per una maggiore stabilità, stringi nuovamente le viti e gli altri elementi di fissaggio quando necessario.
- NL: ALGEMENE INSTRUCTIES VOOR MEUBELS VERVAARDIGD UIT HOUT OF HOUTCOMPOSITET ALS MELAMINE, LAMINAAT OF FINEEROPPERVLAKKEN!**
Reinig met een vochtige doek. Gebruik alleen water of wasmiddel.
Droogwrijven met een schone doek.
Voor extra stevigheid te schroeven en andere verbindingen nogmaals aandraaien wanneer nodig.
- CZ: OBEČNÉ POKYNY TÝKAJÍCÍ SE NÁBYTKU VYROBENÉHO ZE DŘEVA NEBO Z KOMPOZITŮ DŘEVA, NAPŘ. S POUŽITÍM MELAMINU, LAMINÁTU NEBO DÝHY!**
Čistíte ořtením navlhčeným hadříkem. Používejte pouze vodu nebo jemný čistící prostředek.
Vyřtíte dosucha čistým hadříkem.
Pro zvýšení stability šrouby a další spojovací díly v případě potřeby dotáhněte.
- ES: INSTRUCCIONES GENERALES PARA MUEBLES FABRICADOS CON MADERA, MELAMINA, LAMINADO Y CHAPA.**
Limpiar con pano húmedo. Utilizar únicamente agua o detergente suave.
Secar con un paño seco.
Para mayor estabilidad, aprieta de nuevo los tornillos y otros conectores cuando sea necesario.
- PL: OGÓLNE INSTRUKCJE DOTYCZĄCE MEBLI Z DREWNA ORAZ MATERIAŁÓW DREWNOPOCHODNYCH: MELAMINA, LAMINAT, OKLEINA**
Do czyszczenia należy używać wilgotnej ściereczki. Używać wyłącznie wody lub delikatnego detergentu.
Wycierać do sucha ściereczką.
Aby uzyskać optymalną stabilność, w razie potrzeby dokręć śruby i inne elementy mocujące.
- SK: VŠEOBECNÉ POKYNY PRE NÁBYTOK VYROBENÝ Z DREVA ALEBO KOMPOZITNÝCH MATERIÁLOV, NAPRIKLAD MELAMINU, LAMINÁTU ALEBO PREGLEJKOVÝCH POVRCHOV!**
Utrite dočista navlhčenou utierkou. Používajte iba vodu alebo jemný čistiaci prostriedok.
Utrite dosucha čistou utierkou.
Na zvýšenie stability v prípade potreby opätovne utiahnite skrutky a ostatné spojovacie prvky.
- AR: تعليمات عامة للأثاث المصنوع من الخشب أو الخشب المركبات مثل الميلامين أو الصفيح أو الأسطح الخشبية**
امسحى بقطعة قماش مبللة. استخدم الماء أو المنظف اللطيف فقط. يجف بقطعة قماش نظيفة.
لمزيد من الثبات، أعد ربط المسامير والوصلات الأخرى عند الضرورة.

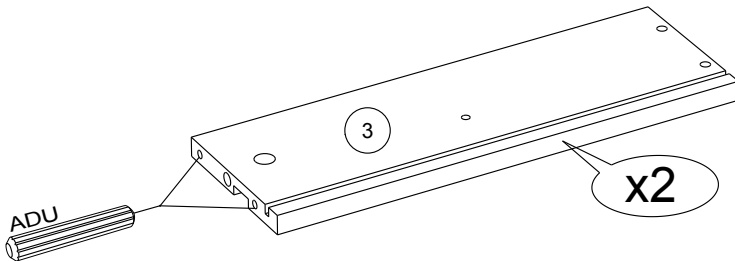
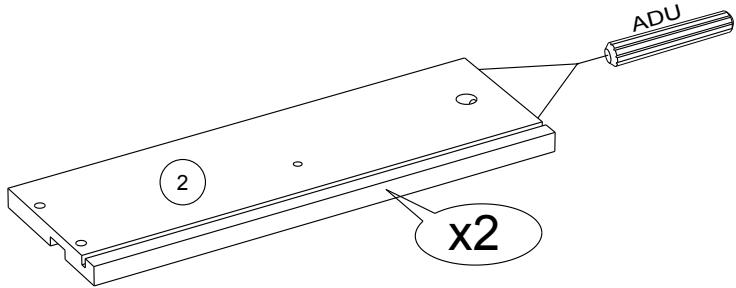
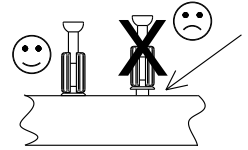
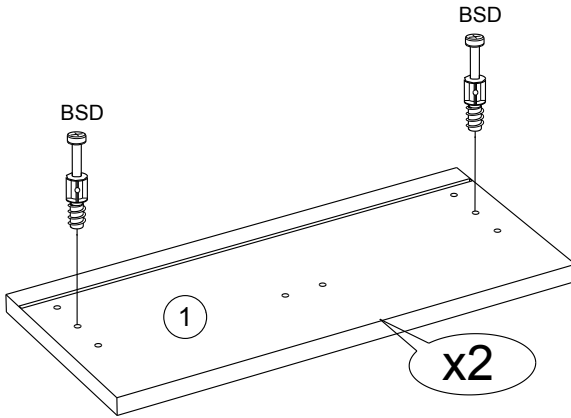
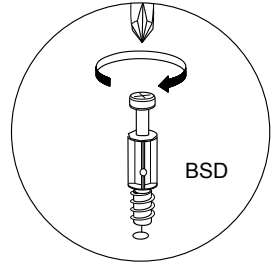
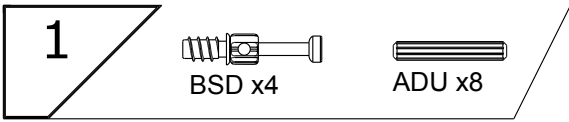

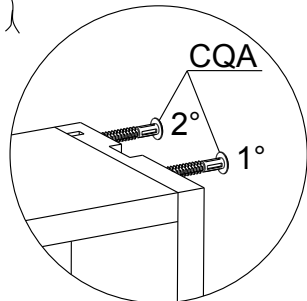
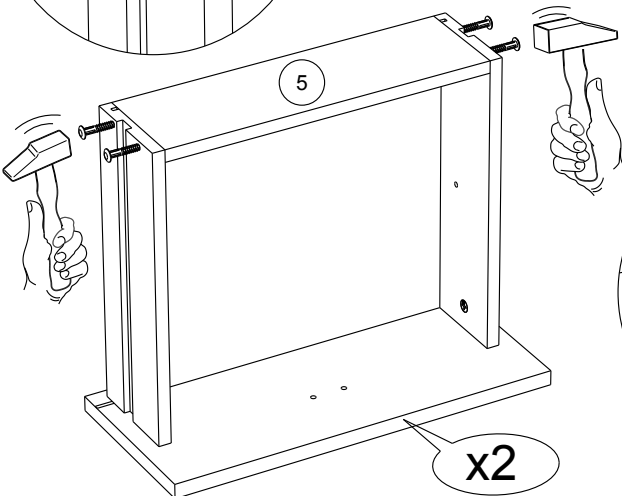
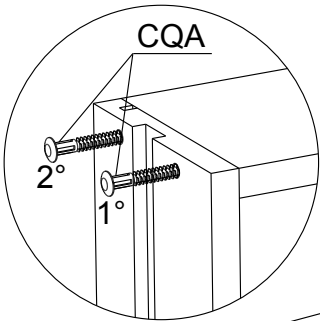
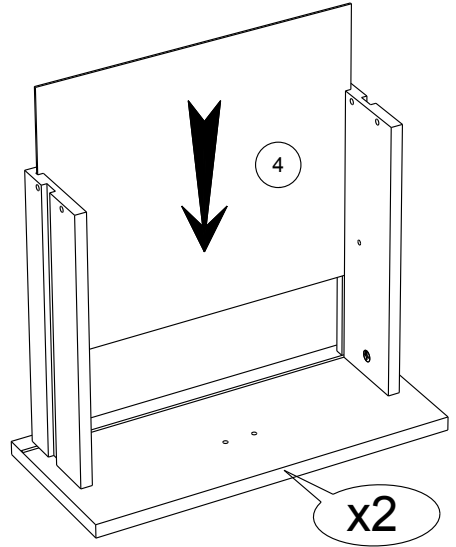
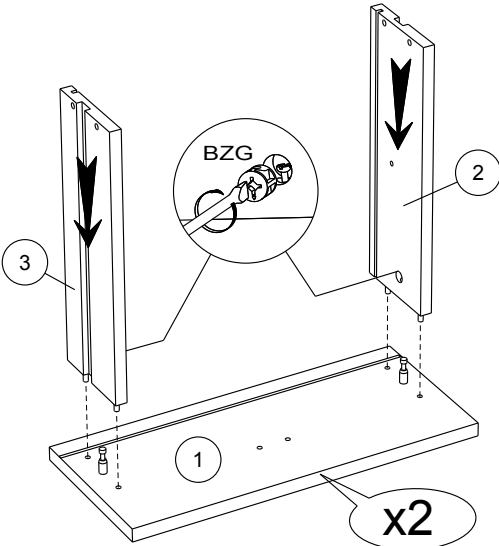
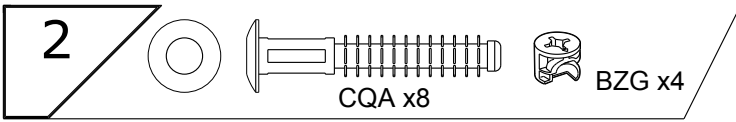

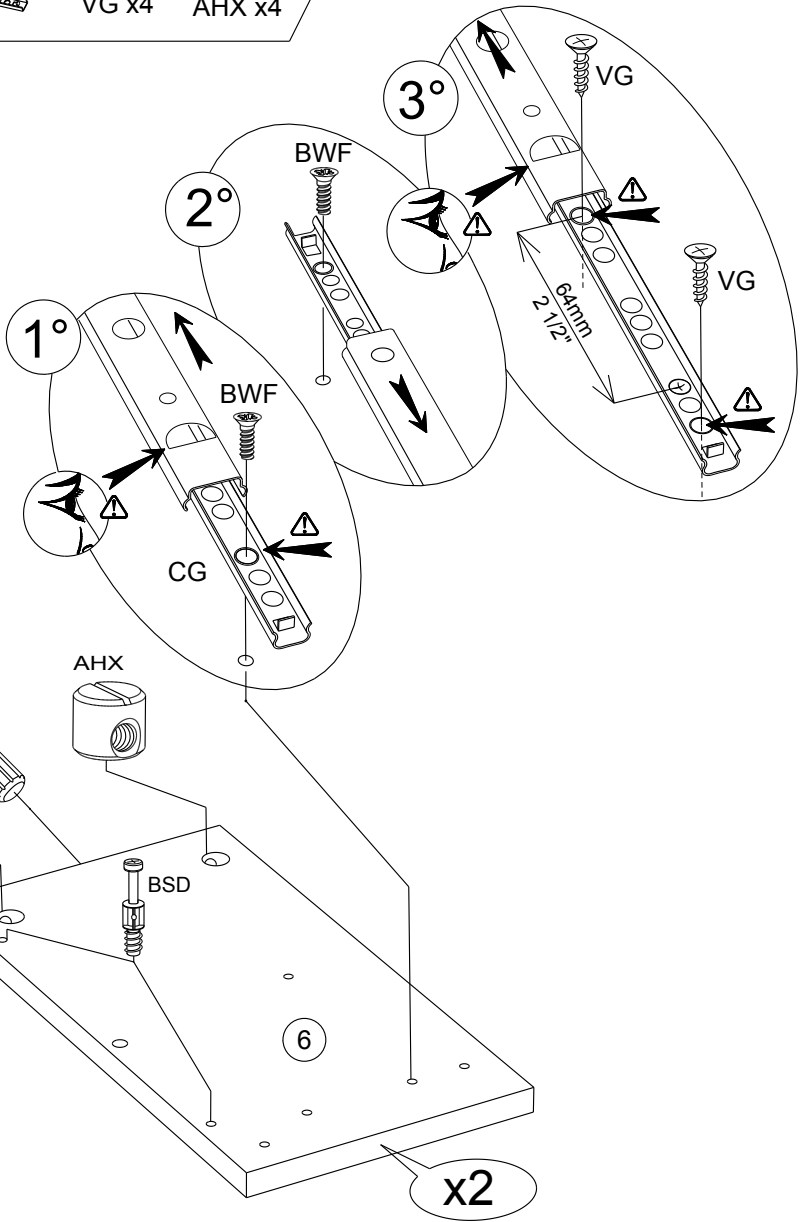
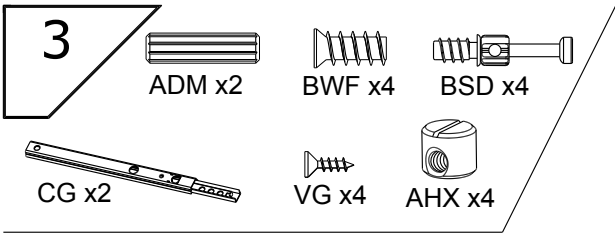

4



ADM x2



BWF x4

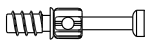

BSD x4

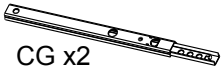

CG x2



VG x4



AHX x4

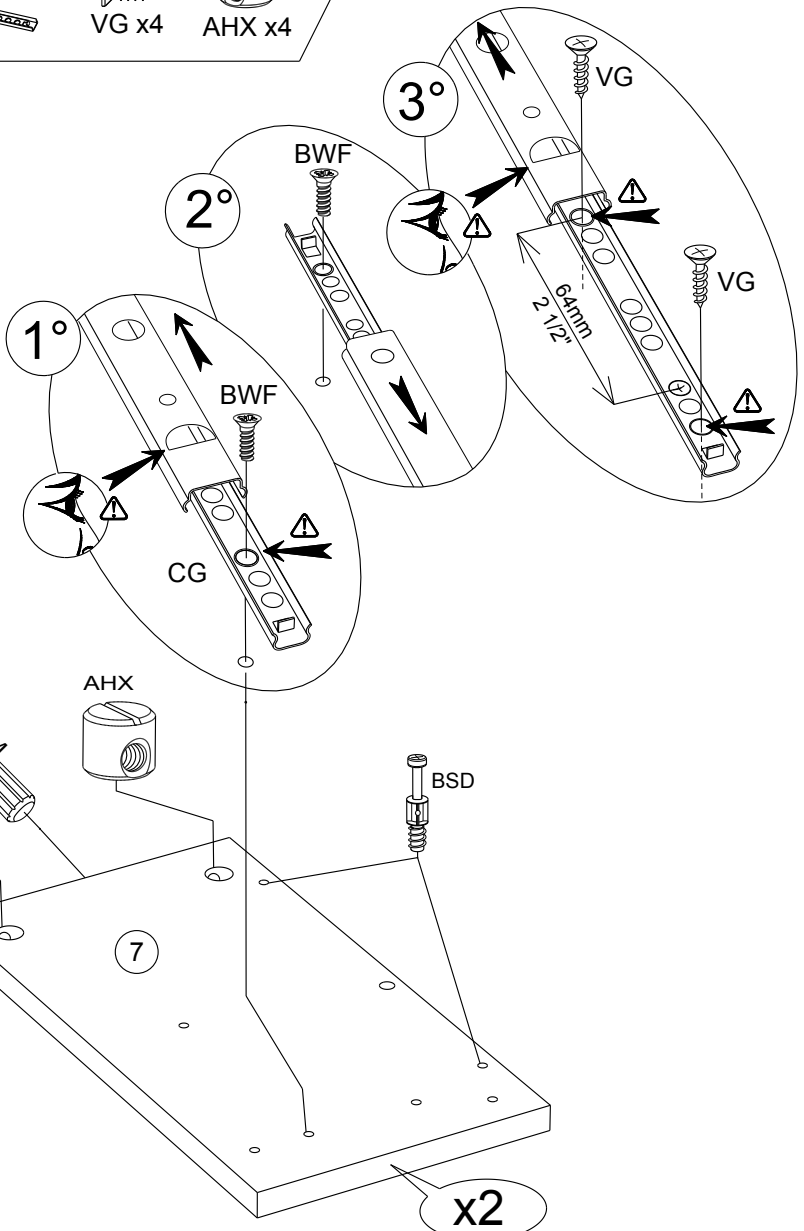

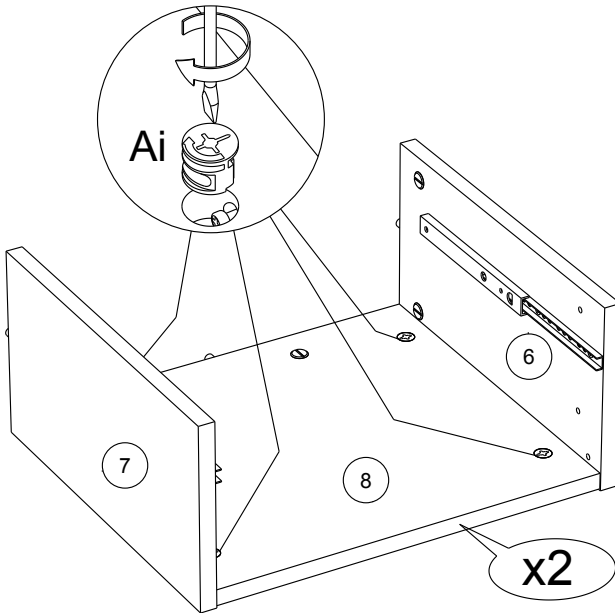
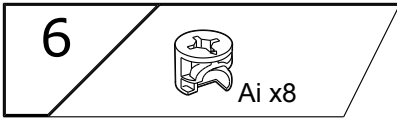
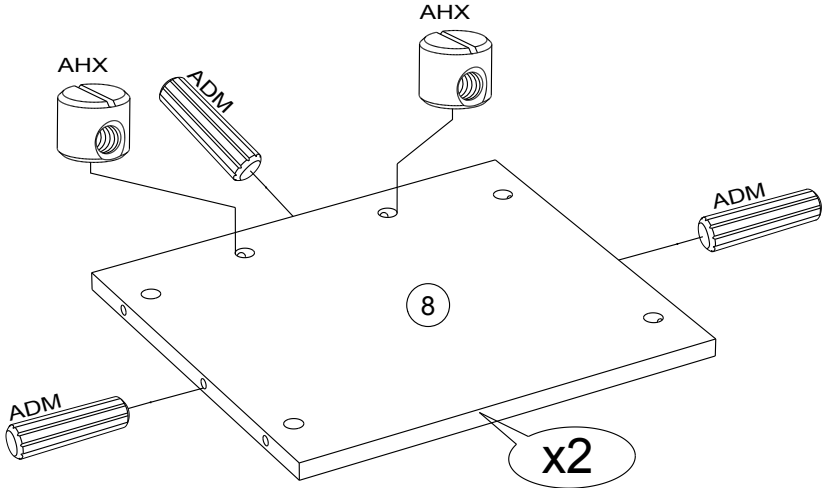
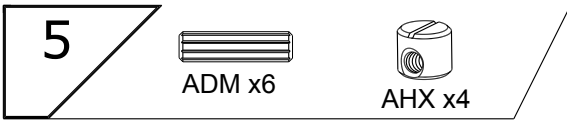

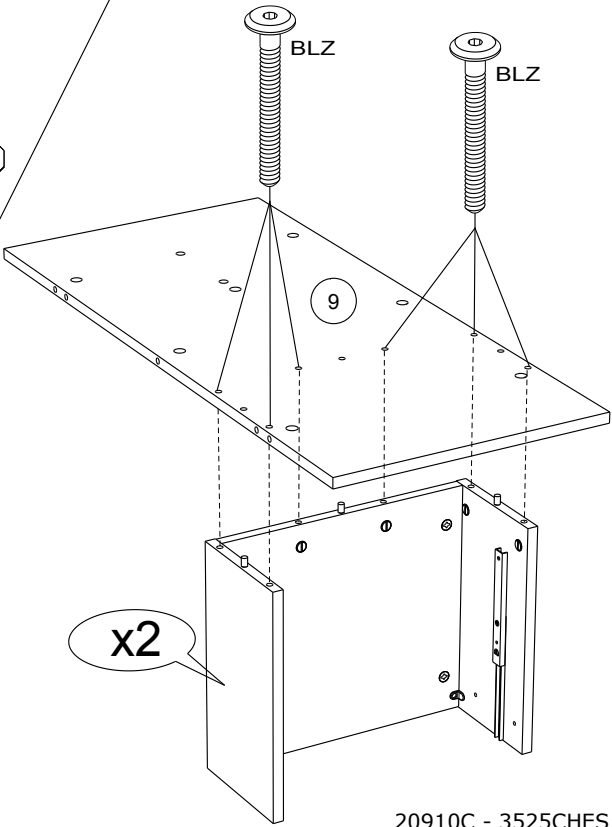
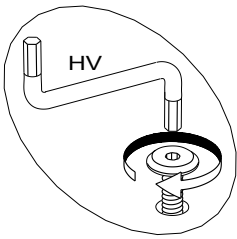
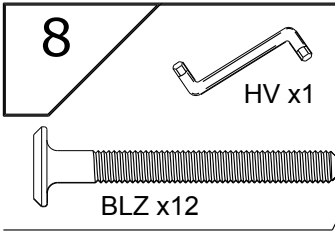
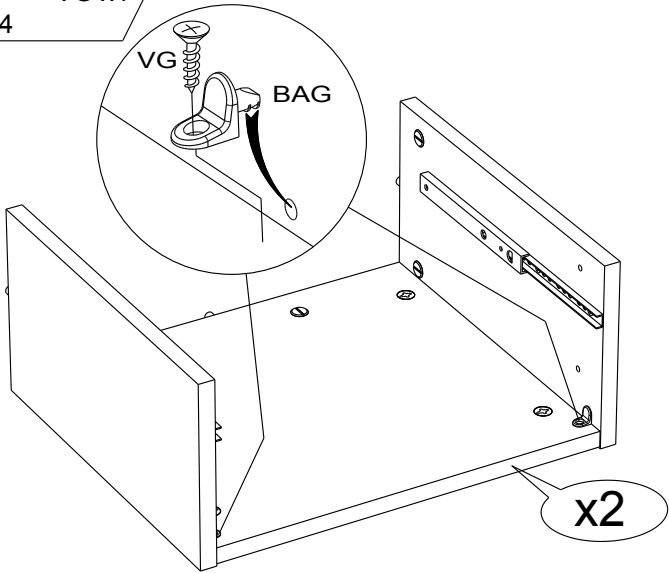

10

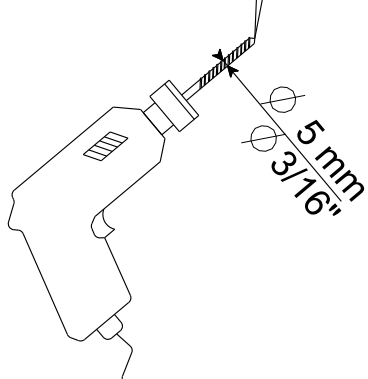
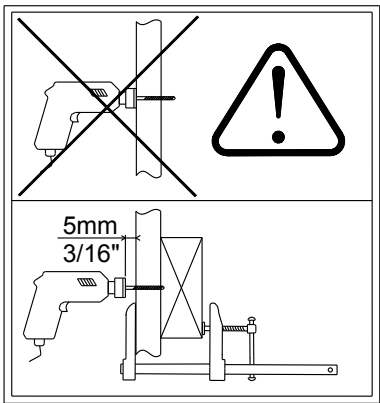
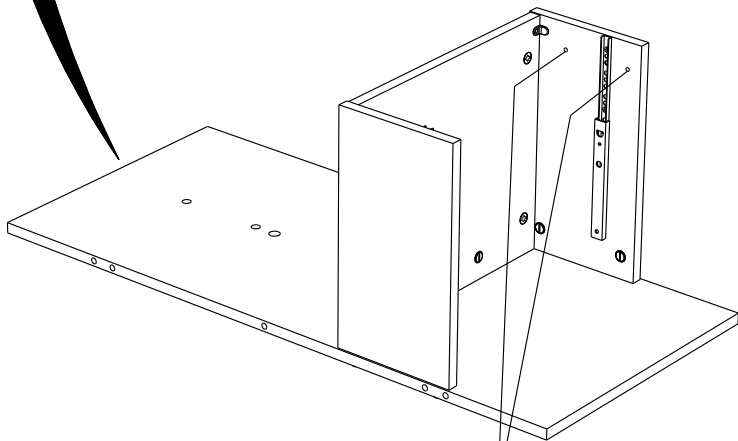
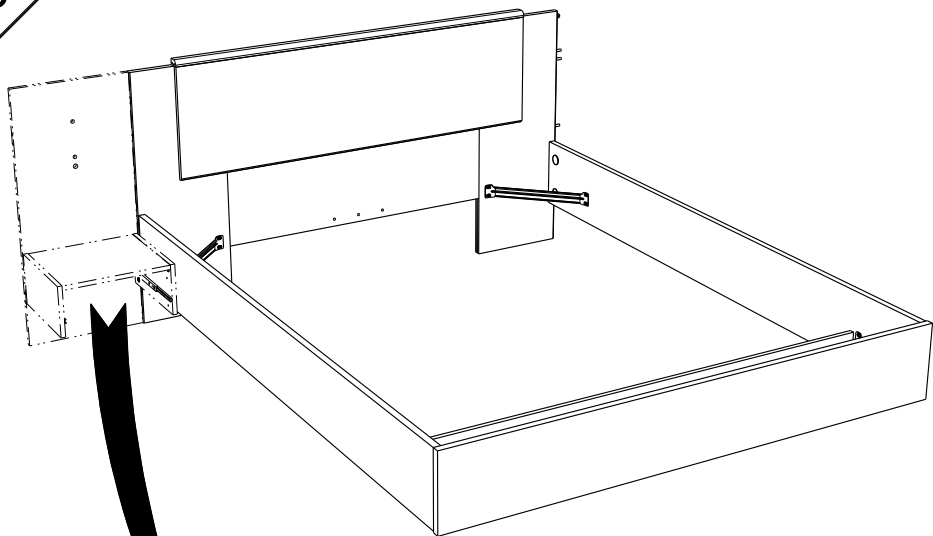

11

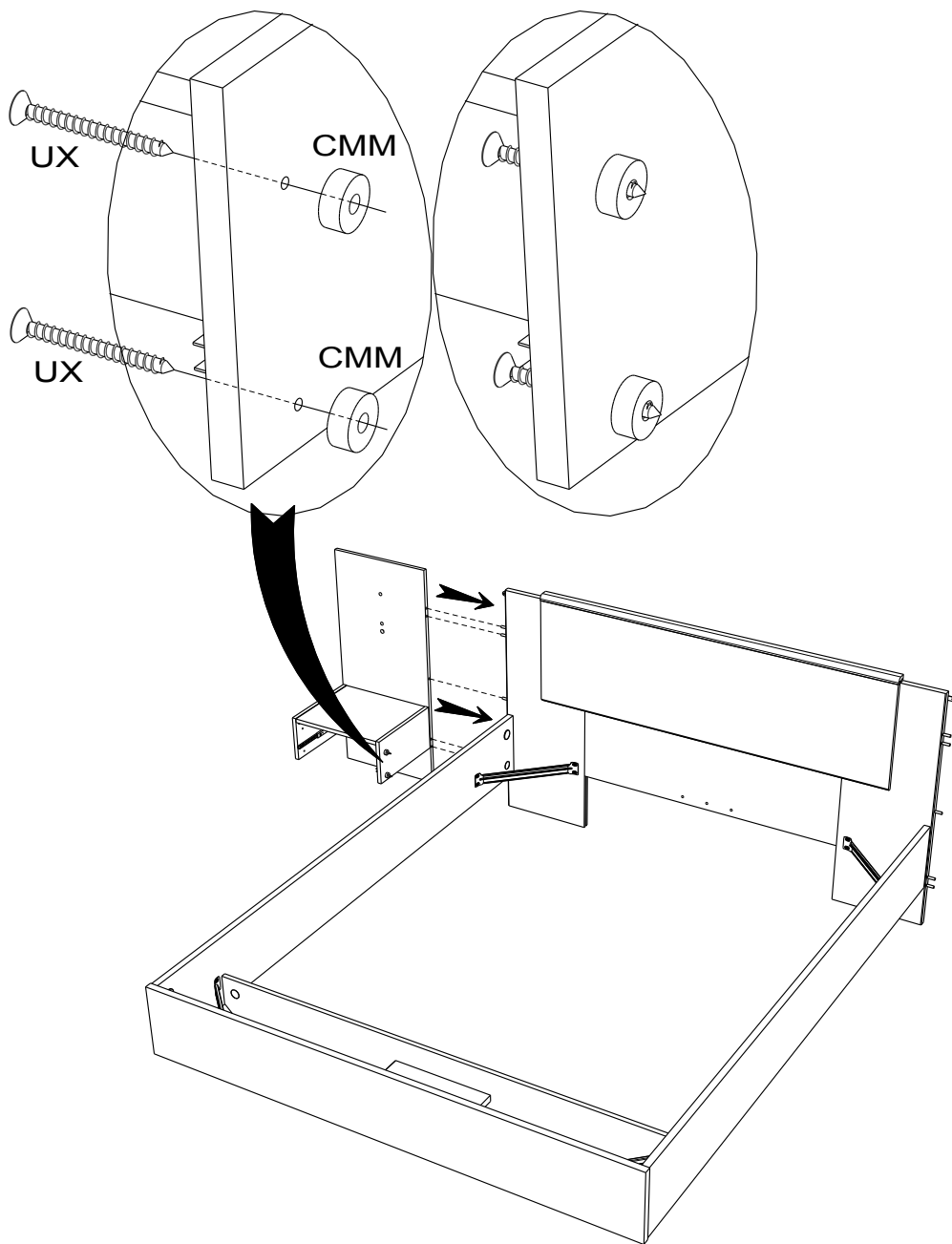

12



Ai x3



VG x1

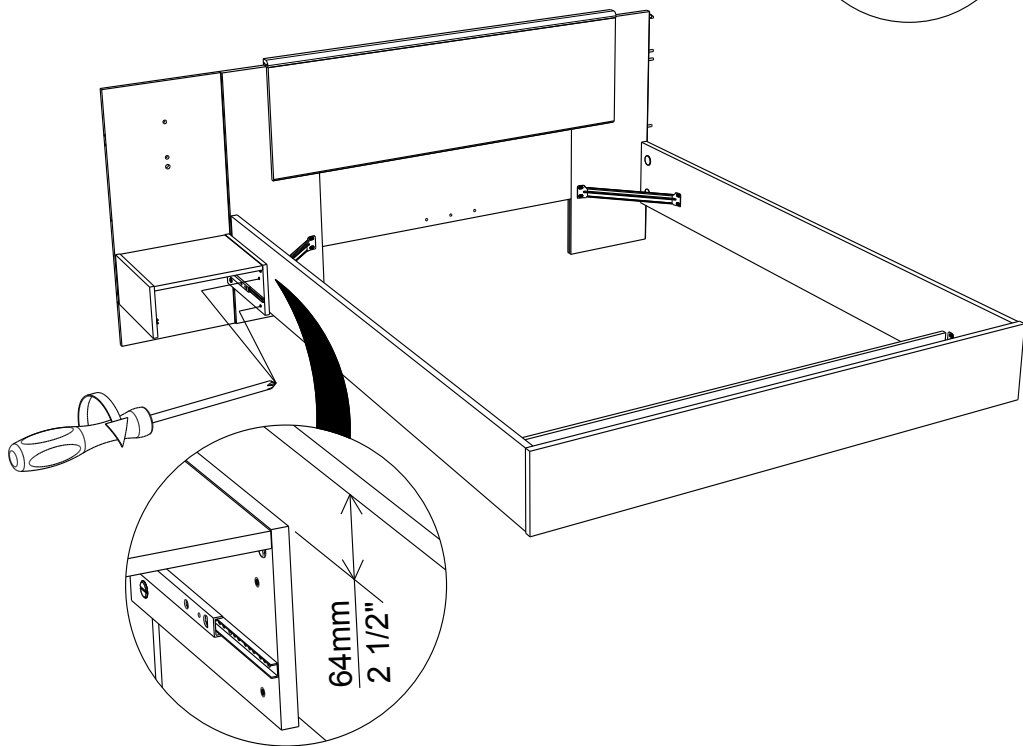
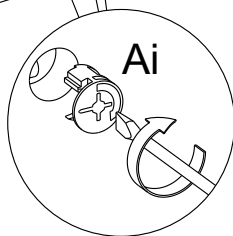
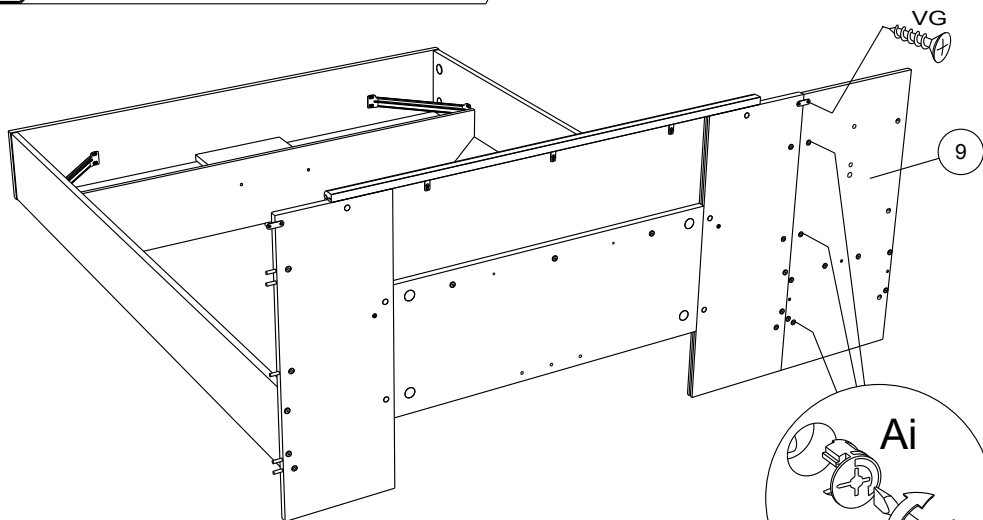

13

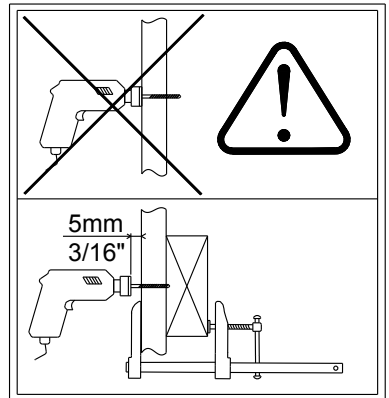
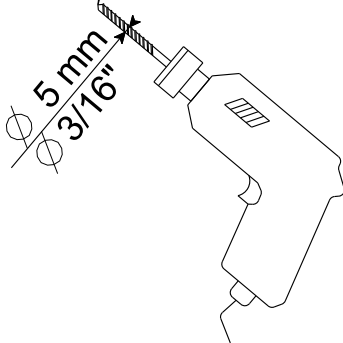
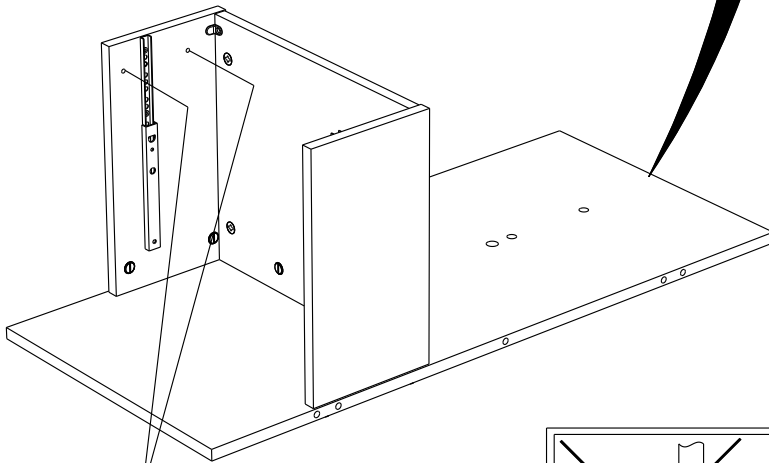
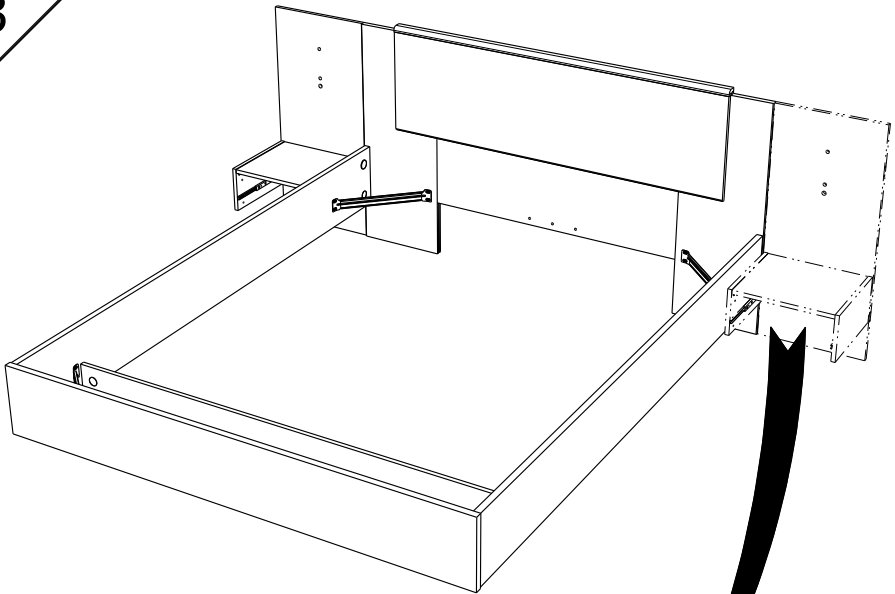

14

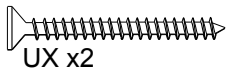

UX x2



CMM x2

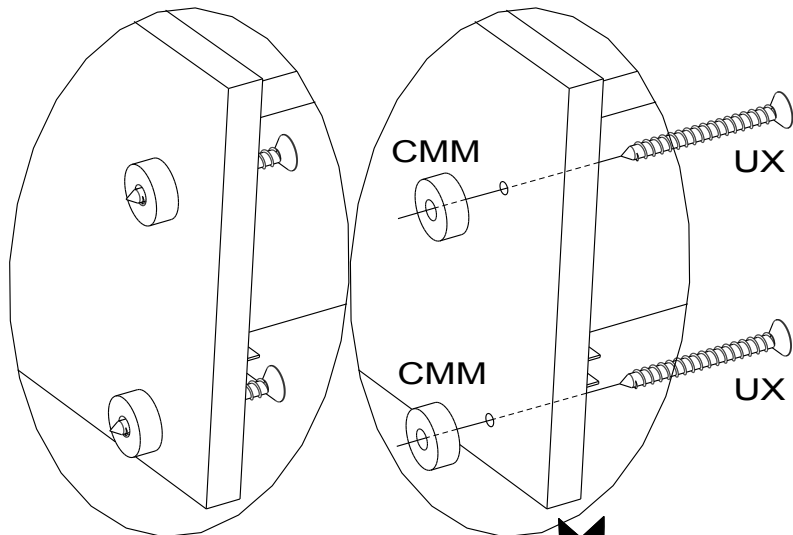

CMM

UX

CMM

UX

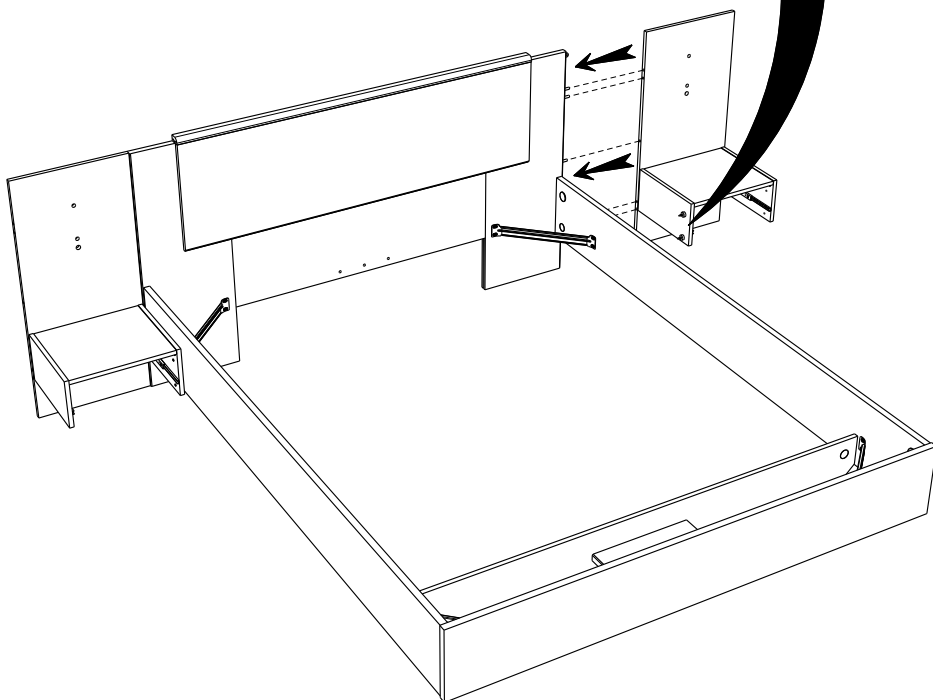

15



Ai x3



VG x1

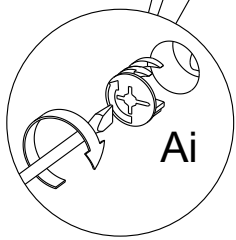
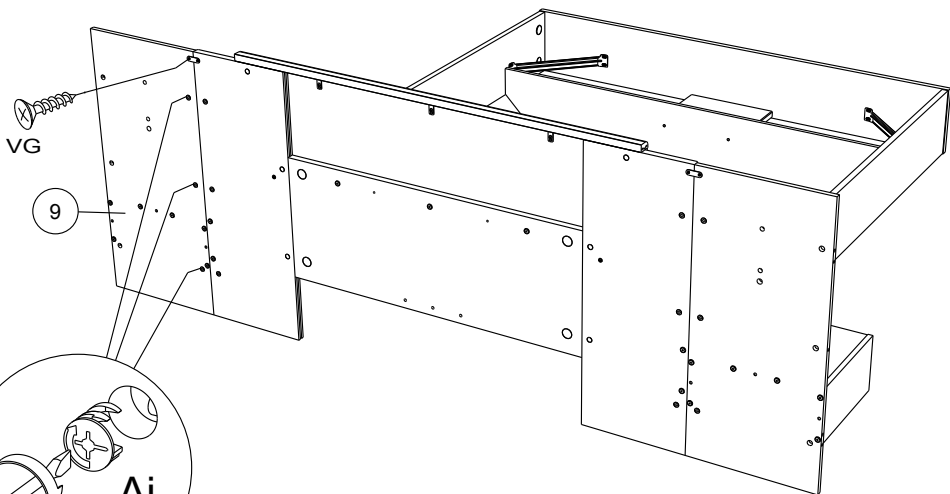

Ai

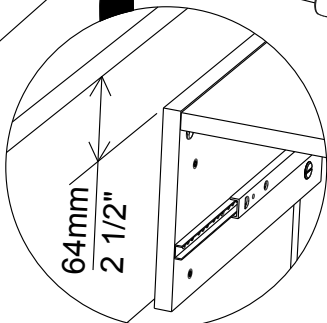
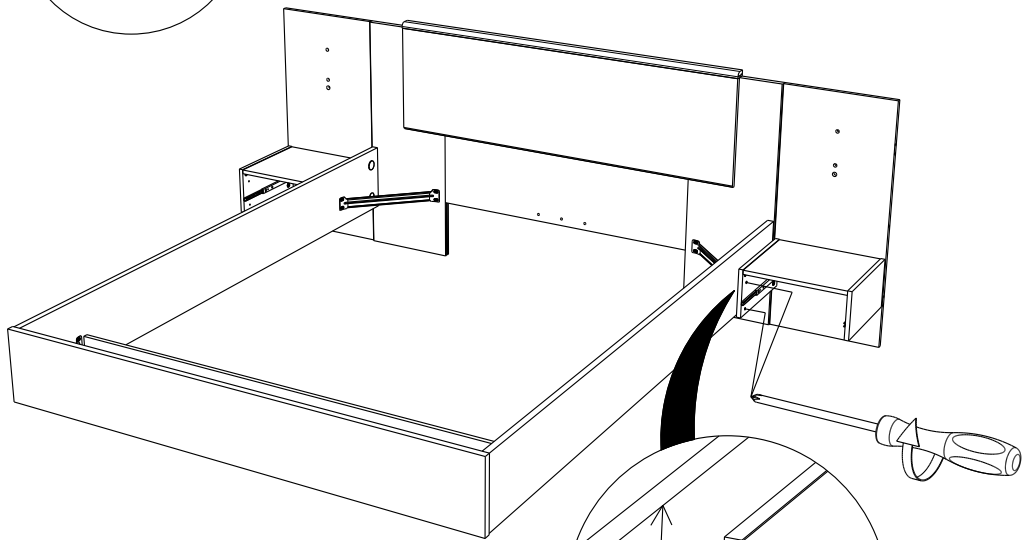

64mm
2 1/2"

16



AB x4

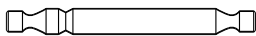

AKY x6



Ai x6

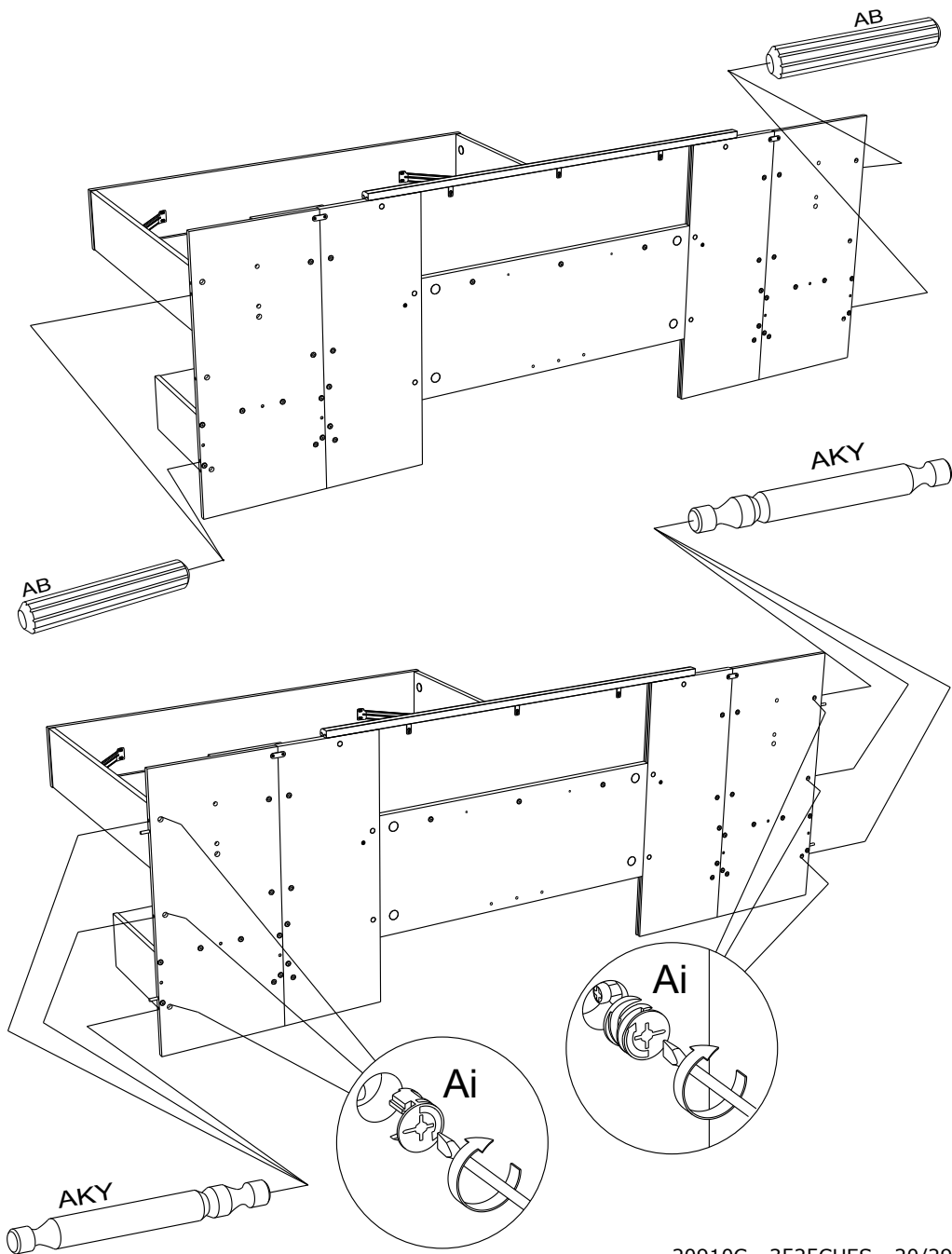

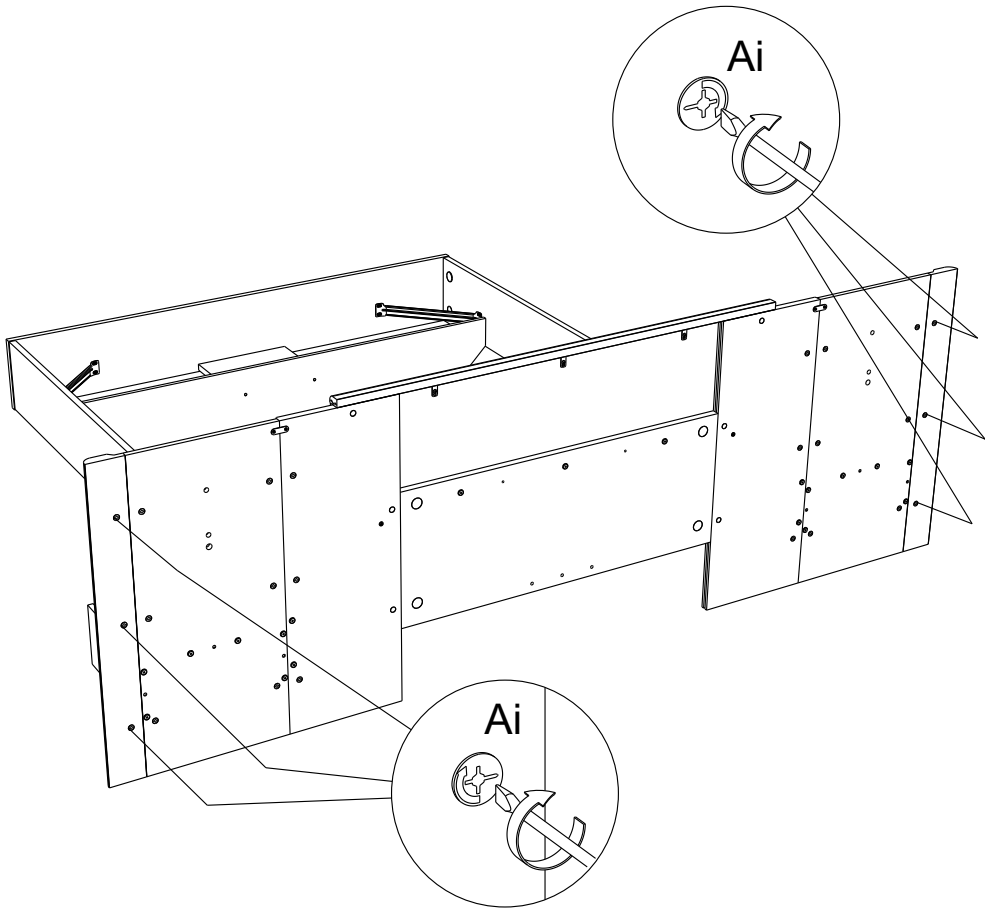

18



BJG x2



VG x4

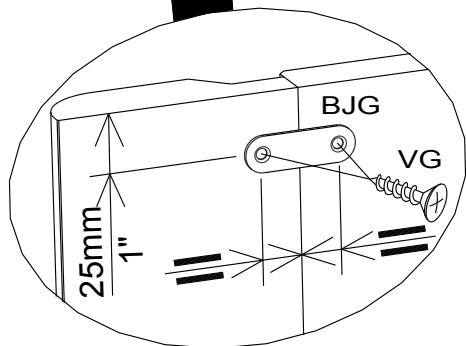
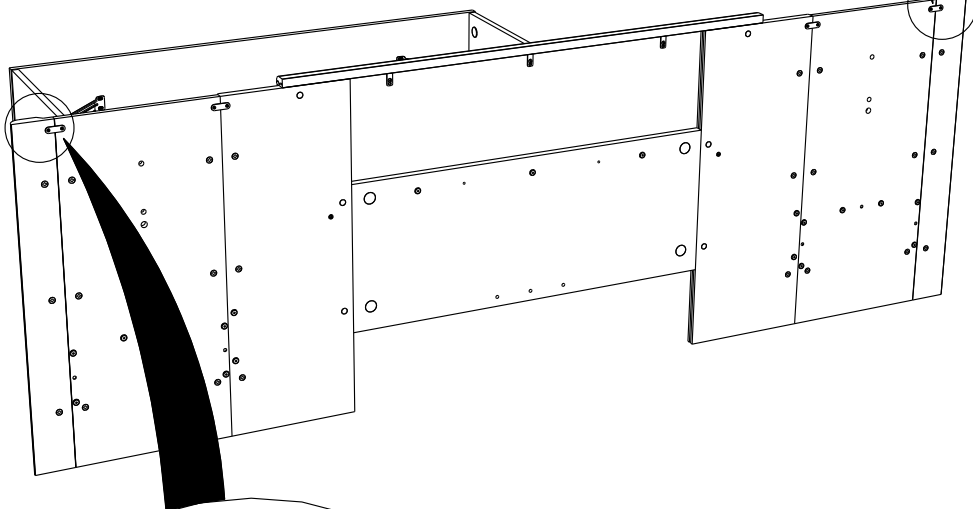
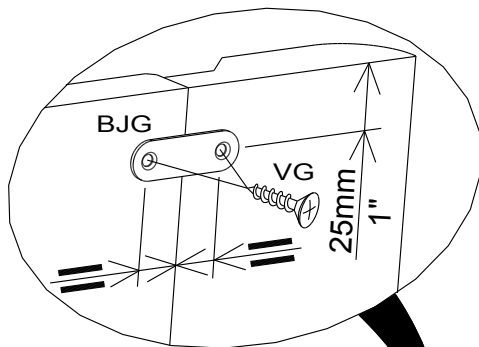

19

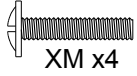

XM x4

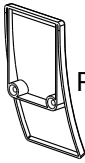

POi x2



POi

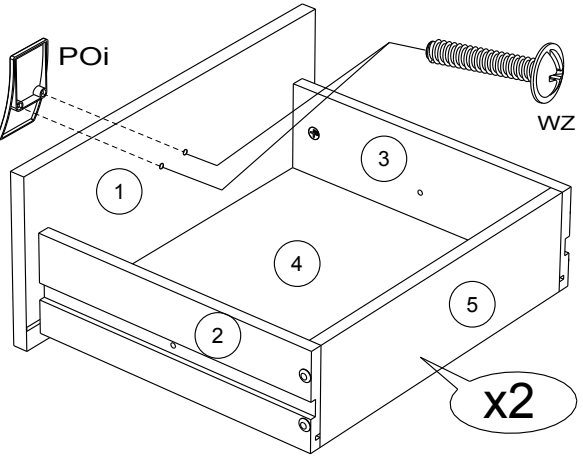

WZ

x2

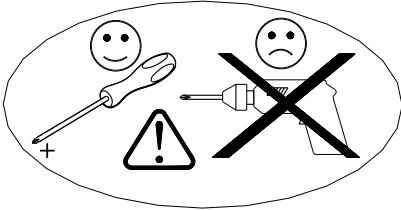

20



VR x4

x2



VR

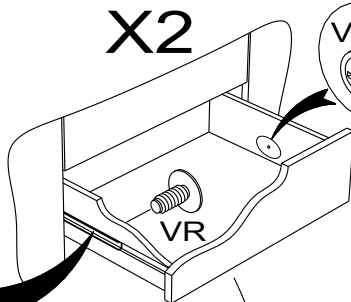
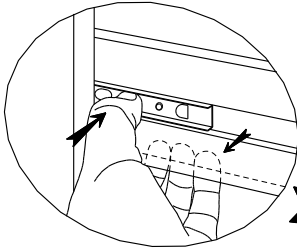

VR

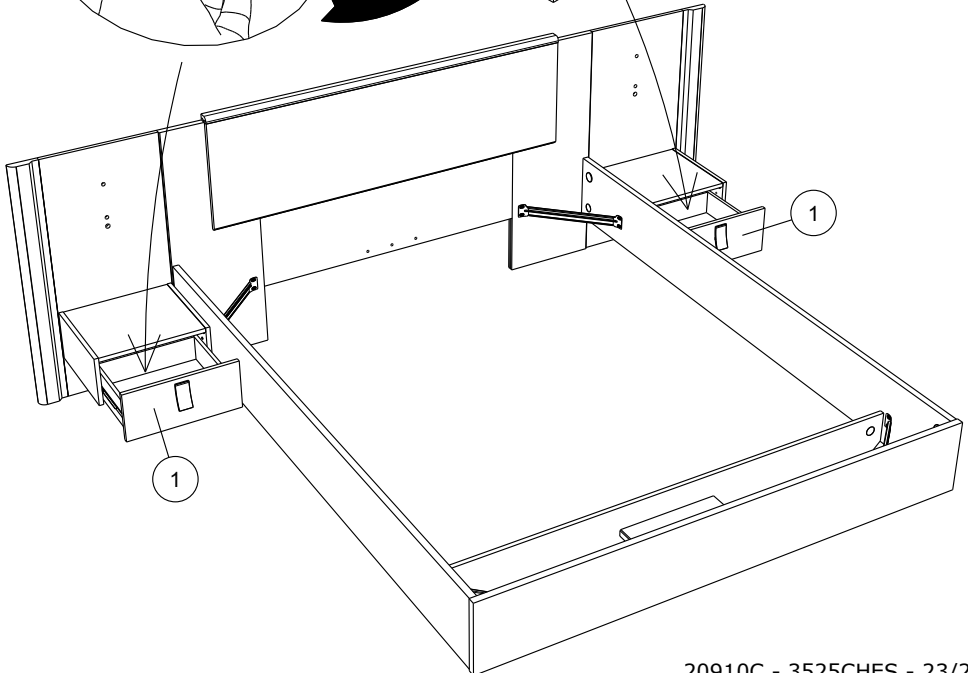

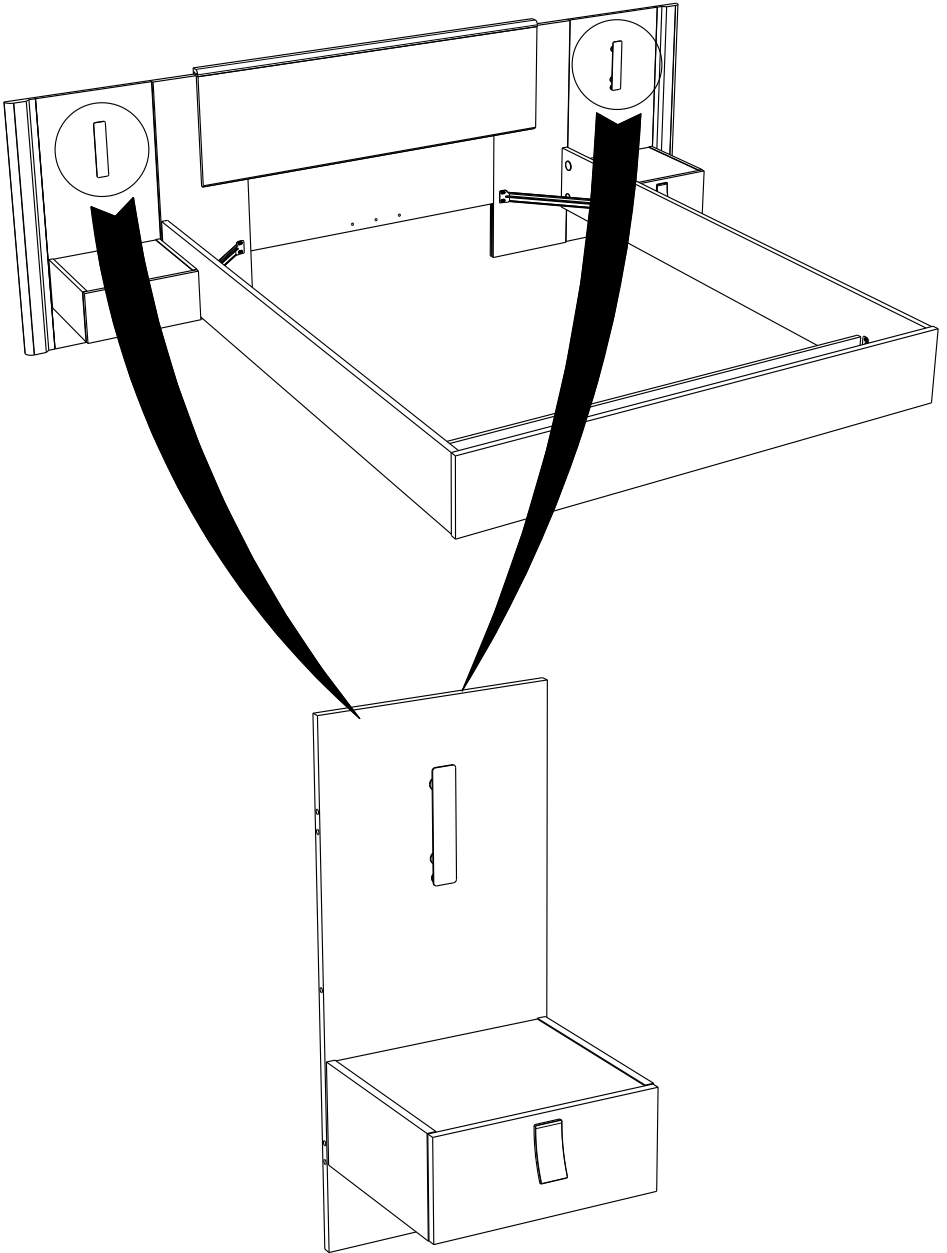

21

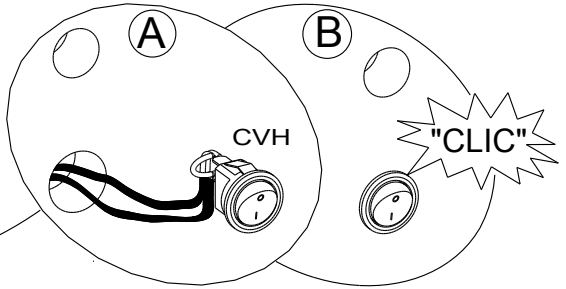
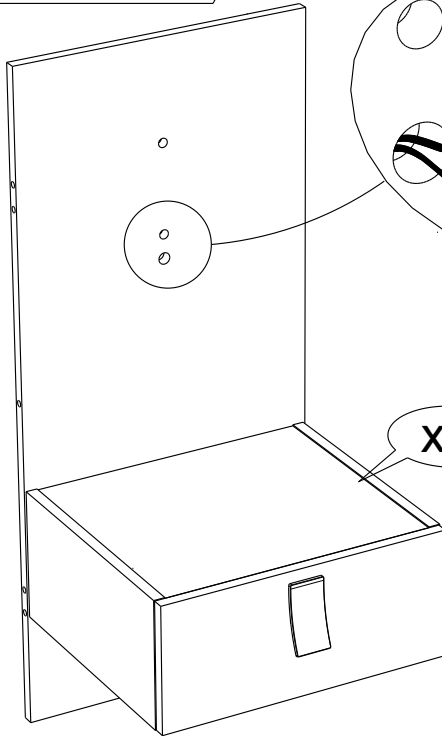
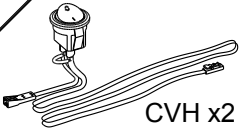

22

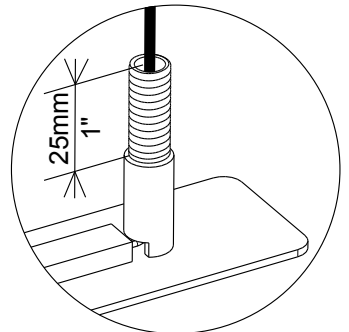
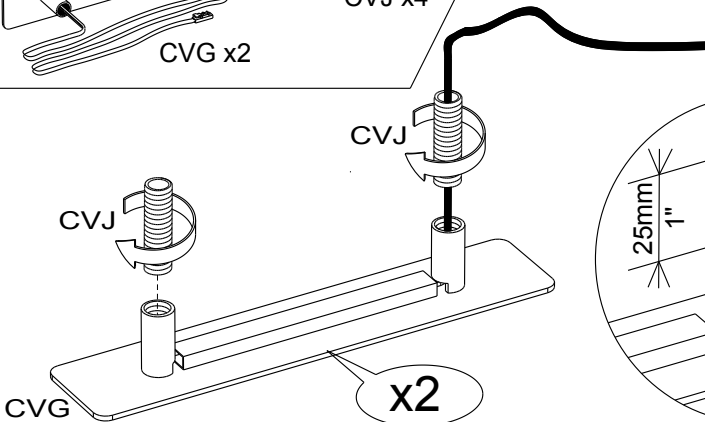
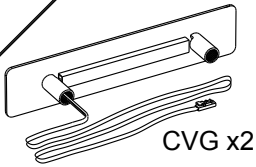

23



CVK x4



CVL x4



CVM x4

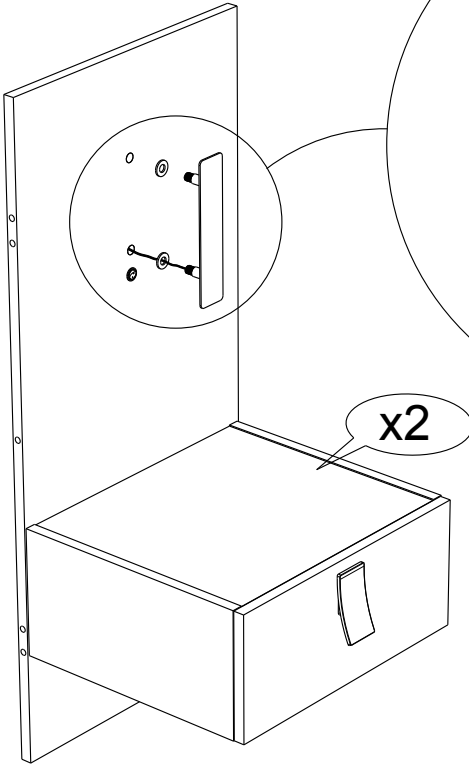

x2

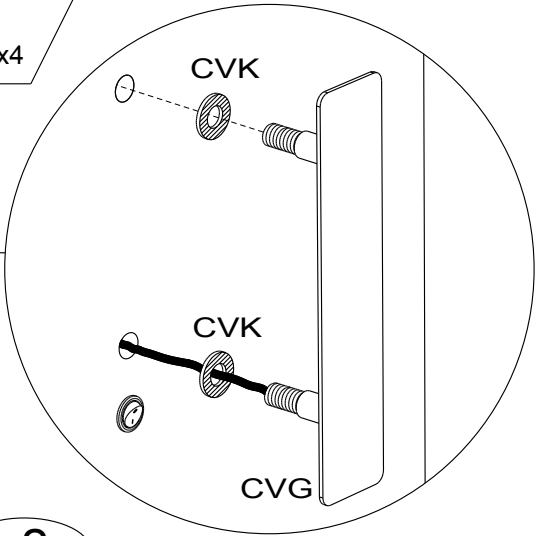

CVK

CVK

CVG

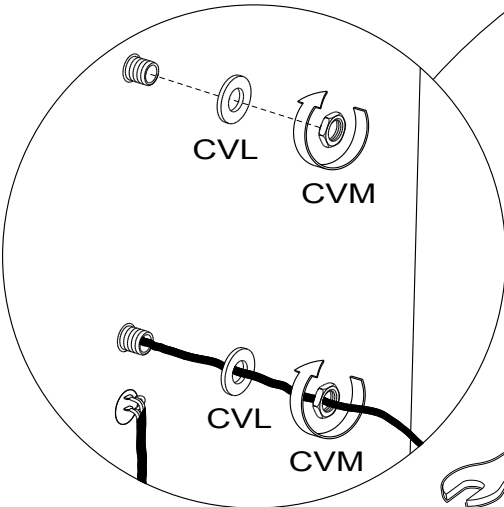

CVL

CVM

CVL

CVM

x2

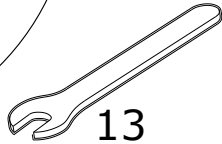
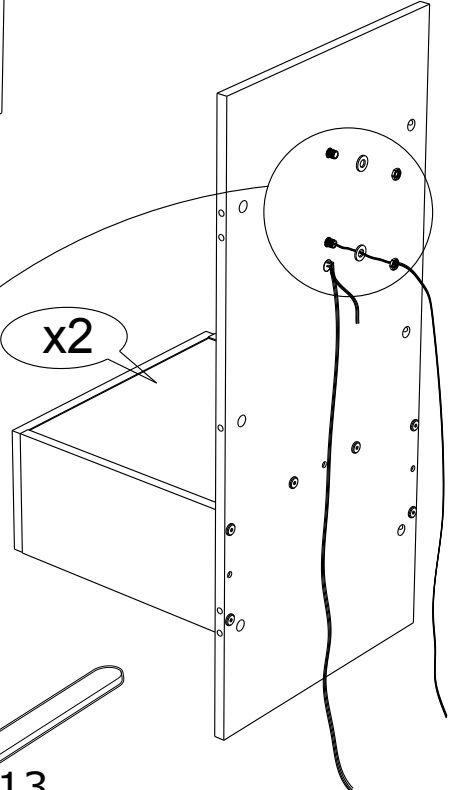

13

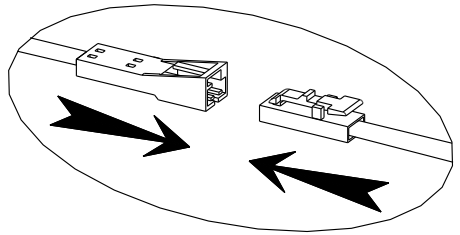
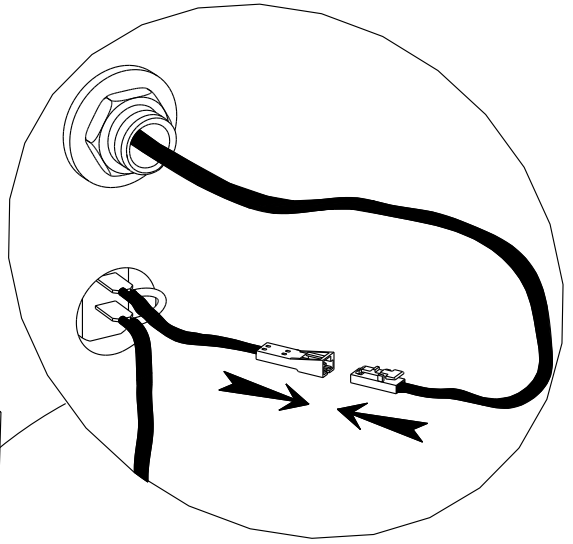
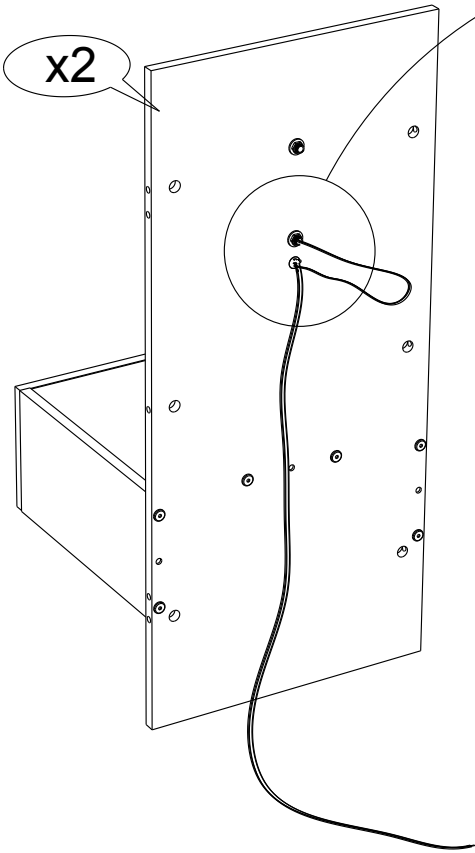

25

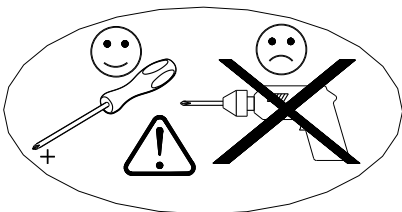
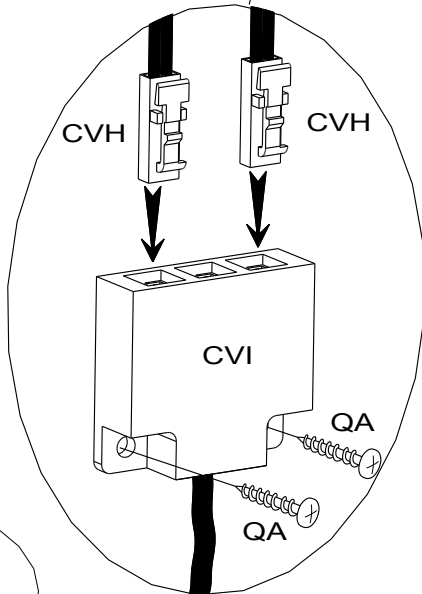
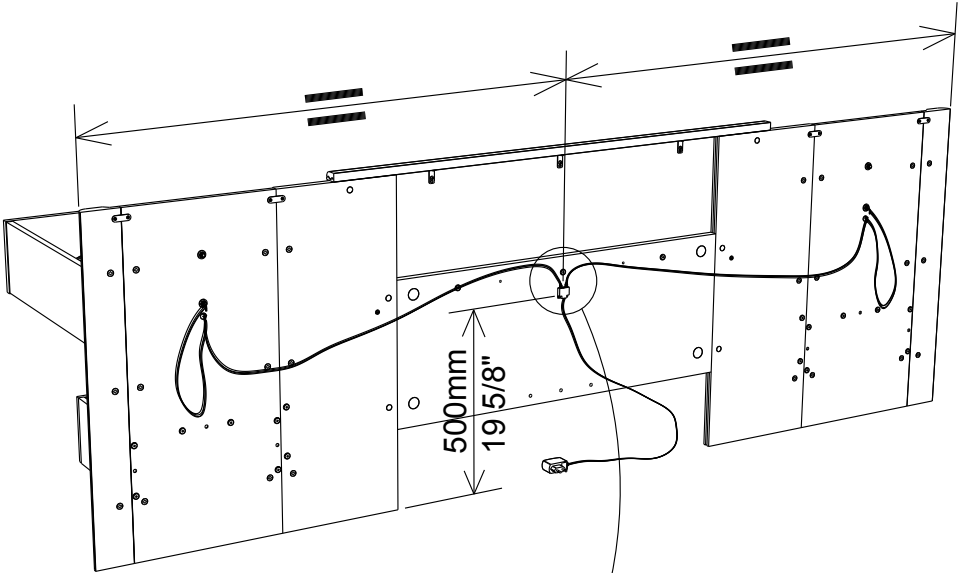
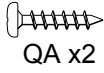
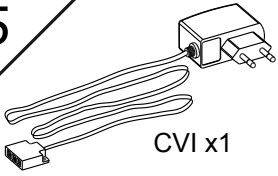

26



BXC x2

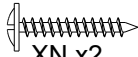

XN x2

