

- FR** NOTICE DE MONTAGE
- EN** ASSEMBLY INSTRUCTIONS
- DE** MONTAGEANLEITUNG
- ES** INSTRUCCIONES DE MONTAJE
- NL** MONTAGEVOORSCHRIFT
- IT** ISTRUZIONI DI MONTAGGIO
- PT** INSTRUÇÕES DE MONTAGEM
- PL** INSTRUKCJA MONTAŻU
- CR** NAPUTCI ZA MONTAŽU
- HU** ÖSSZESZERELÉSI UTASÍTÁSOK

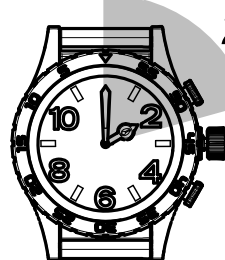

2h30.

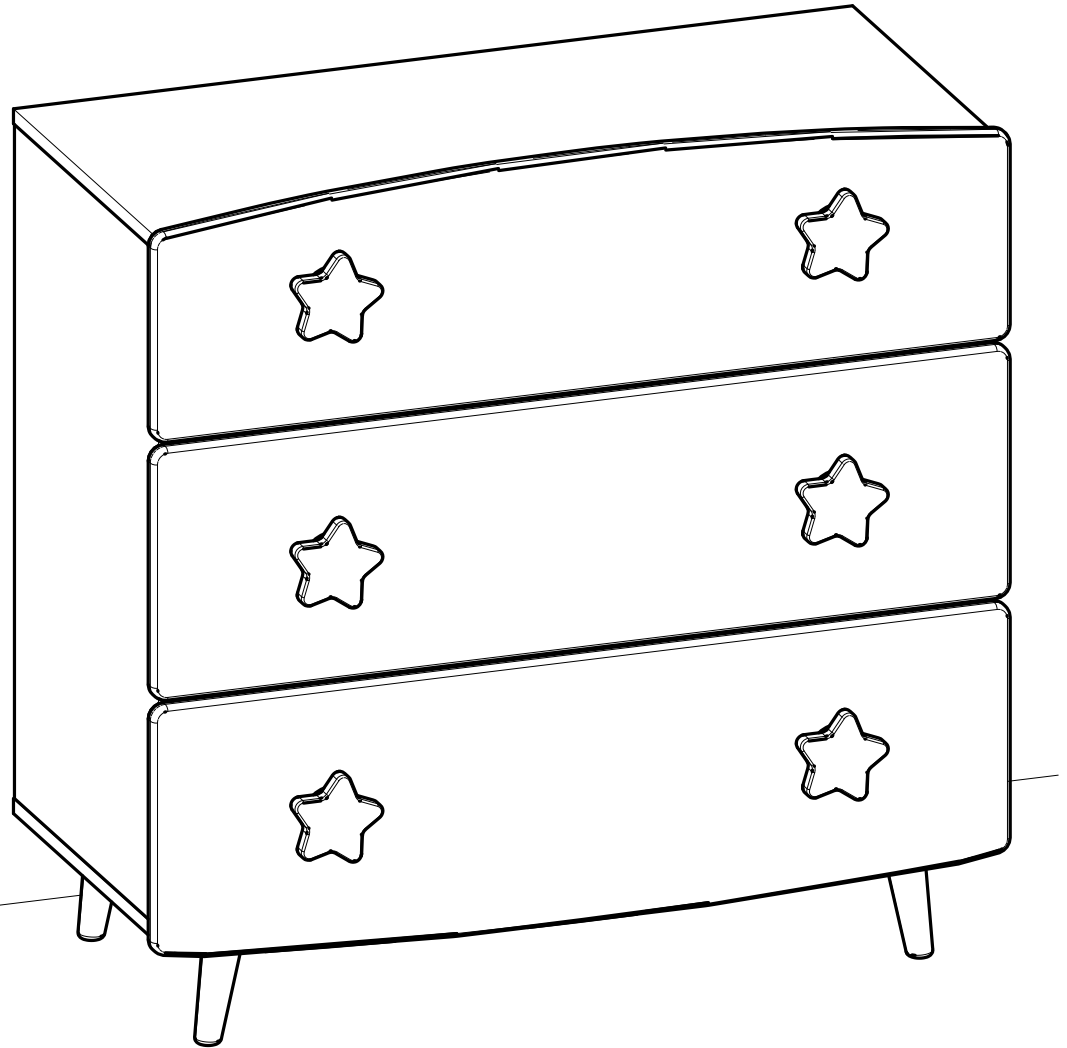

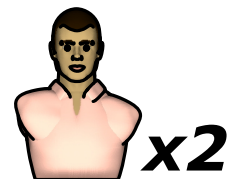
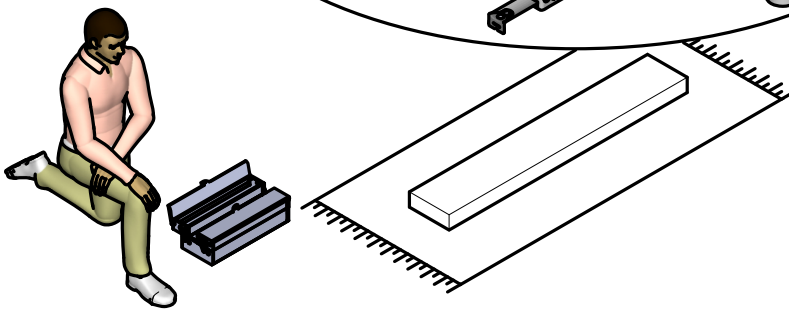
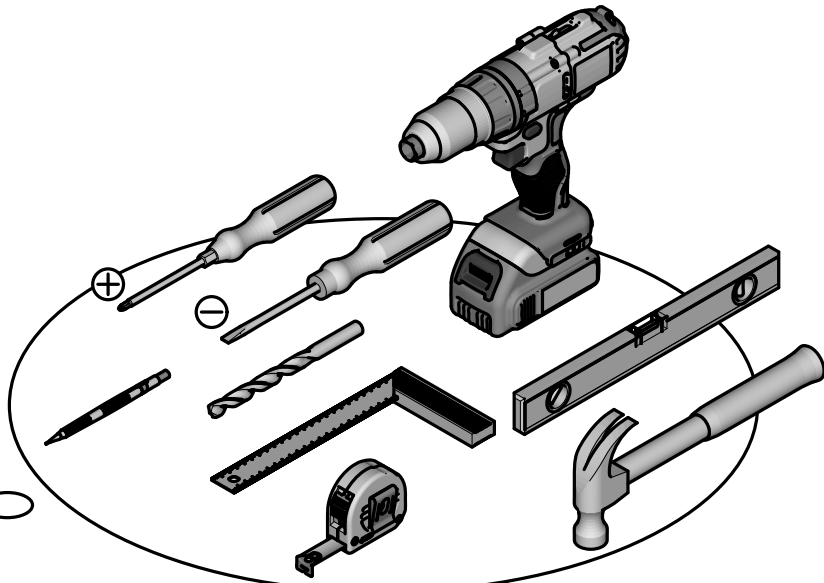
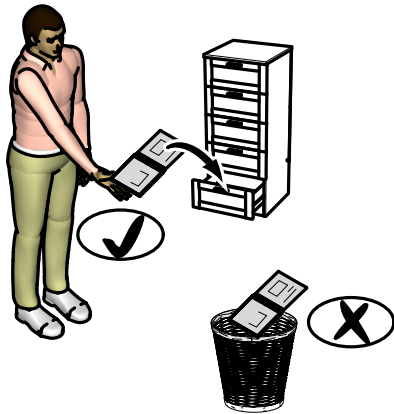
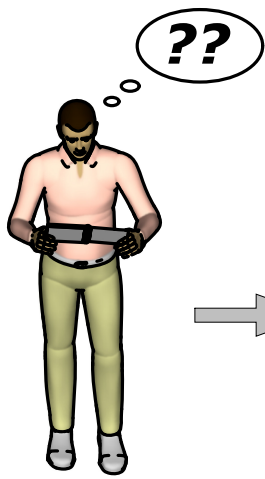

Donnez ou recyclez vos meubles.



Association

ou



Magasin

ou



Déchèterie

<https://www.demeysere.com/fr>

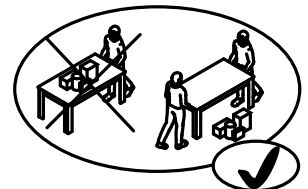
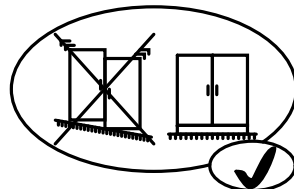
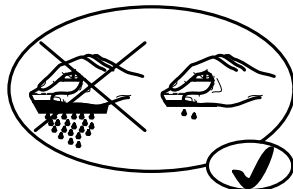
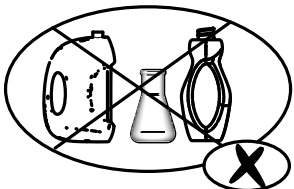

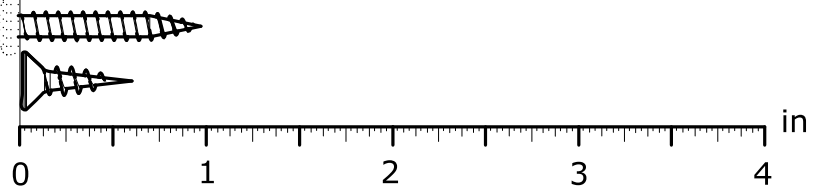
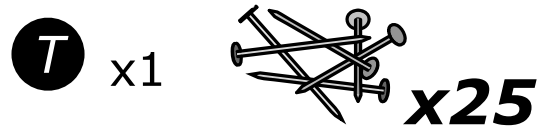
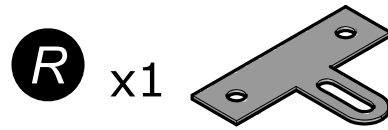
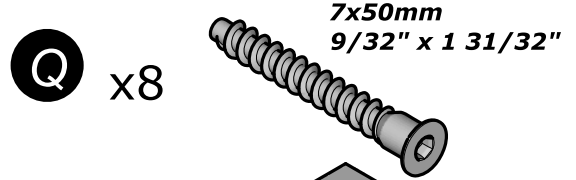
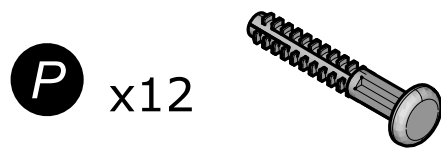
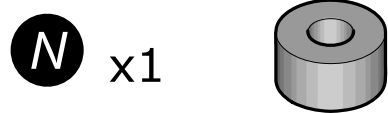
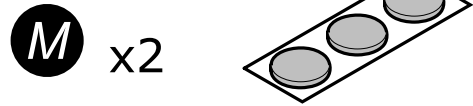
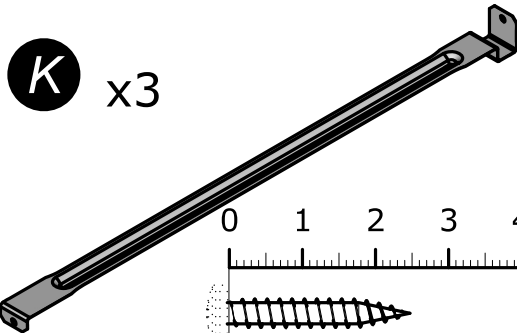
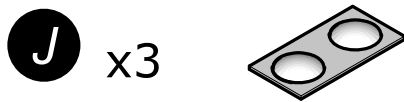
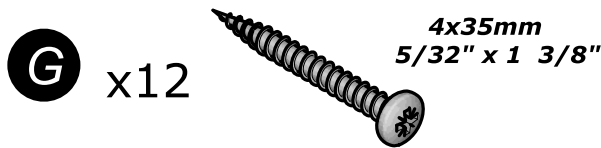
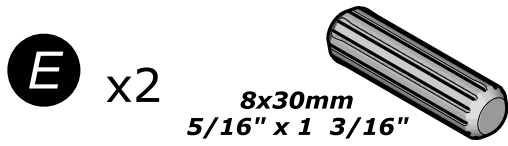
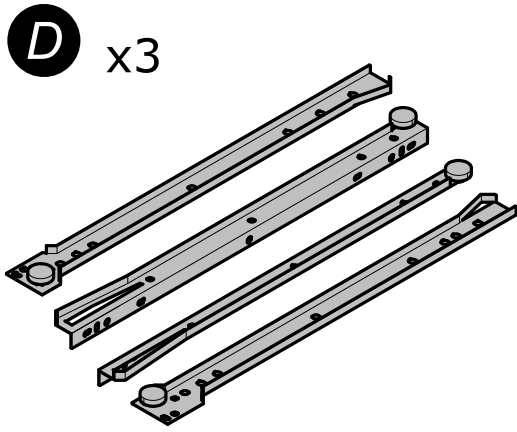

**U** x4

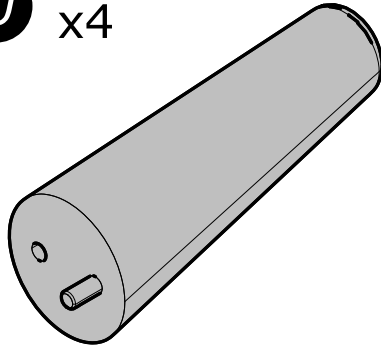

**V** x6

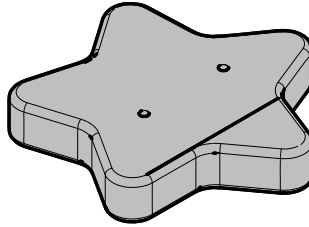

**W** x4

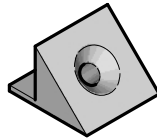

**X** x4

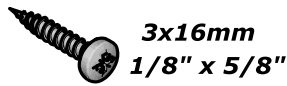

**Y** x6

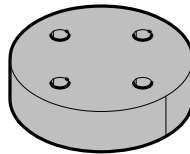

**Z** x12



**AA** x6

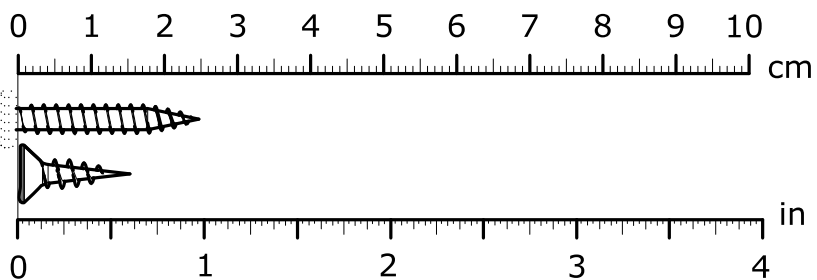



**FR**

**AVERTISSEMENT : MEUBLE A FIXER IMPERATIVEMENT AU MUR AFIN D'EVITER SON BASCULEMENT**

- Pour installer correctement ce produit et éliminer les risques pour votre sécurité, merci de suivre exactement ce manuel d'instruction.
- Fixer le meuble au mur avec les attaches prévues à cet effet
- Les vis et les chevilles ne sont pas fournies. Utiliser des vis et des chevilles adaptées au support.

**EN**

**WARNING: FURNITURE TO BE ATTACHED TO THE WALL TO PREVENT OVERTURNING**

- Installation shall be carried out exactly according to those instructions-otherwise a safety risk can occur if incorrectly installed;
- Attach the furniture to the wall with the fastening provided for this purpose
- Screw and Pegs are not supplied. Use Screws and pegs adapted to the support.

**DE**

**WARNUNG: DAS MÖBEL MUSS AN DER WAND BEFESTIGT WERDEN, UM ZU VERHINDEN DASS ES KIPPT**

- Um das Produkt korrekt zu installieren und um Risiken für Ihre Sicherheit zu verhindern, die Gebrauchsanleitung genauestens befolgen.
- Das Möbel mit den vorgesehenen Befestigungen an einer Wand befestigen.
- Schrauben und Dübel sind nicht im Lieferumfang enthalten. Passende Schrauben und Dübel verwenden.

**ES**

**ADVERTENCIA: ESTE MUEBLE DEBE ESTAR SIEMPRE FIJO EN LA PARED PARA EVITAR QUE VUELQUE**

- Para instalar correctamente este producto y eliminar los riesgos para la seguridad, seguir exactamente las instrucciones del manual.
- Fijar el mueble a la pared con las sujeciones previstas a este efecto.
- Los tornillos y los tacos no están incluidos. Utilizar tornillos y tacos adaptados al soporte.

**NL**

**WAARSCHUWING: MEUBEL MOET VERPLICHT AAN DE MUUR BEVESTIGD WORDEN ZODAT HET NIET KAN OMVALLEN**

- Om dit product correct te installeren en alle risico's voor uw veiligheid te elimineren, gelieve de instructies in deze handleiding nauwgezet op te volgen.
- Zet het meubel vast aan de muur met de hiertoe voorziene bevestigingen.
- De schroeven en pluggen zijn niet meegeleverd. Gebruik schroeven en pluggen die geschikt zijn voor het materiaal van de muur.

**IT**

**AVVERTENZA: MOBILE DA FISSARE IMPERATIVAMENTE AL MURO PER EVITARE CHE SI RIBALTI**

- Per installare correttamente questo prodotto ed eliminare i rischi per la vostra sicurezza, si prega di seguire esattamente il manuale d'istruzioni.
- Fissare il mobile al muro con gli appositi ganci.
- Le viti e i tasselli non sono forniti. Utilizzare viti e tasselli adatti al supporto.

**PT**

**ADVERTÊNCIA: MÓVEL A FIXAR OBRIGATORIAMENTE À PAREDE PARA EVITAR A SUA QUEDA**

- Para instalar corretamente este produto e eliminar os riscos para a sua segurança, é favor seguir exatamente este manual de instruções.
- Fixe o móvel à parede com as fixações previstas para o efeito
- Os parafusos e as cavilhas não são fornecidos. Utilize parafusos e cavilhas adaptados ao suporte.

**PL**

**OSTRZEŻENIE: MEBEL NALEŻY PRZYMOCOWAĆ DO ŚCIANY, ABY UNIKNĄĆ JEGO PRZEWRÓCENIA**

- Aby prawidłowo zainstalować ten produkt i wyeliminować zagrożenie dla bezpieczeństwa użytkownika, należy postępować zgodnie z niniejszą instrukcją.
- Przymocować mebel do ściany za pomocą mocowań przewidzianych w tym celu.
- Śruby i nakrętki nie znajdują się w zestawie. Użyć śrub i nakrętek dostosowanych do wspornika.

**CR**

**UPOZORENJE : UČVRSTITE ORMARIĆ NA ZID KAKO BISTE SPRIJEČILI NJEGOVO LJULJANJE**

- Kako biste pravilno postavili ovaj proizvod i uklonili sigurnosne rizike kojima se izlažete, pridržavajte se strogo ovog priručnika s uputama.
- Postavite ormarić na zid pripadajućim sponama.Vijci i svornjci ne isporučuju se. Upotrijebite nosne vijke i svornjke.

**HU**

**FIGYELEM: A BÚTORT FELTÉTENÜL RÖGZÍTENI KELL A FALHOZ, HOGY ELKERÜLJE A FELBILLENÉSÉT**

- A termék megfelelő elhelyezéséhez és a biztonságot érintő kockázatok kiküszöböléséhez pontosan kövesse ezt a használati útmutatót.
- Rögzítse a bútort a falhoz az erre a célra szolgáló rögzítőelemekkel.
- A csavarok és a tiplik nincsenek mellékelve. Használjon a tartóhoz illő csavarokat és tipliket.

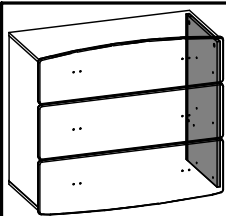

1

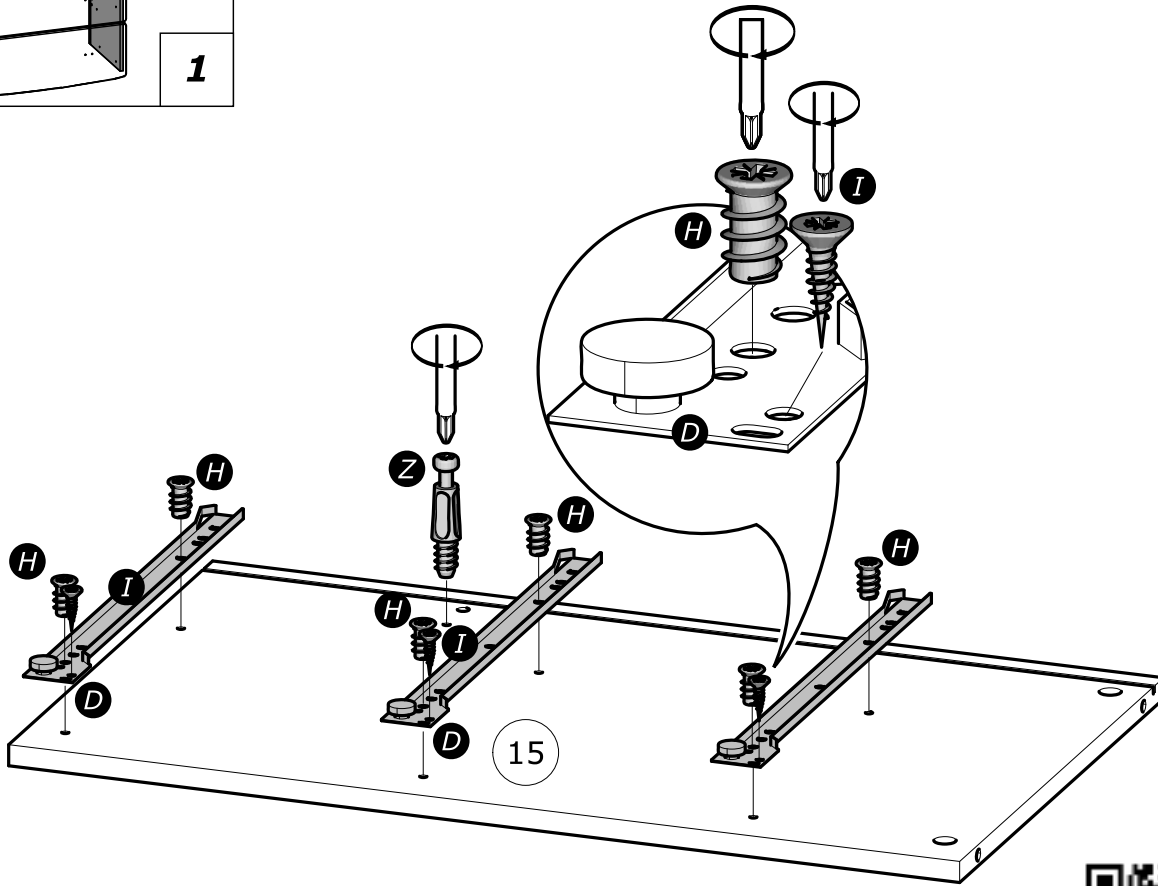
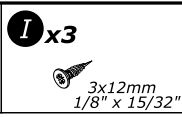
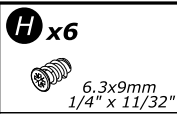
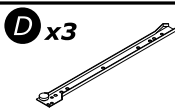
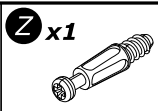

[www.Demeyere.fr](http://www.Demeyere.fr)

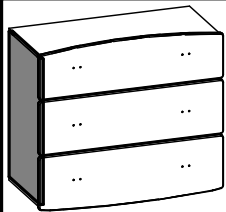

2

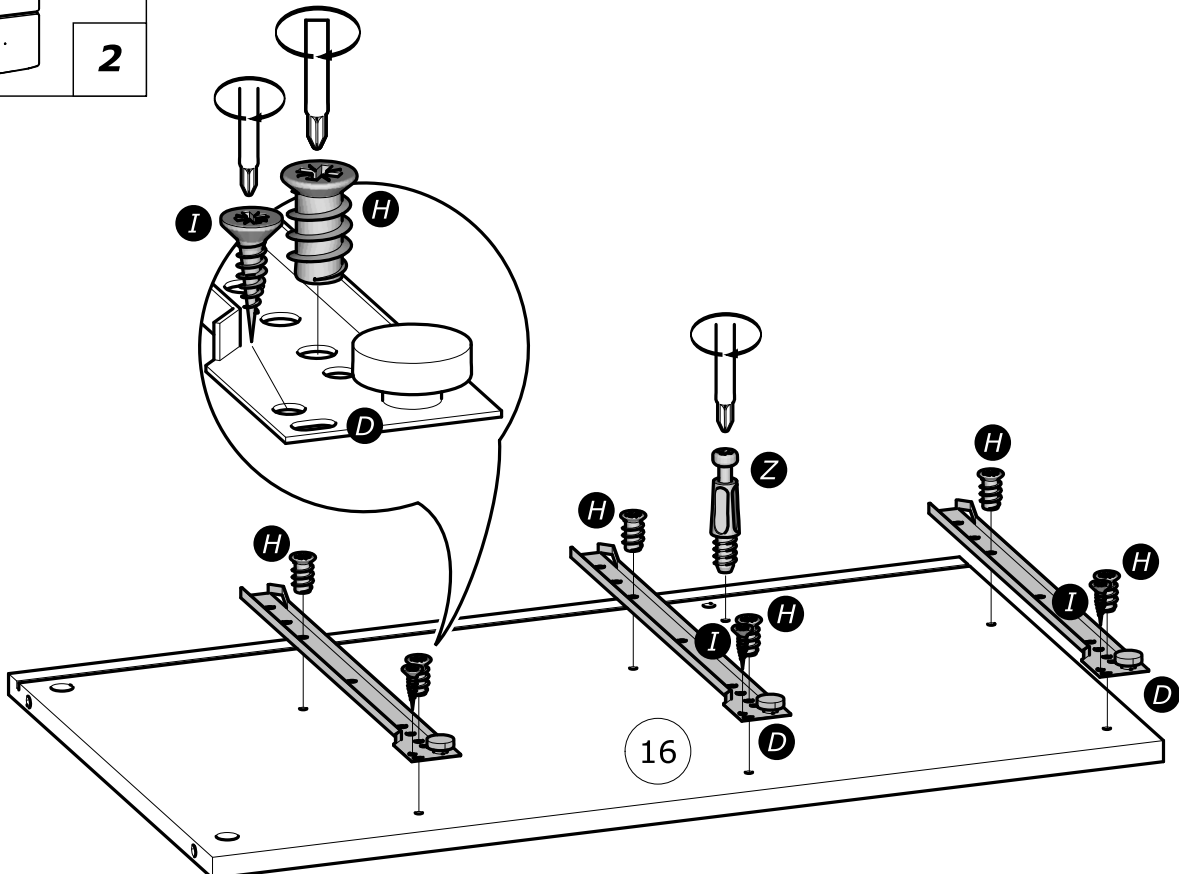
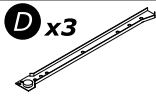
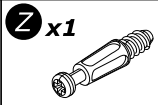

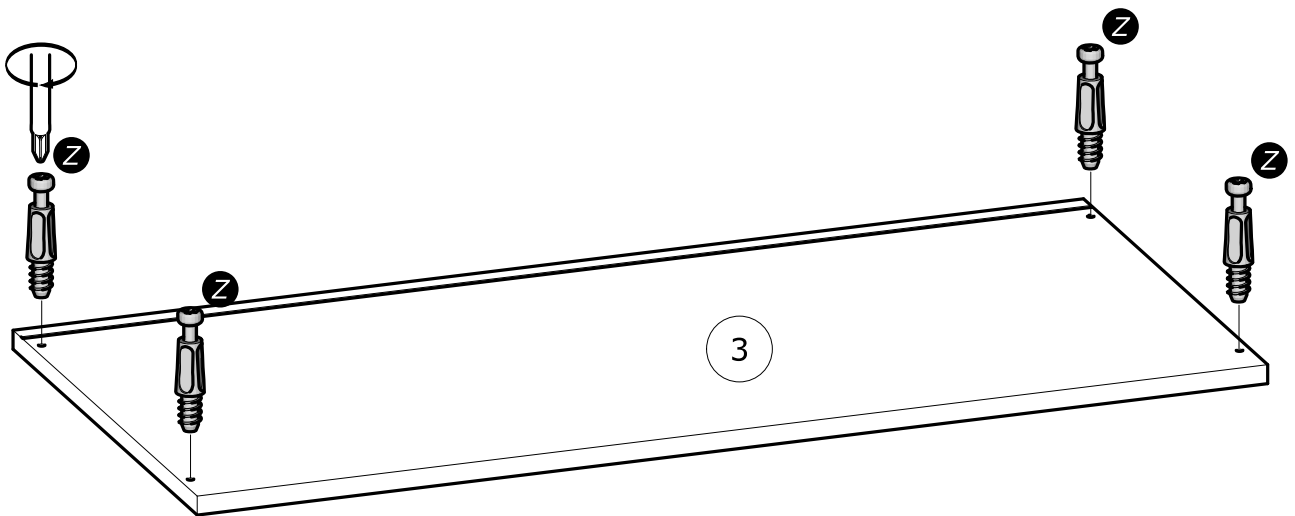
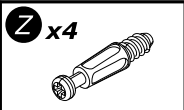
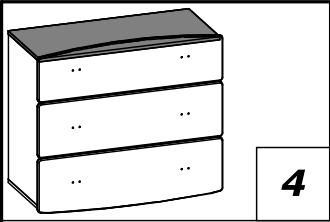
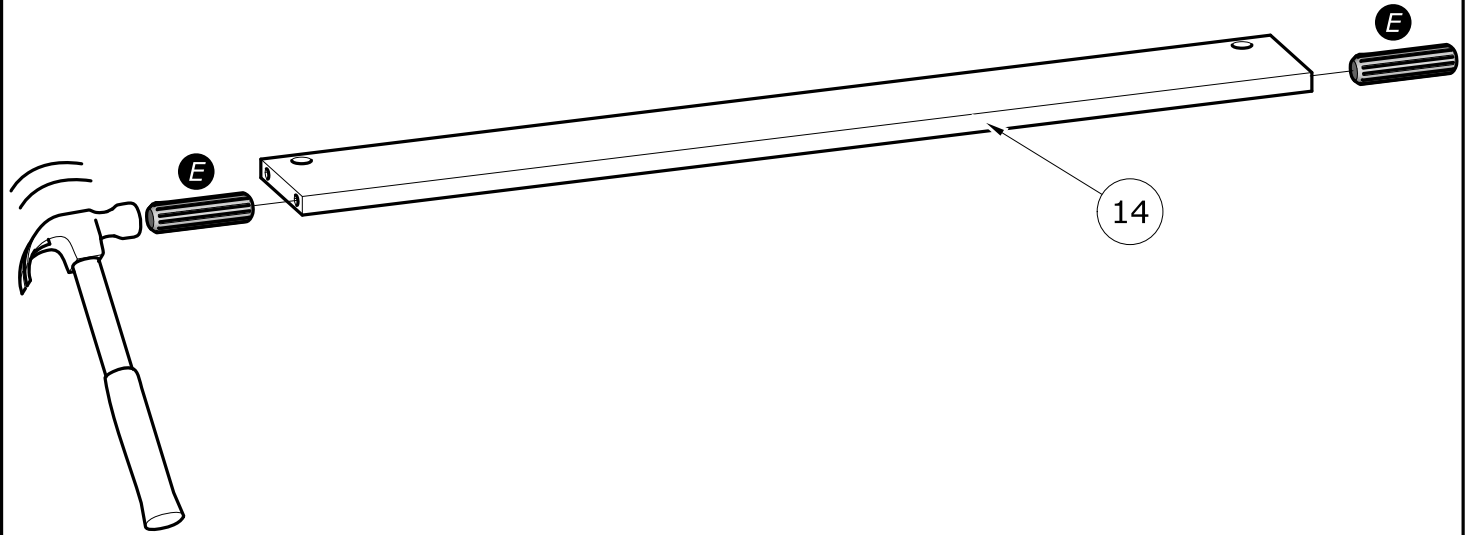
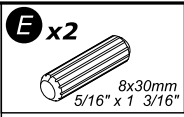
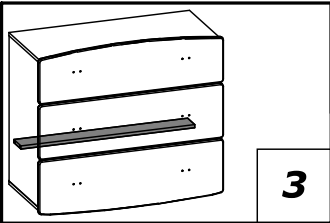

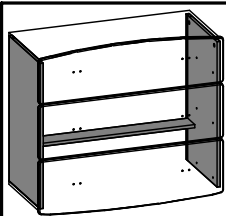

5

AA x2  
Ø15mm  
Ø19/32"

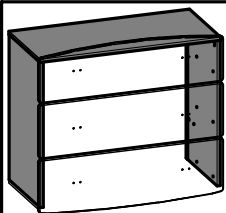
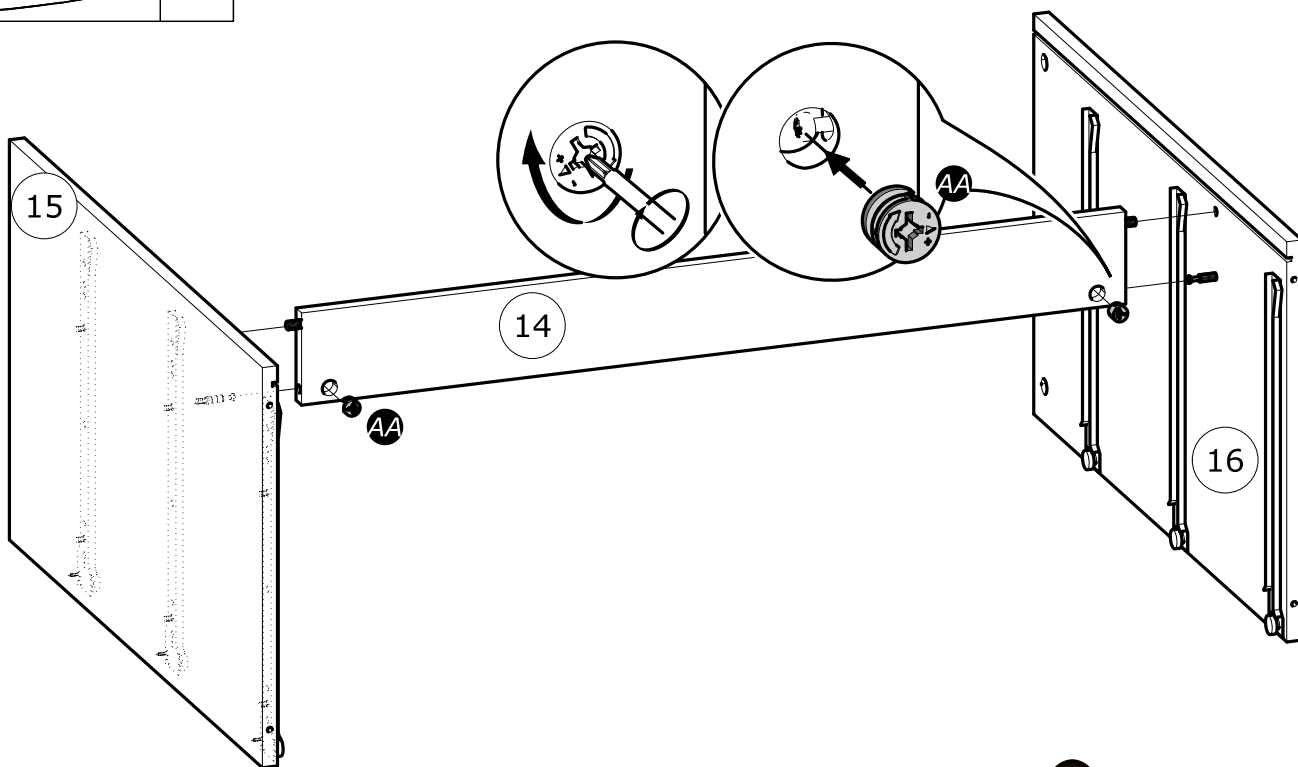

6

AA x4  
Ø15mm  
Ø19/32"

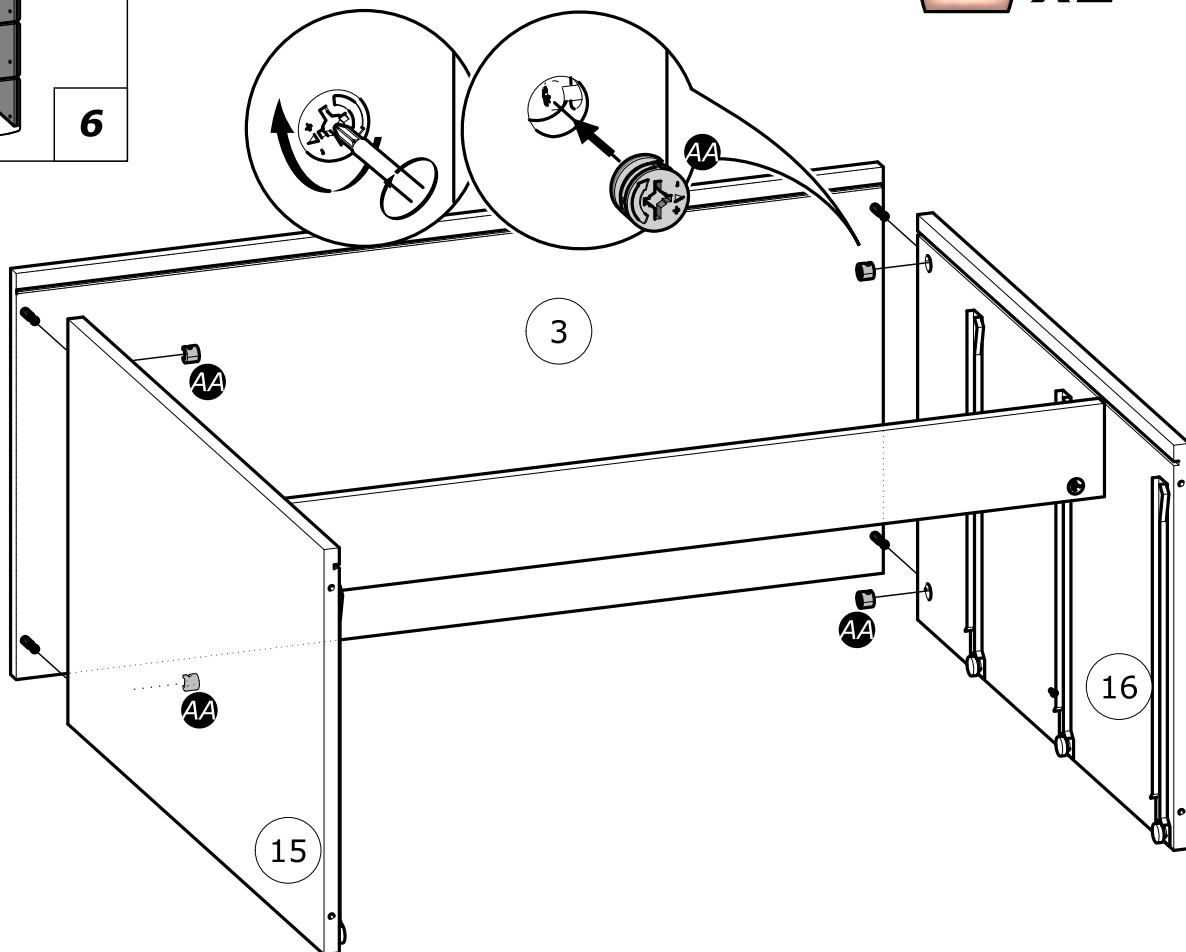

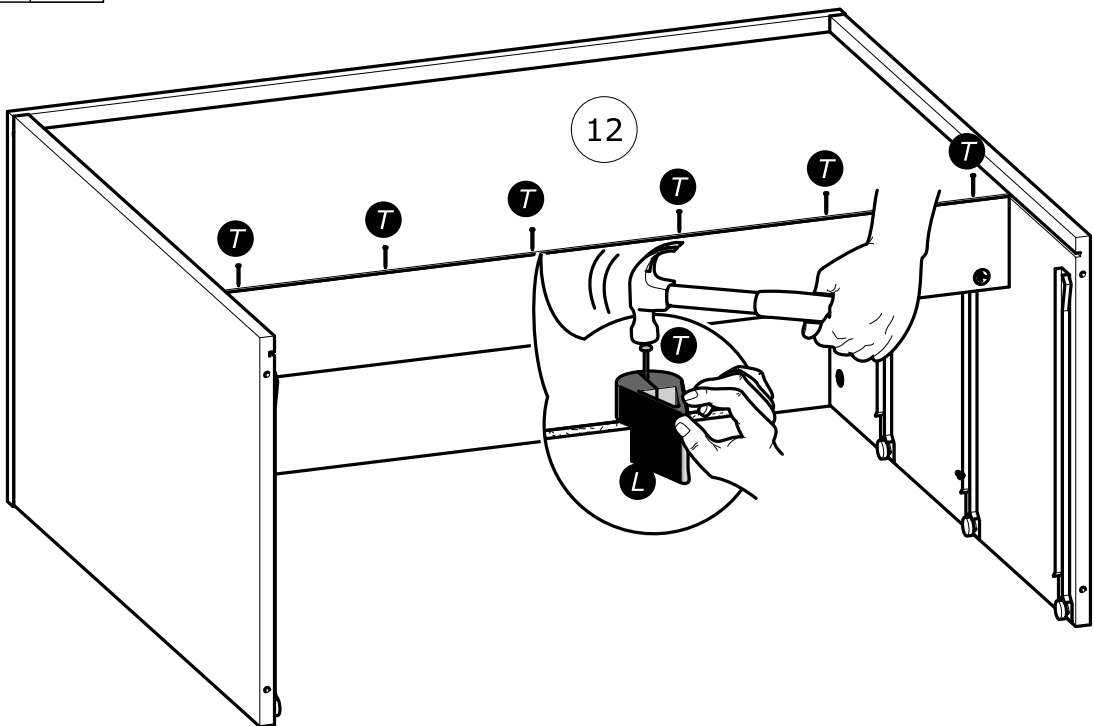
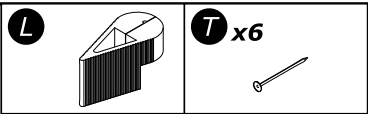
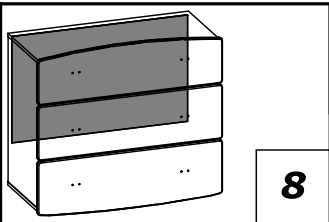
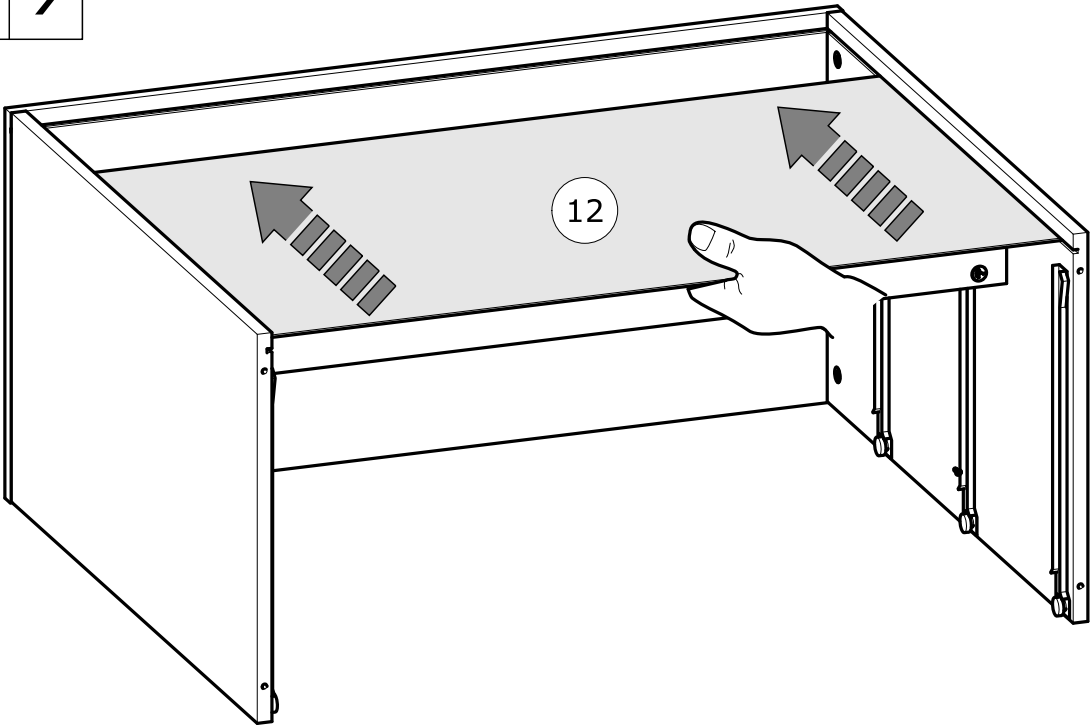
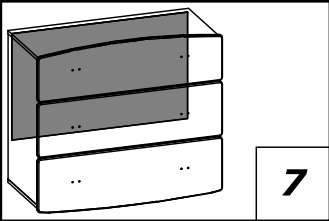

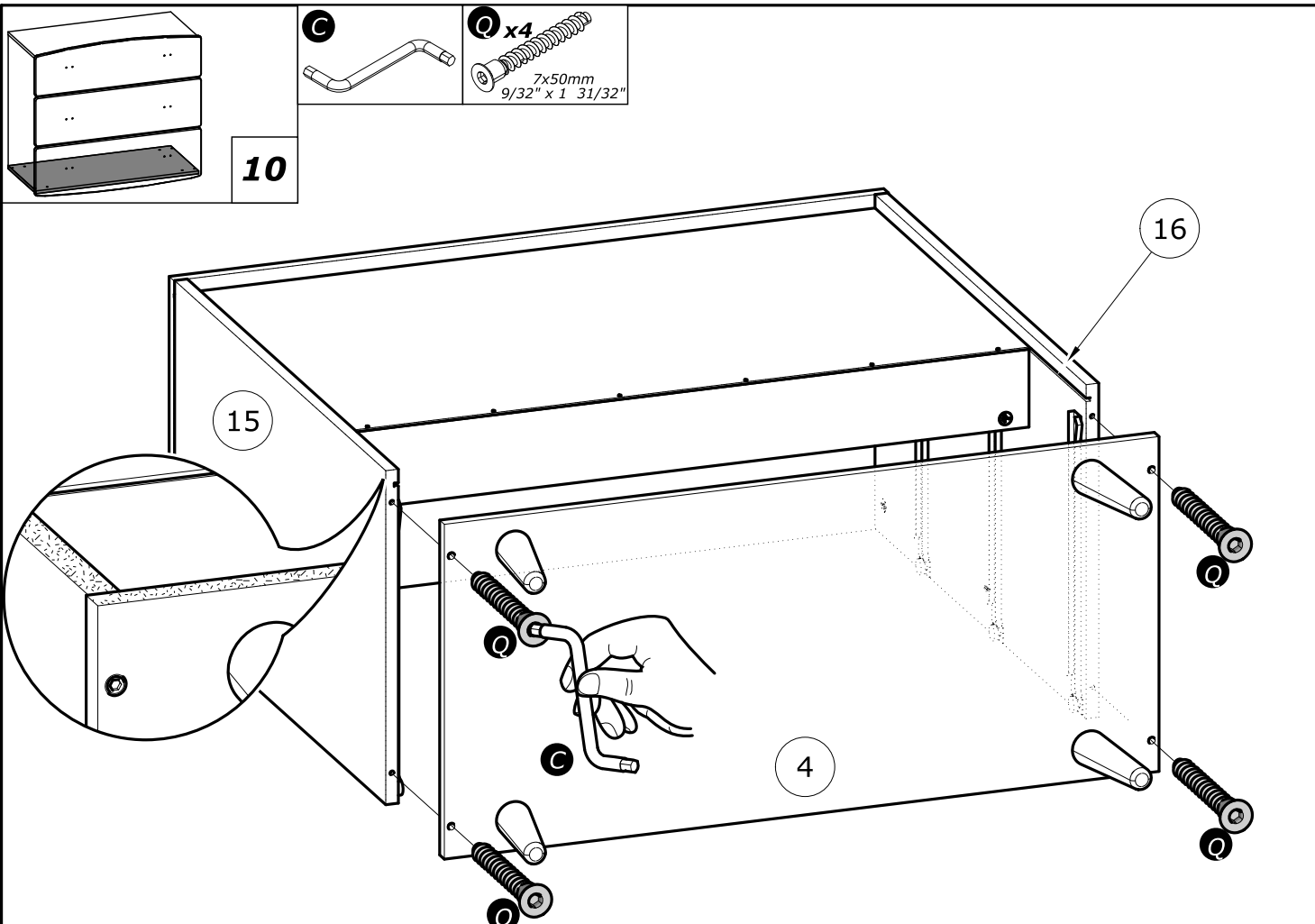
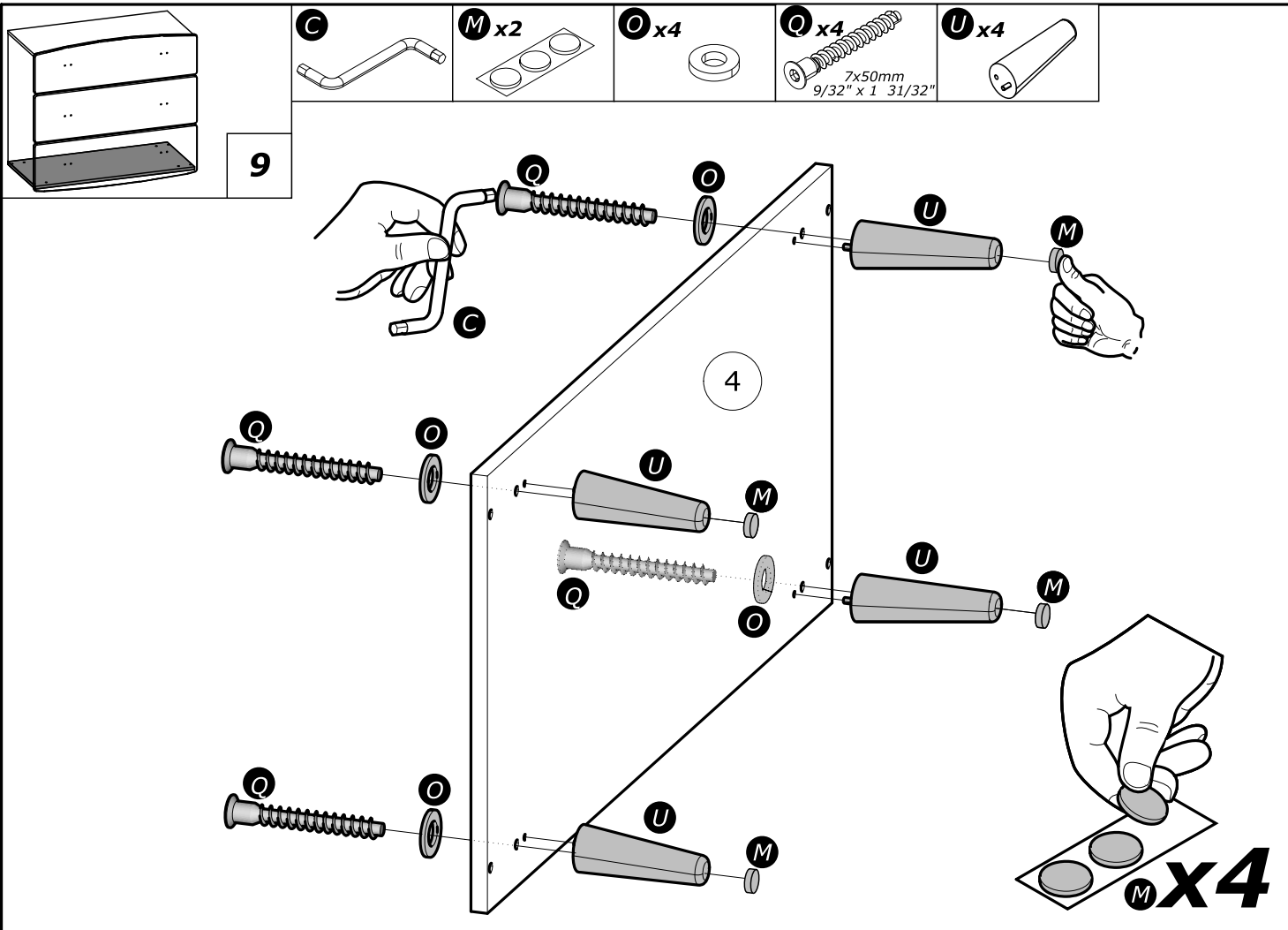

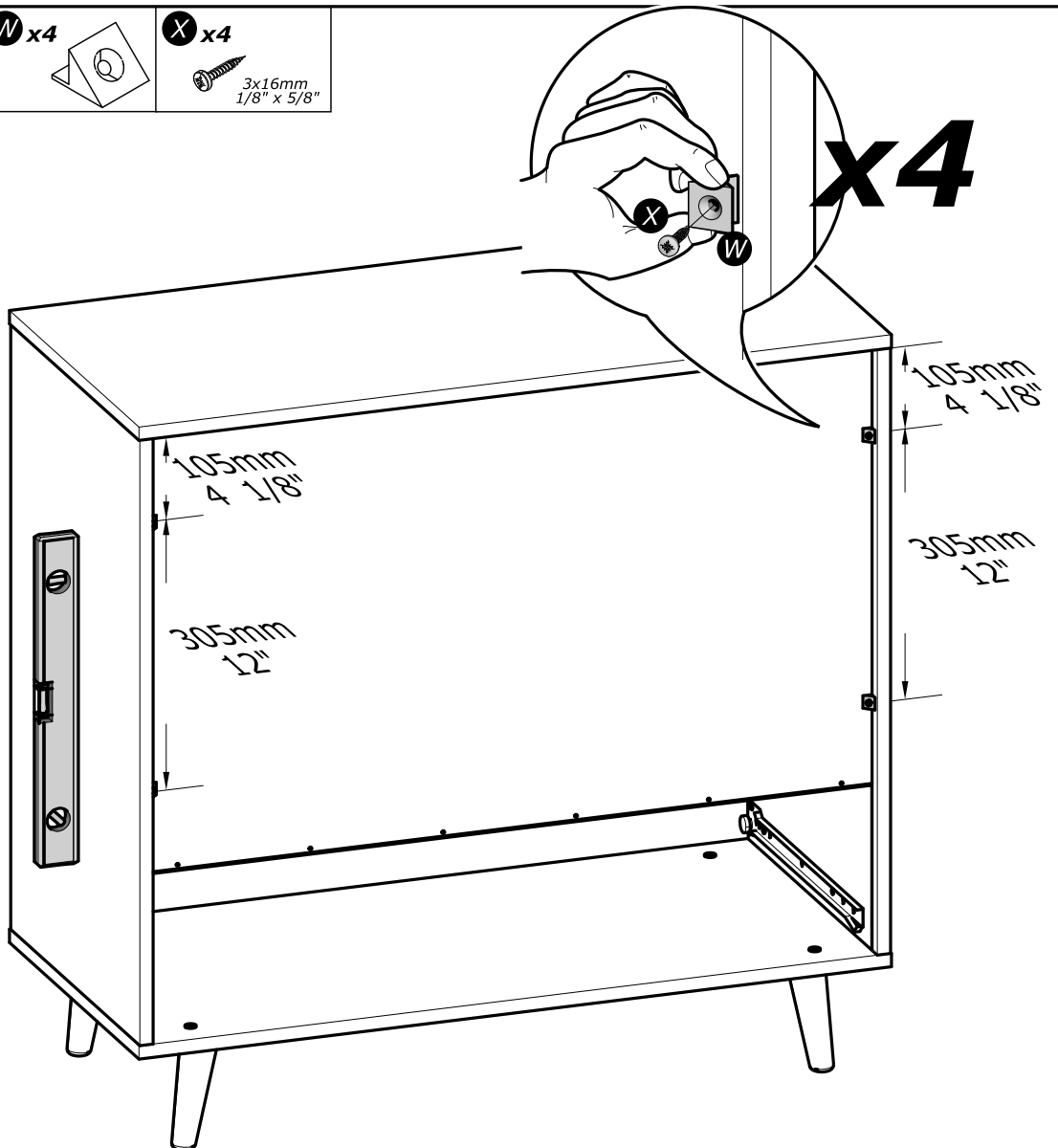
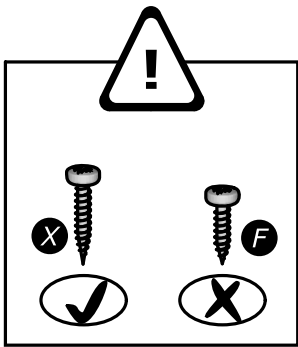
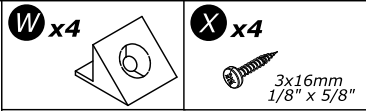
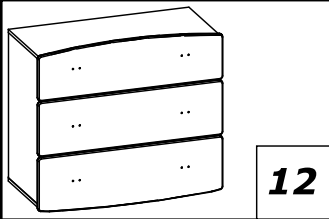
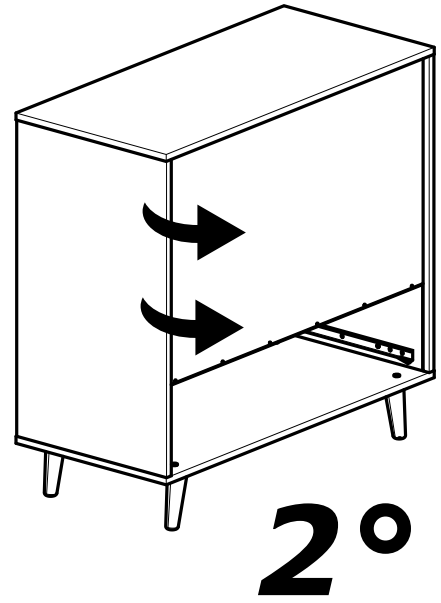
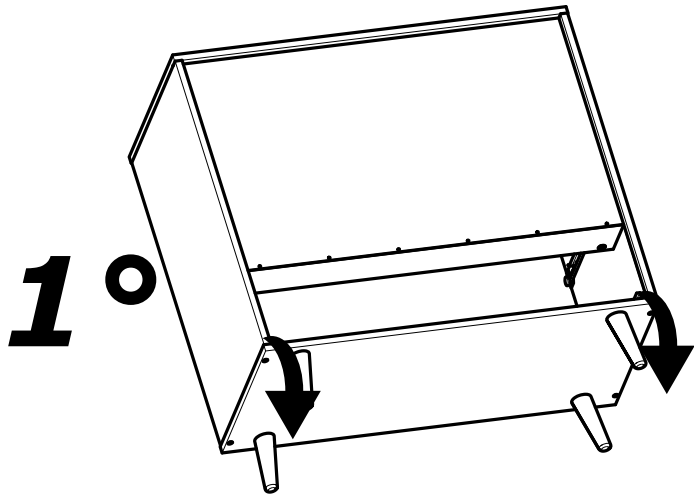
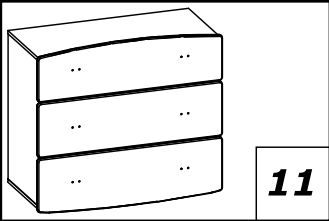

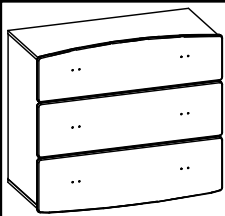

13

**F** x2  
3x12mm  
1/8" x 15/32"

**N** x1

**R** x1

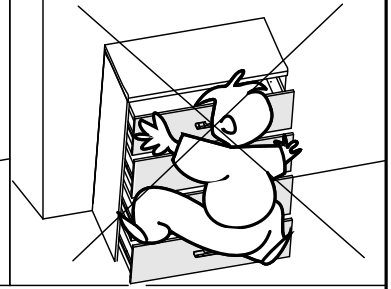
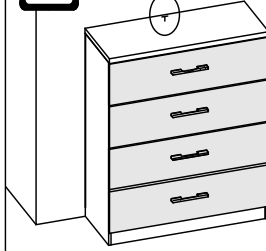

1°

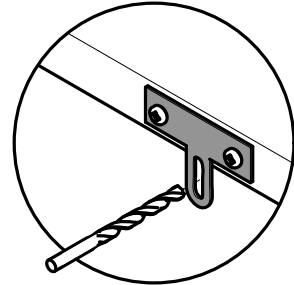
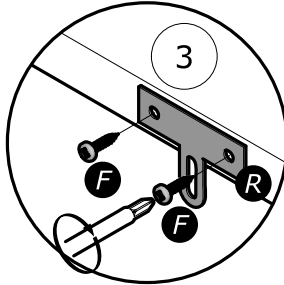
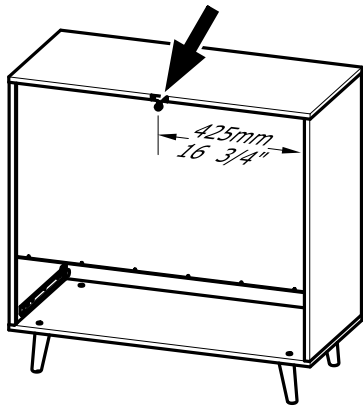

2°

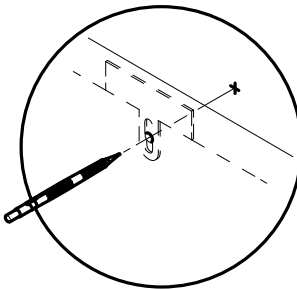
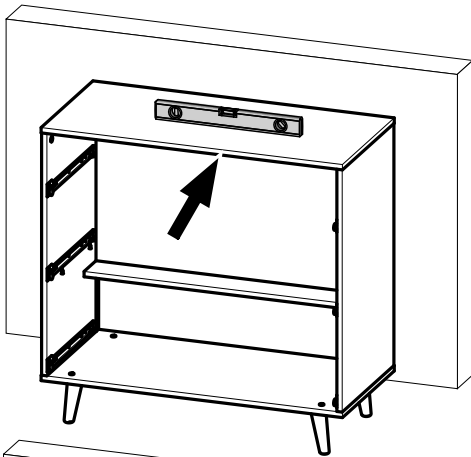

3°

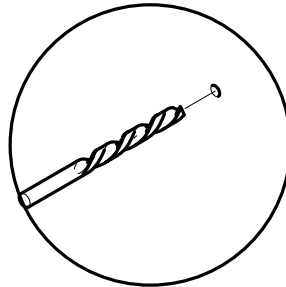
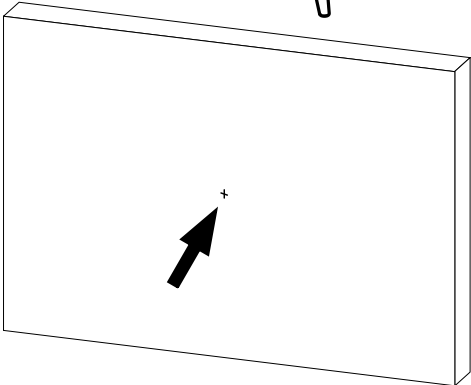

4°

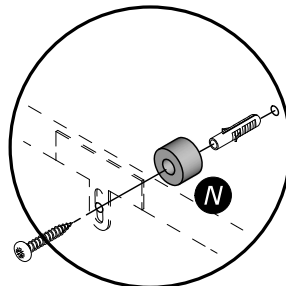
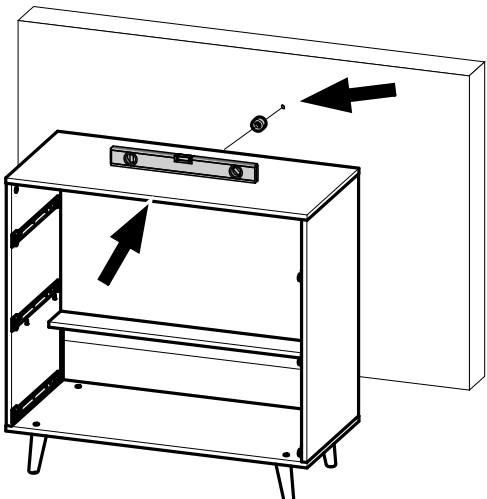

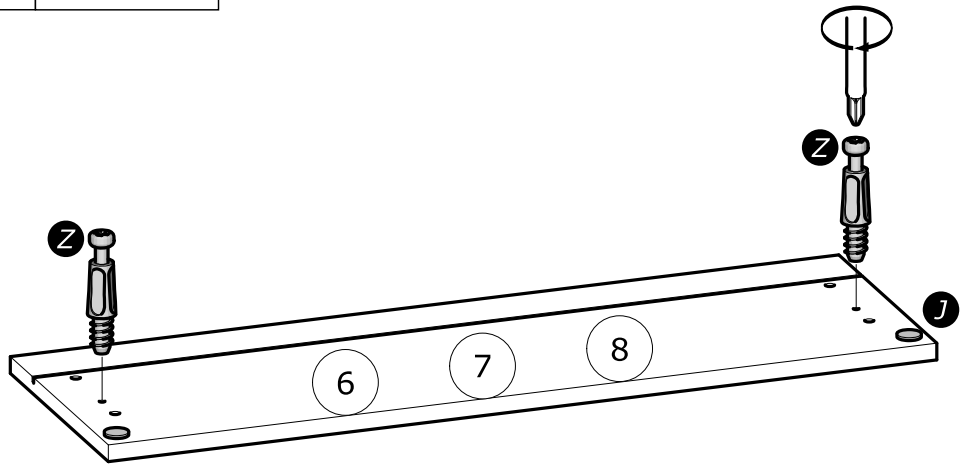
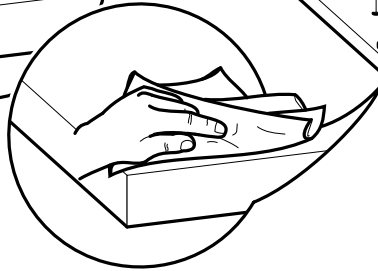
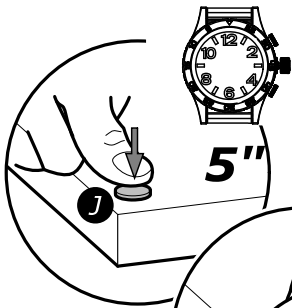
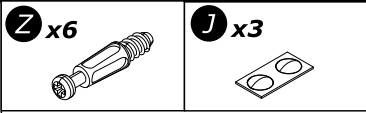
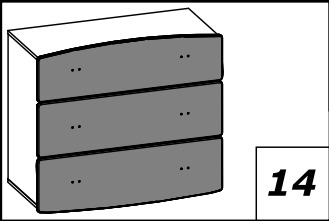

x3

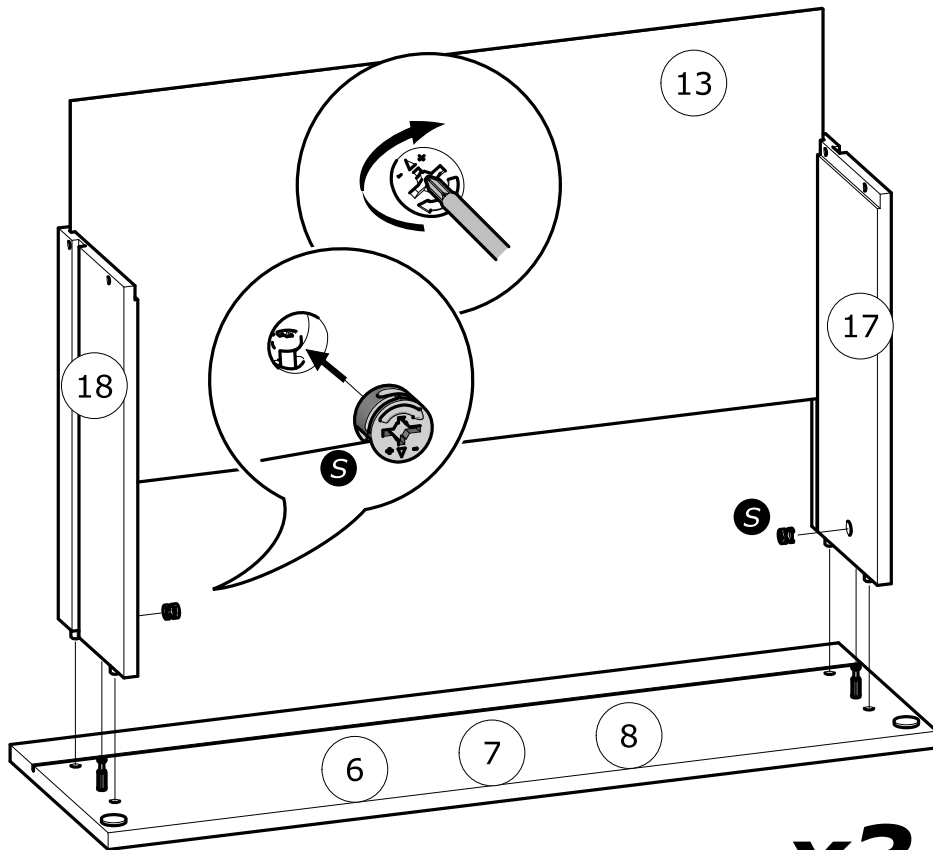
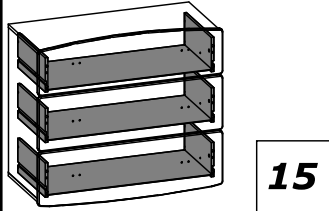

x3

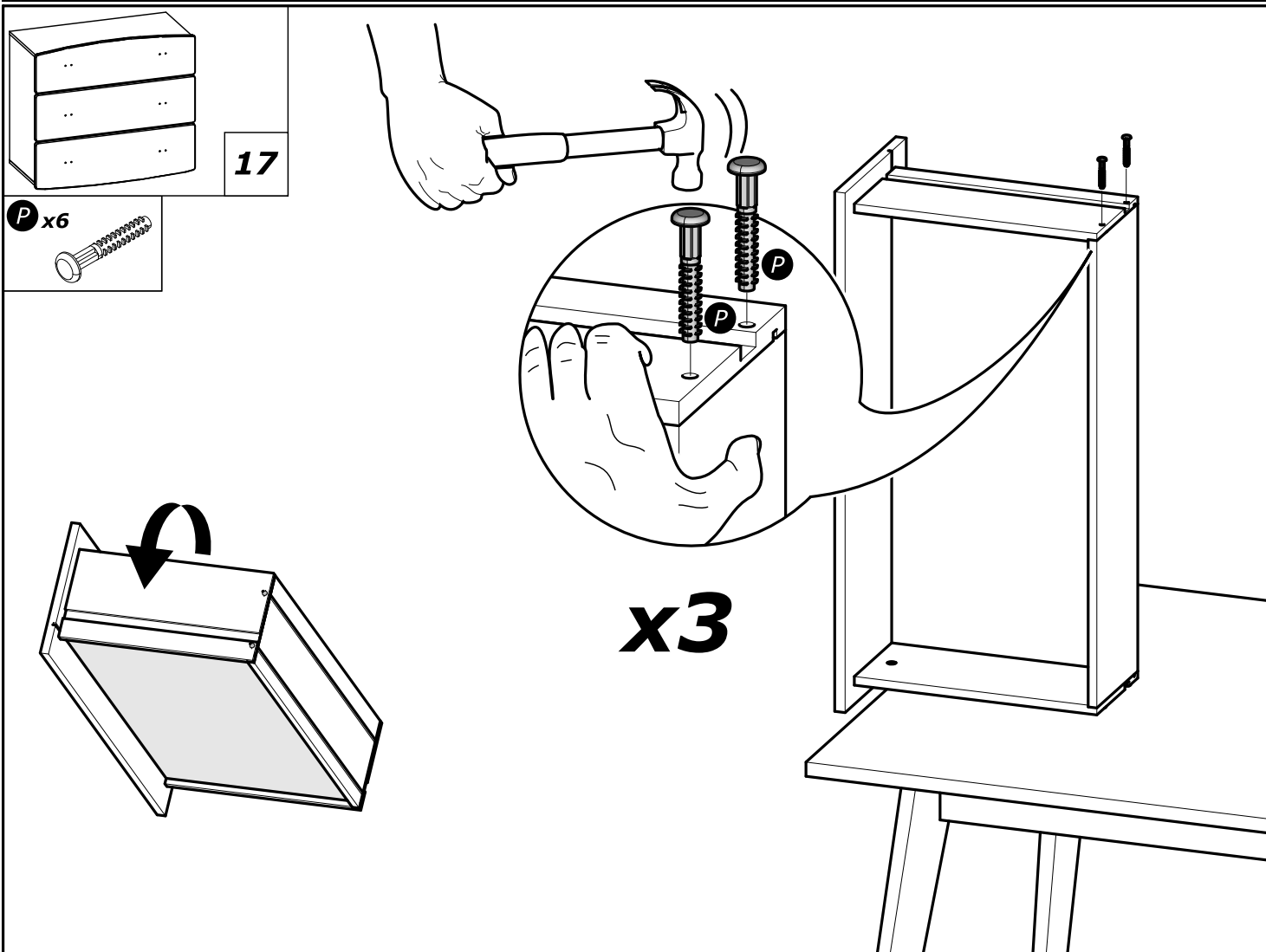
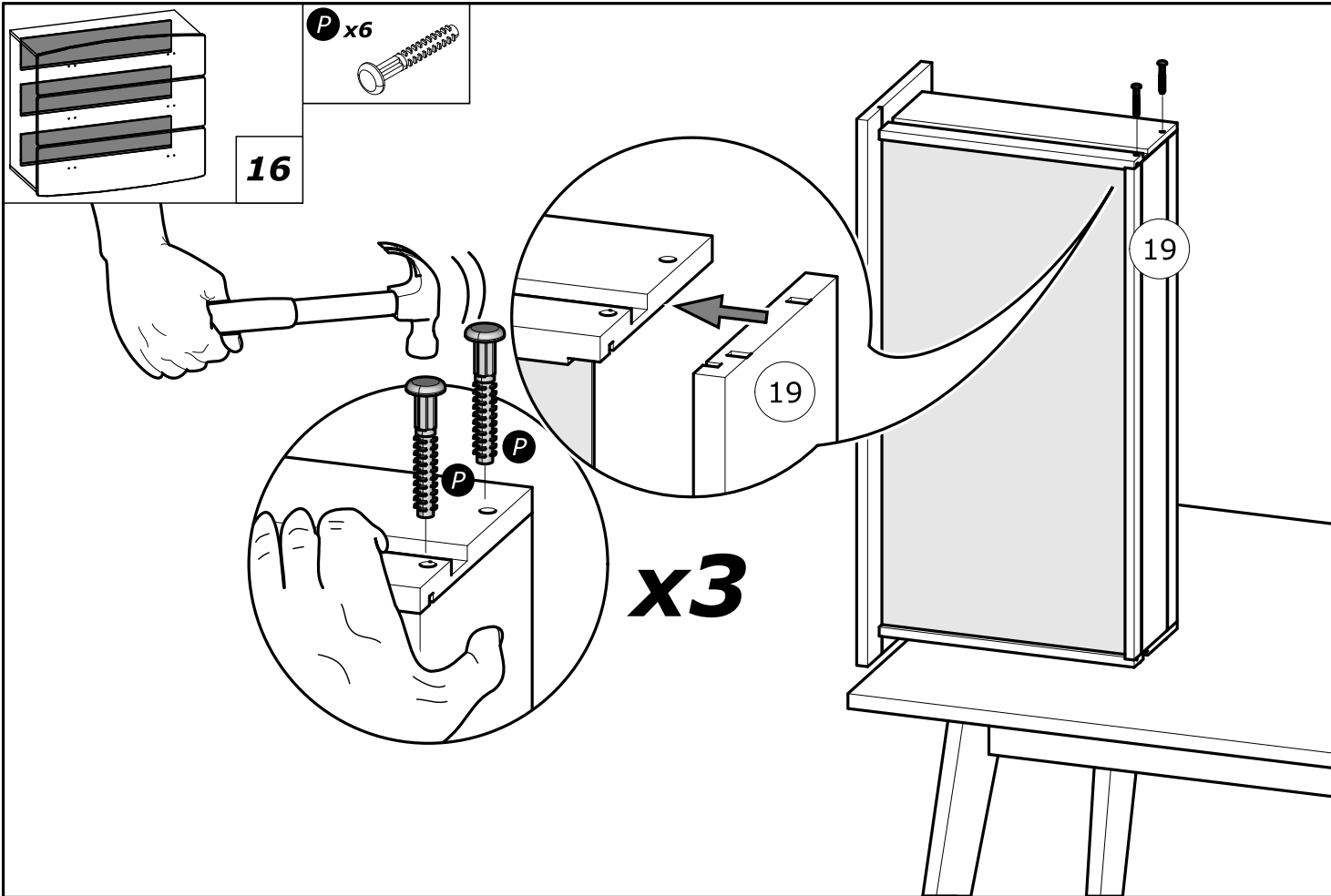

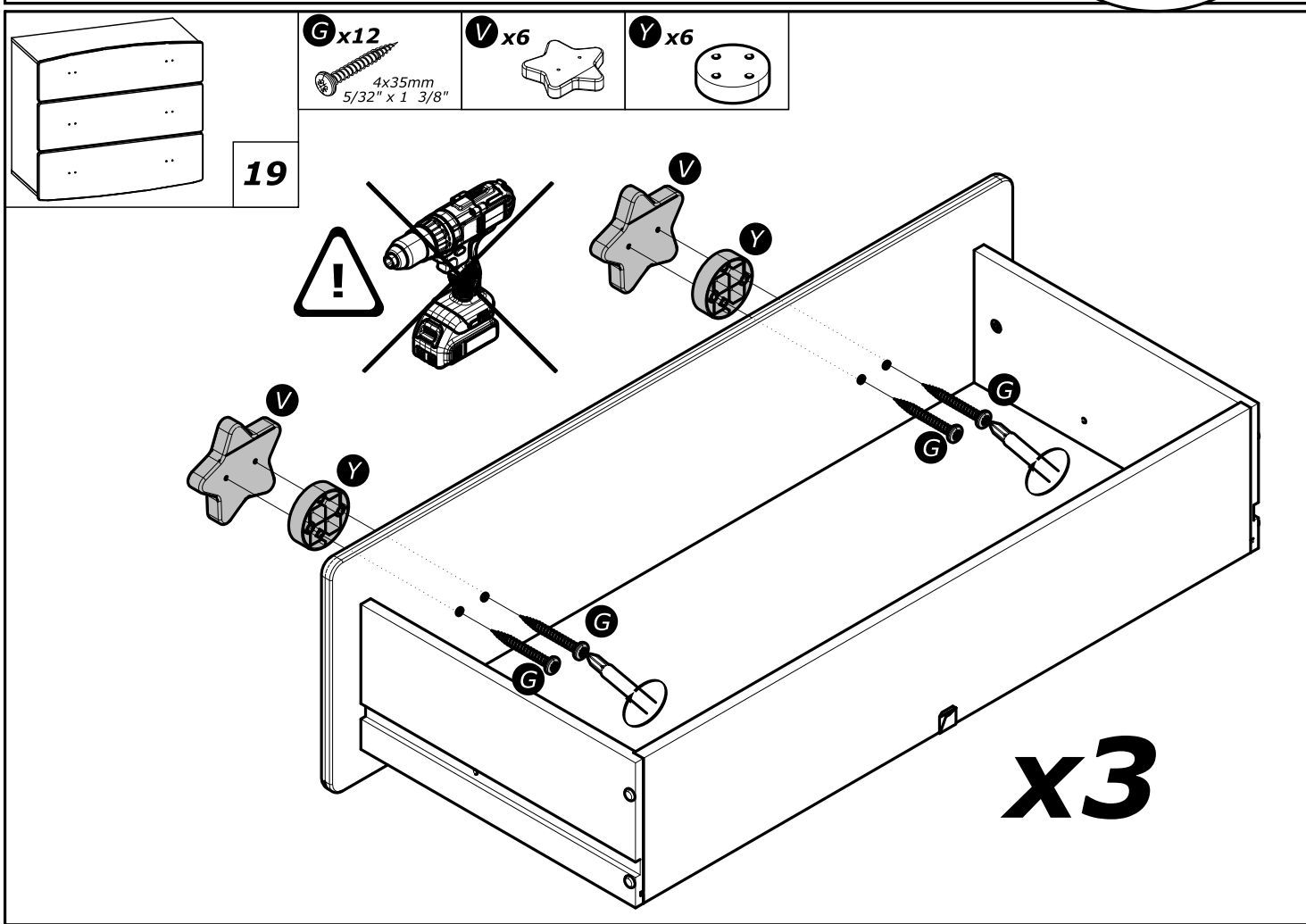
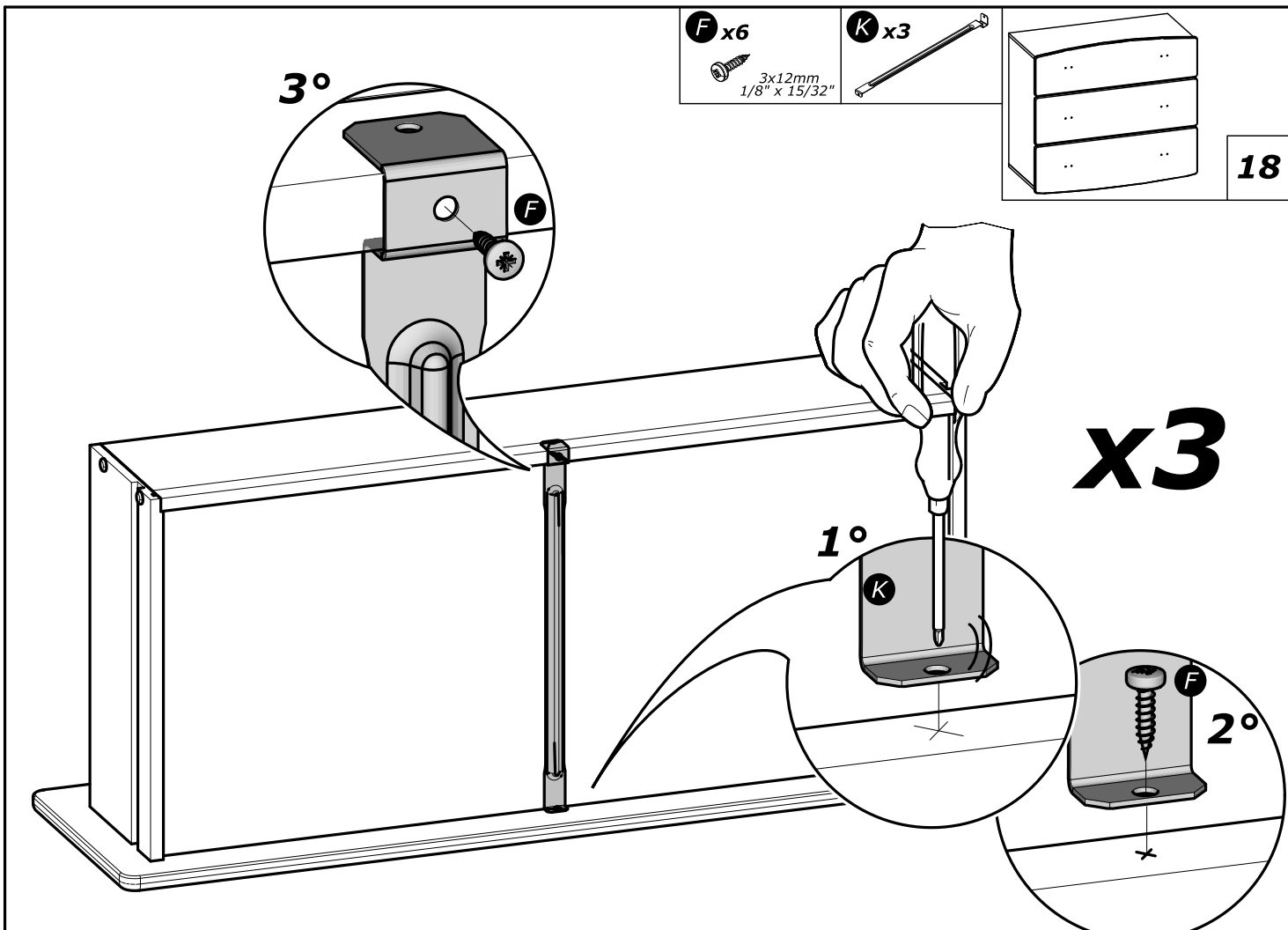

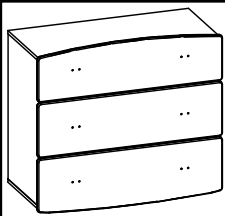

20

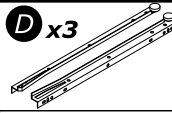

I x12

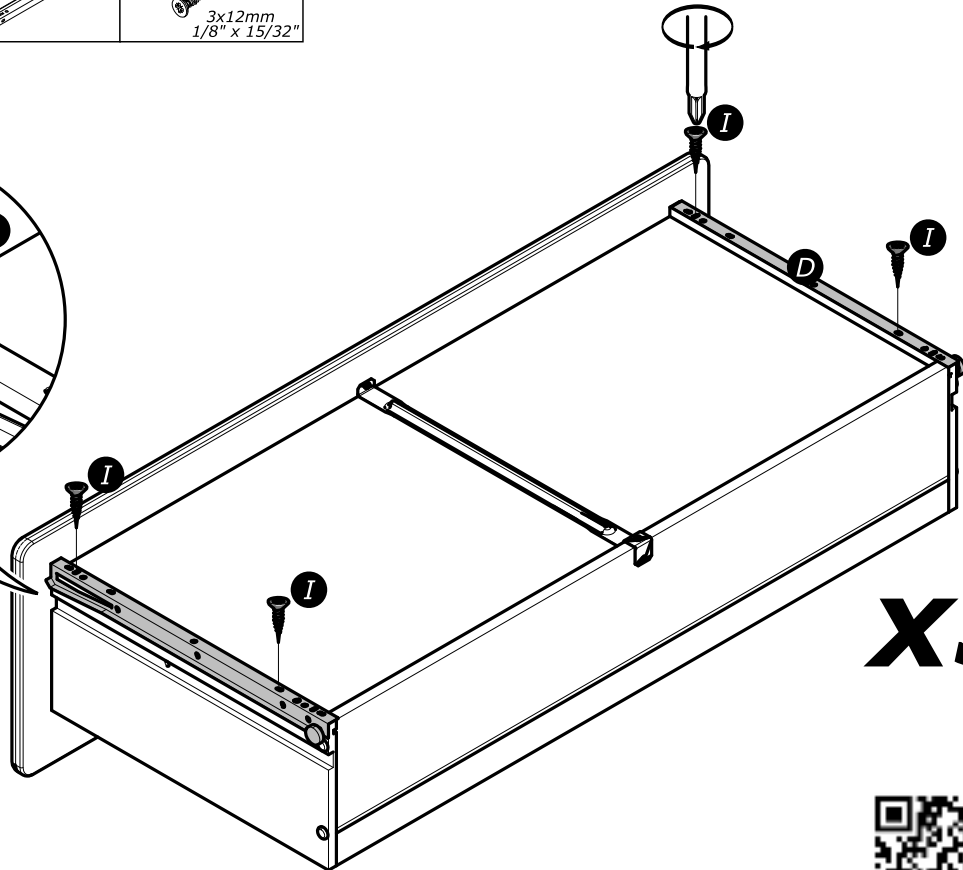
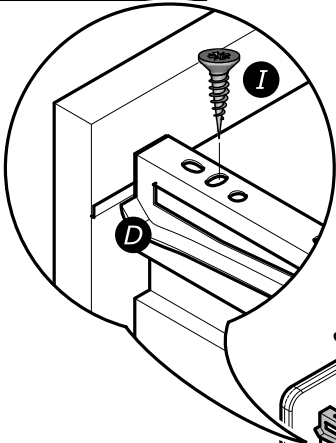
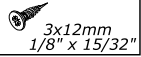

x3



www.Demeyere.fr

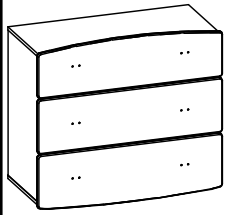

21

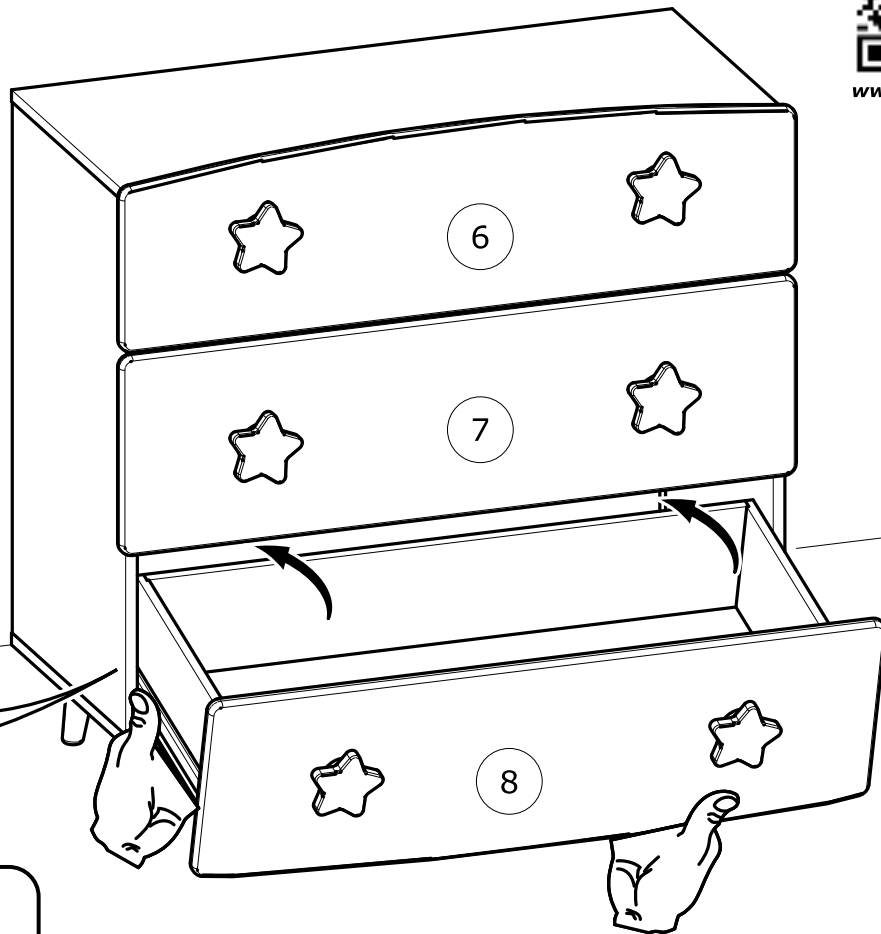
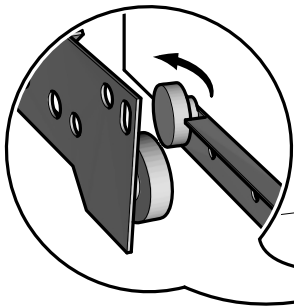

Info tri déchets

www.quefairedemesdechets.fr