

ASSEMBLY INSTRUCTION

SC 84-A

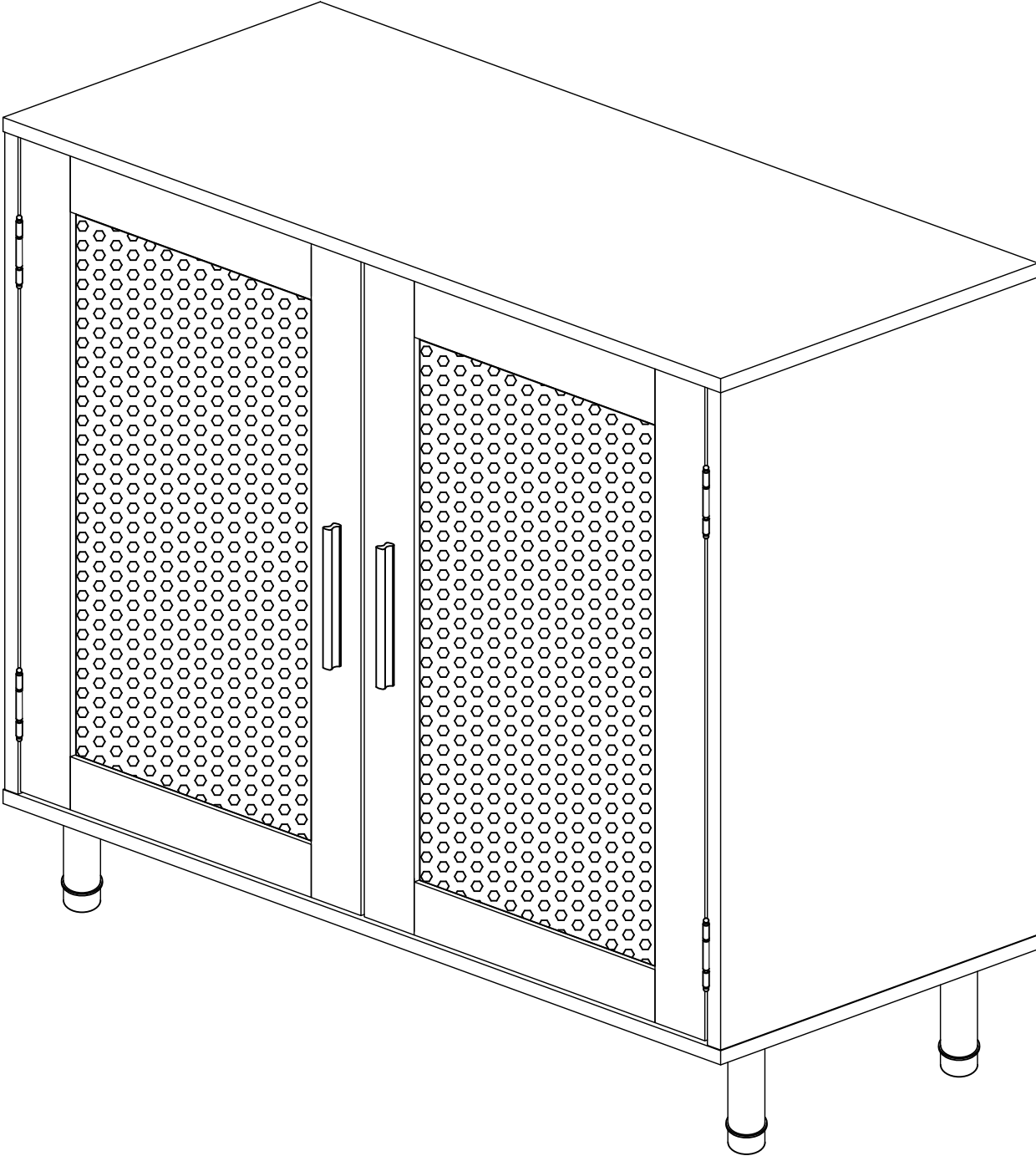





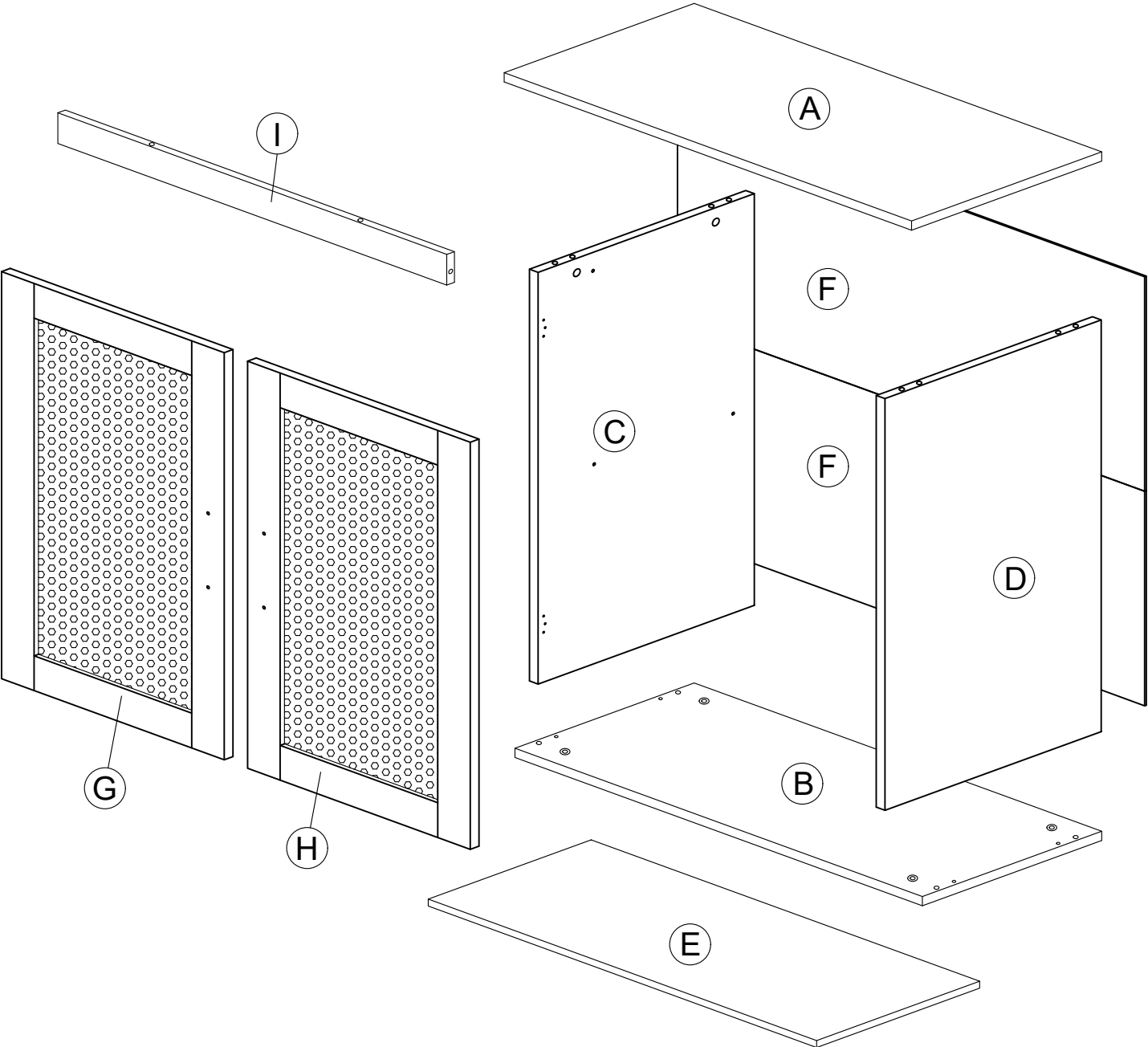



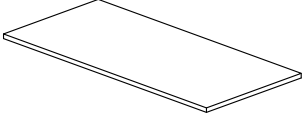
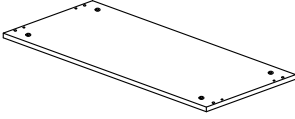

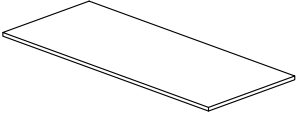
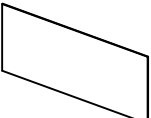
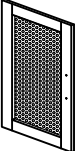
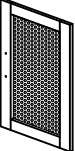
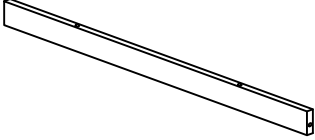

2Doors Shoe Cabinet

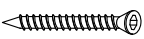

ASSEMBLY INSTRUCTION

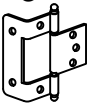

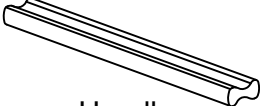
ASSEMBLY INSTRUCTION

PART LIST			
A  Top Panel 1 PC	B  Bottom Panel 1 PC	C  Side Panel L 1 PC	D  Side Panel R 1 PC
E  Shelf Panel 1 PC	F  Back Panel 2 PCS	G  Door Panel L 1 PC	H  Door Panel R 1 PC
I  Top Support LVL 1 PC			
HARDWARE LIST			
1  Camlock 15MM 8 PCS	2  Camlock Bolt 15MM 8 PCS	3  M8x25MM Wood Dowel 8 PCS	4  Nail 5/8 20 PCS
5  CB Screw M3.5x16MM 22 PCS	6  Csk M6x50MM 4 PCS	7  M4x25MM Handle Screw 4 PCS	8  M4 Allen Key 1 PC
9  Hinges 6311-135 4 PCS	10  Sticker 4 PCS	11  Shelf Support 4 PCS	12  Handle 2 PCS
13  Wooden Leg 4 PCS	14  3.5kg Magnet W/ Metal Plate 2 SETS		

ASSEMBLY INSTRUCTION

Step 1

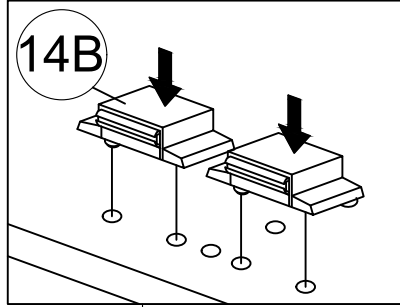
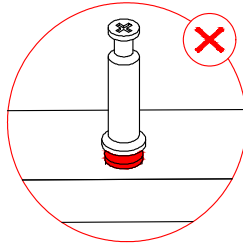
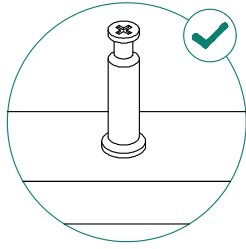
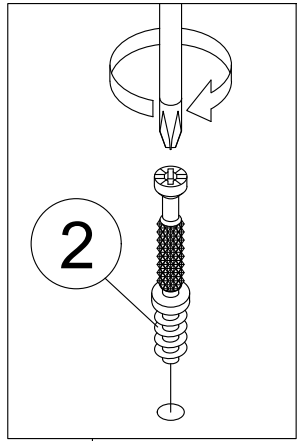

Required/Requis/Requerido

x8



2

x2

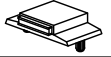

14B

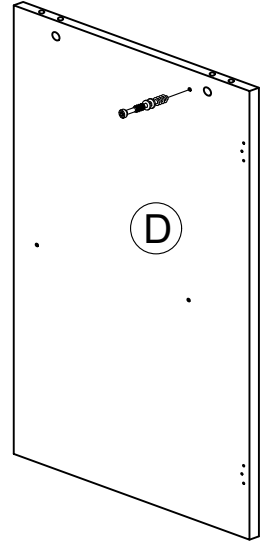
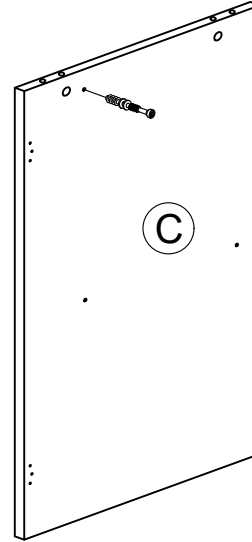
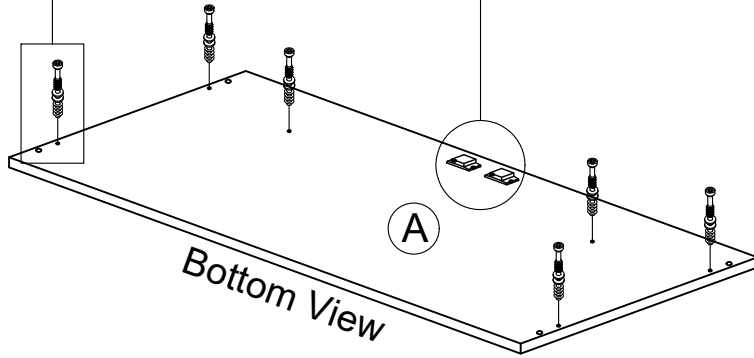

Step 2

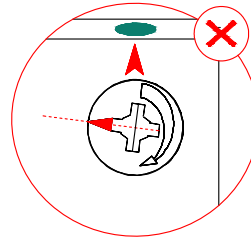
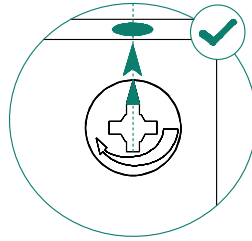
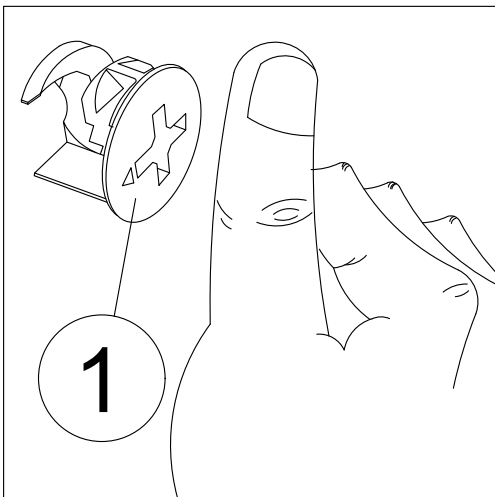

Required/Requis/Requerido

x8



1

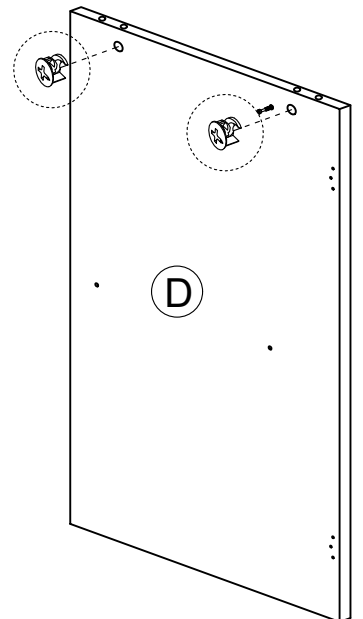
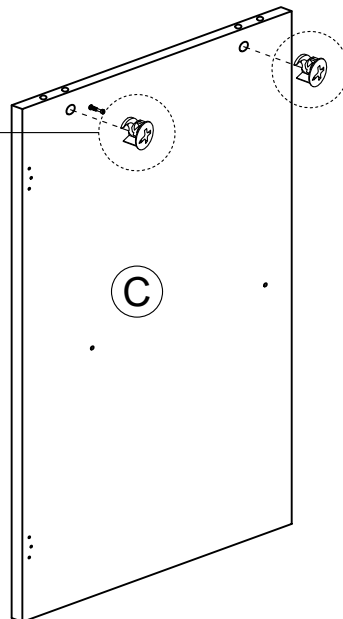
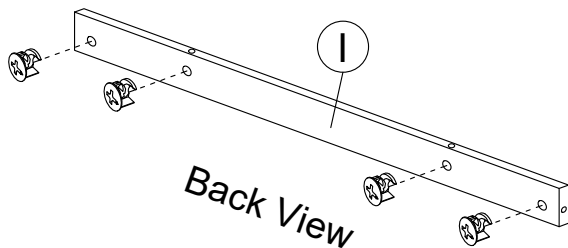

ASSEMBLY INSTRUCTION

Step 3

Required/Requis/Requerido

x8  3

x4  11

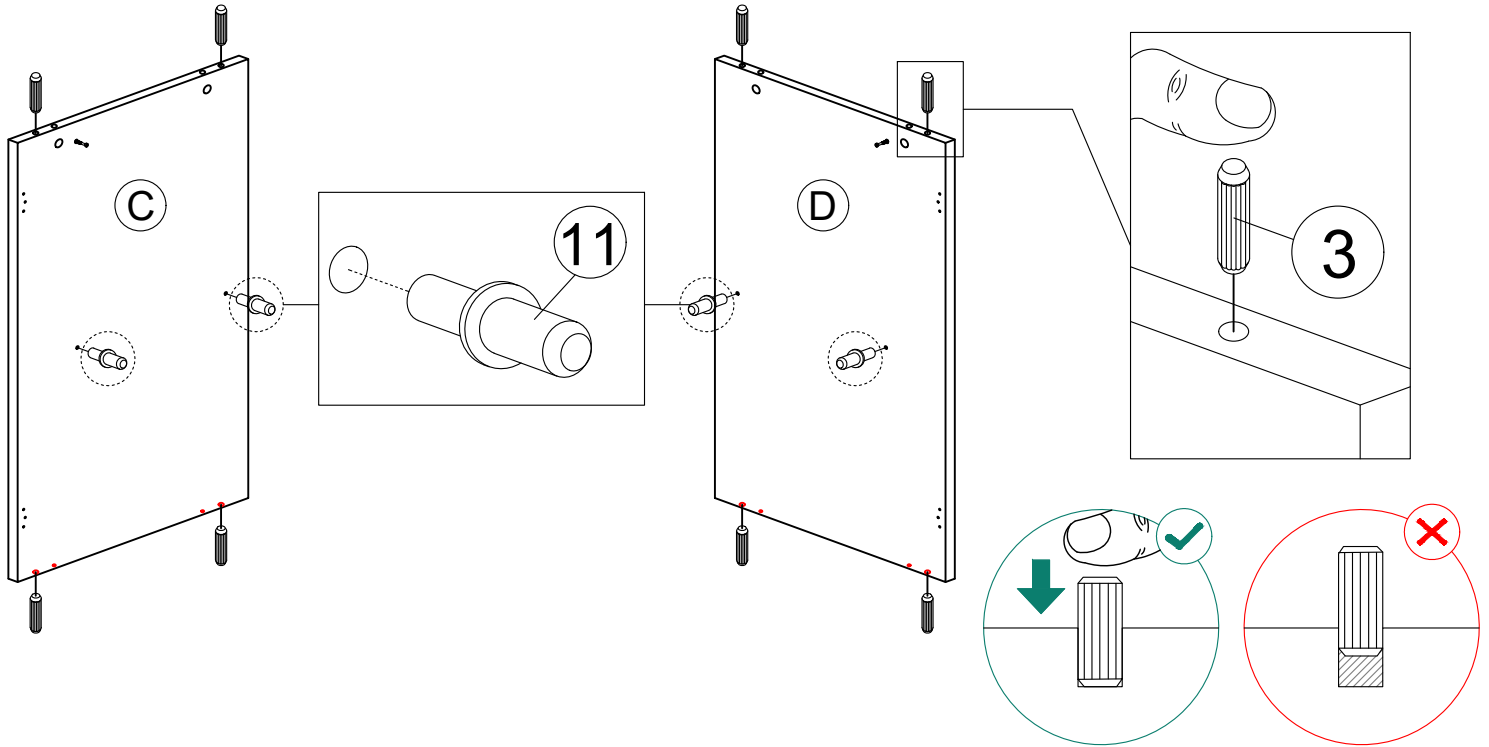

Step 4

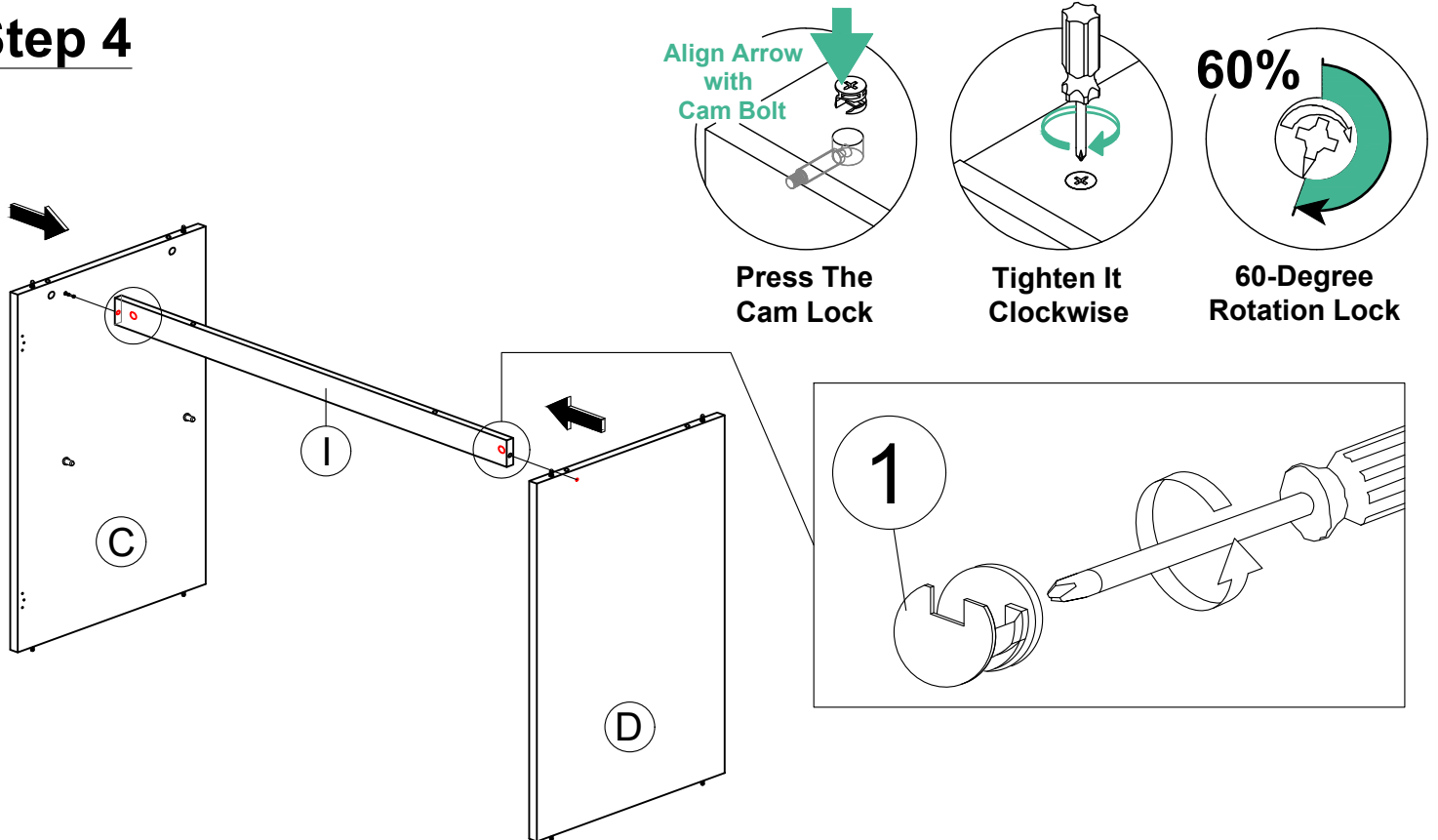

ASSEMBLY INSTRUCTION

Step 5

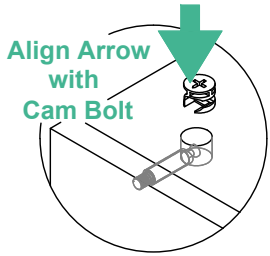
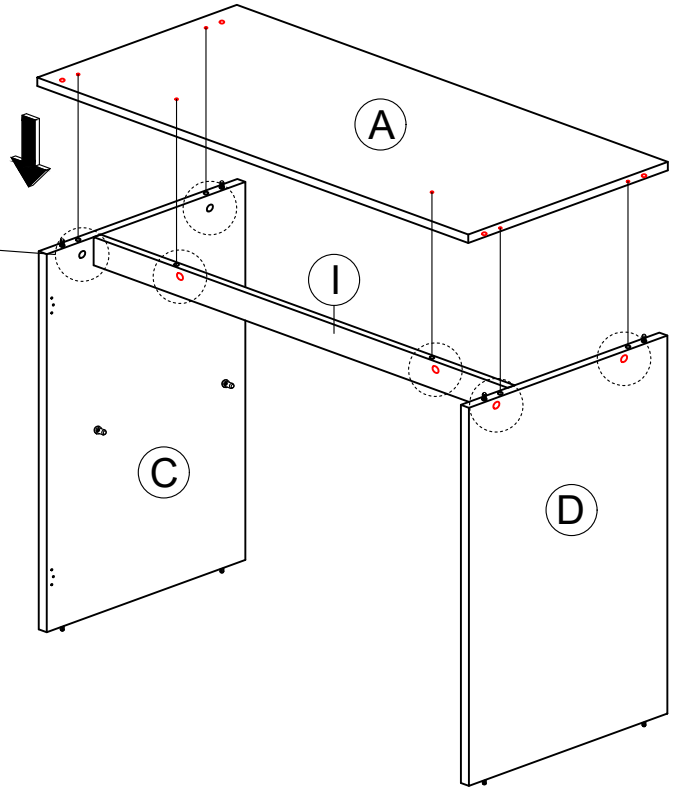
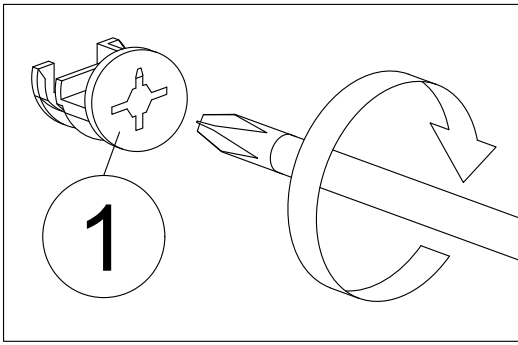

Press The
Cam Lock

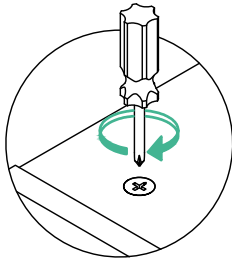

Tighten It
Clockwise

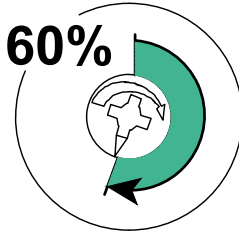

60-Degree
Rotation Lock

Step 6

Required/Requis/Requerido

x1  8

x4  6

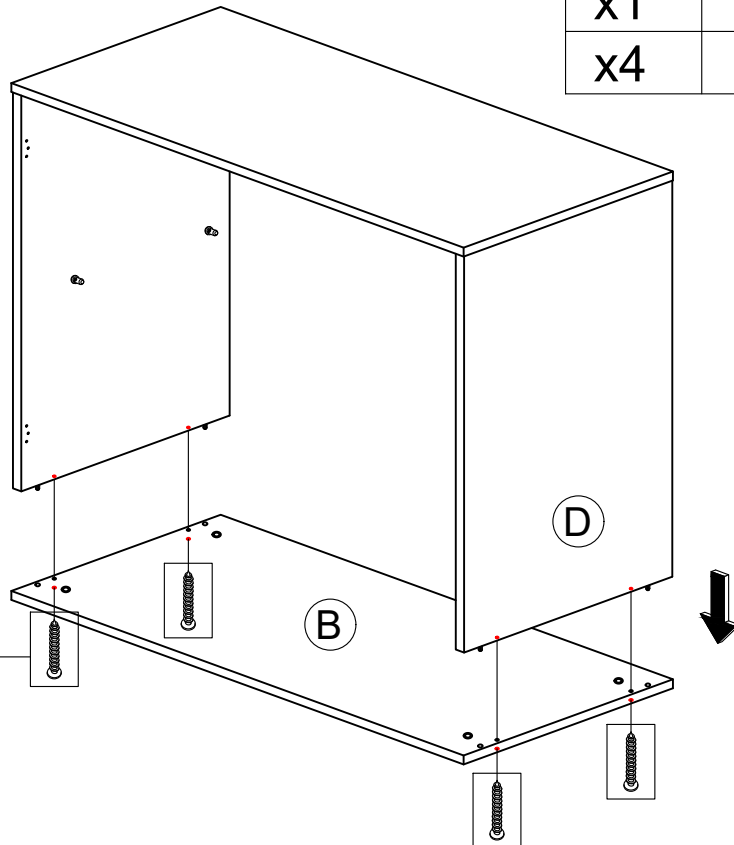
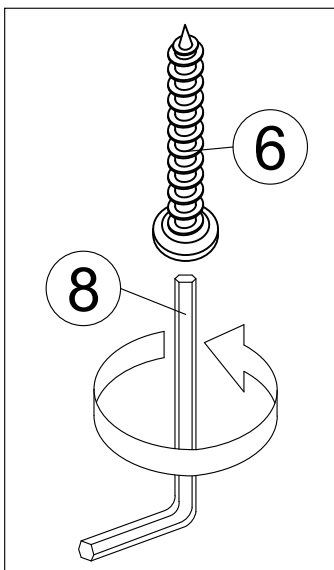

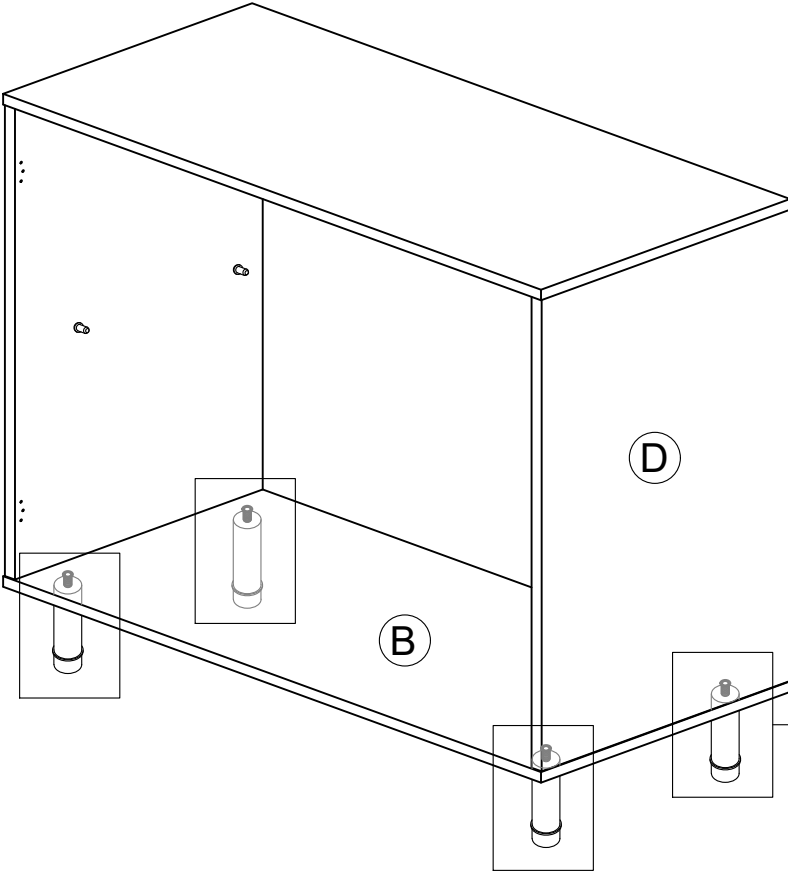

ASSEMBLY INSTRUCTION

Step 7



Required/Requis/Requerido

x4		10
x4		13

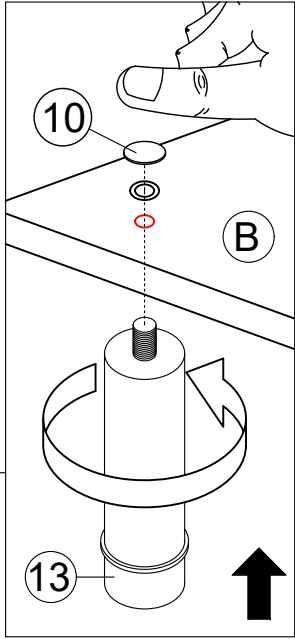

Step 8

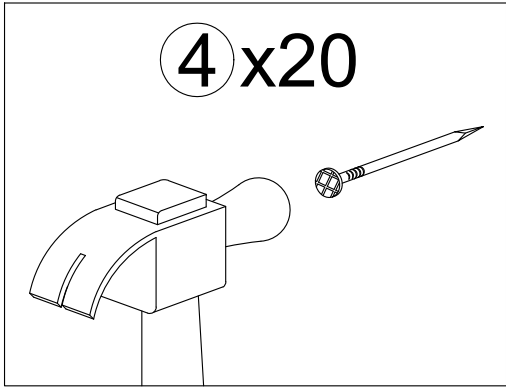

Required/Requis/Requerido

x20		4
-----	---	---

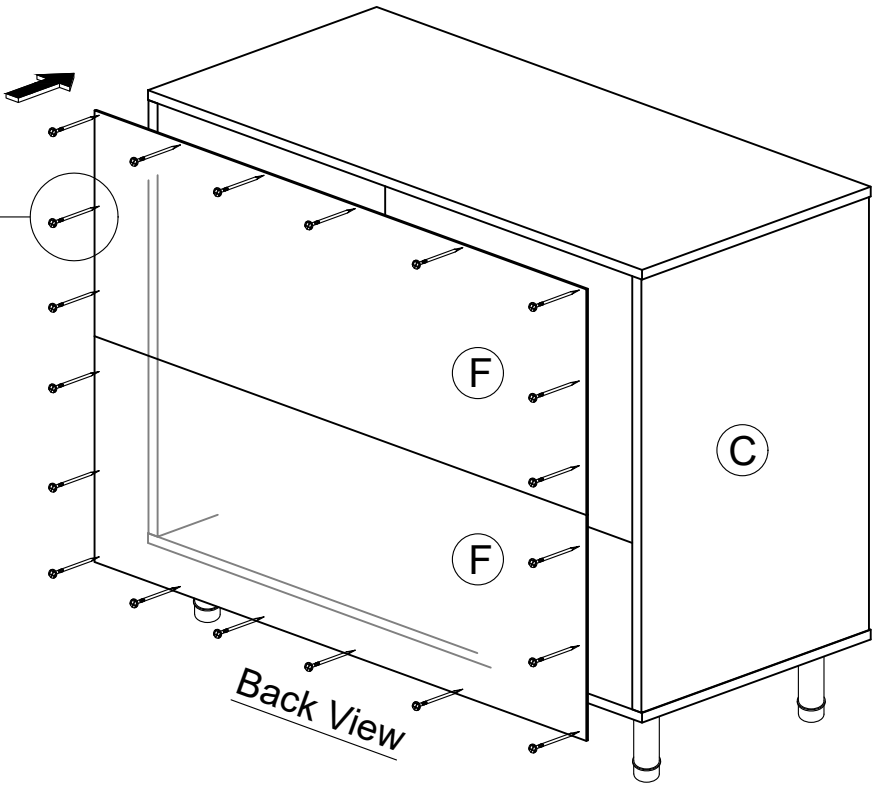

ASSEMBLY INSTRUCTION

Step 9

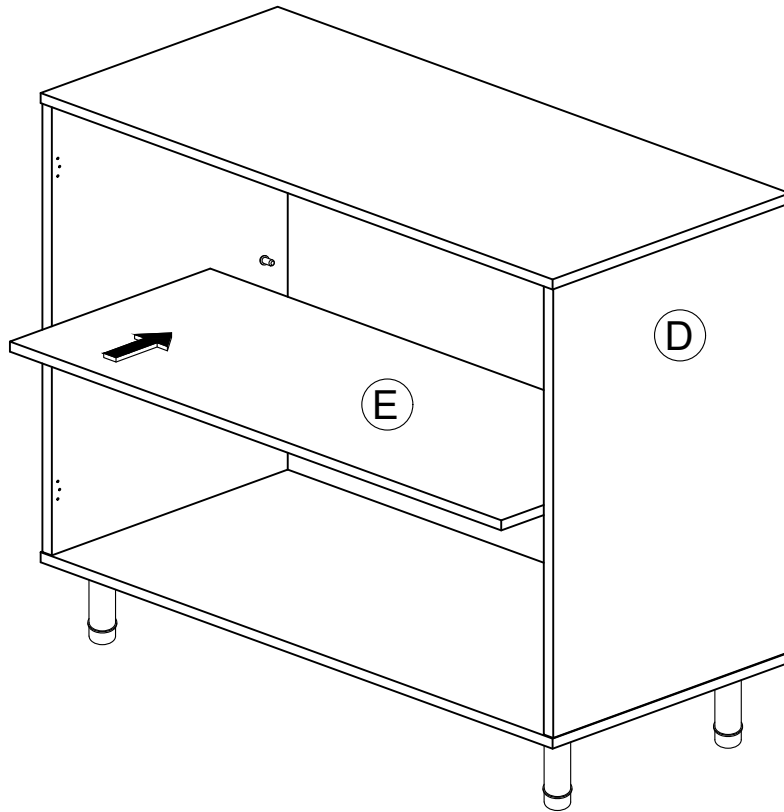

Step 10

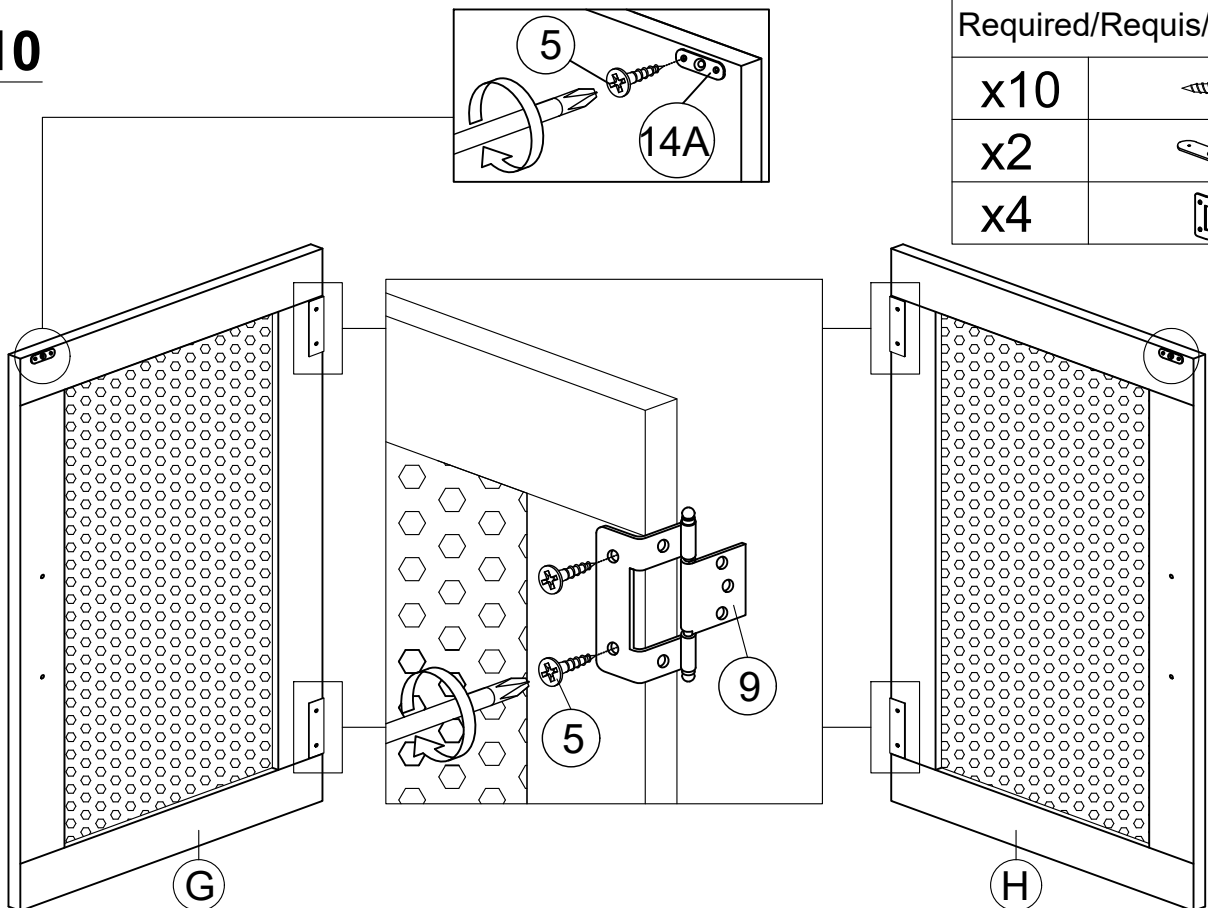

Required/Requis/Requerido

x10  5

x2  14A



x4  9

ASSEMBLY INSTRUCTION

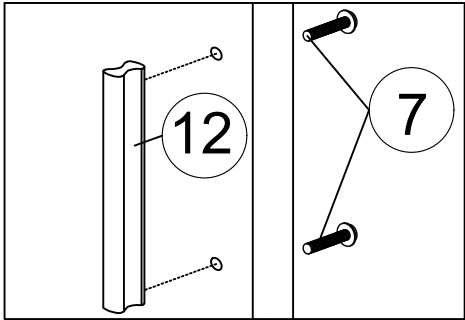
Step 11



Required/Requis/Requerido

x4		7
x2		12

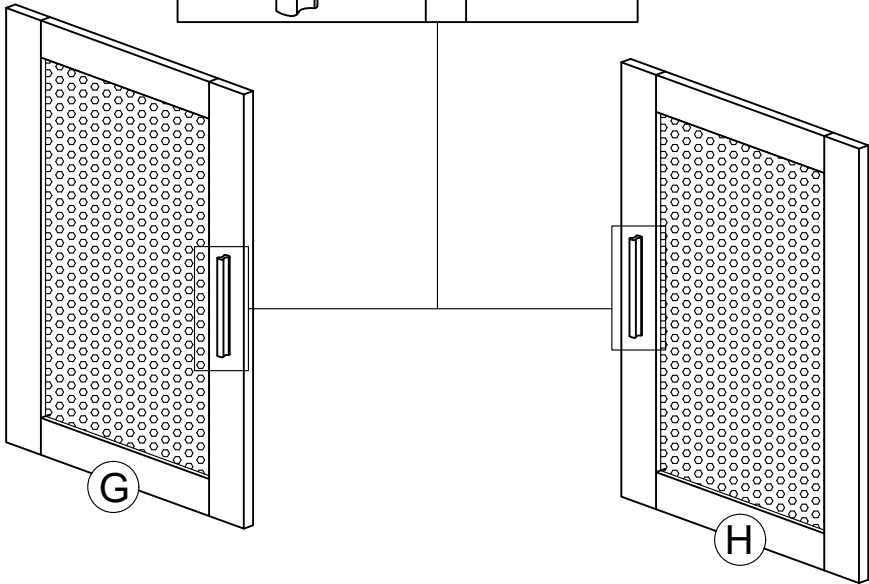

Step 12

Required/Requis/Requerido

x12		5
-----	---	---

