

1542LICO

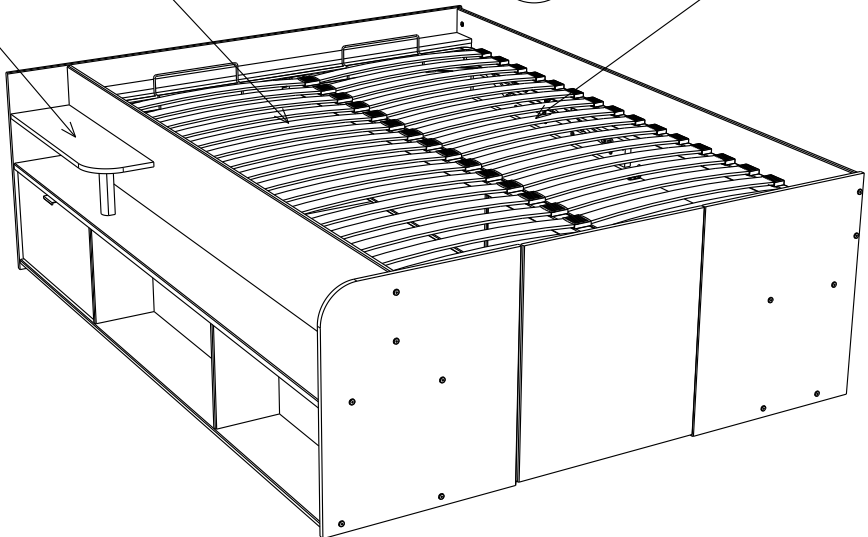

MINI 13Kg / 28.6lb
 MAXI 27Kg / 59.5lb

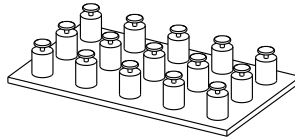
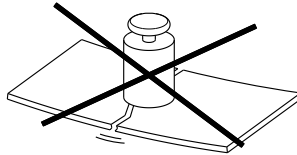
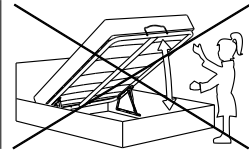
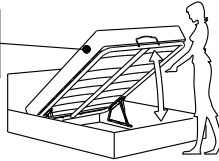

Gamme : TRAVEL

PARISOT INDUSTRIE

FR Remerciements :

Nous vous remercions d'avoir choisi un meuble créé et fabriqué par le Groupe Parisot et espérons qu'il vous donnera entière satisfaction.

EN Thanks:

Thank you for choosing furniture designed and manufactured by the Parisot Group. We hope you are totally satisfied with your purchase.

DE Danksagung:

Wir danken Ihnen für den Kauf eines Frankreich von der Parisot-Gruppe entworfenen und hergestellten Möbelstücks und hoffen, dass Sie es zu Ihrer vollkommenen Zufriedenheit finden werden.

HU Köszönet:

Köszönjük, hogy a Parisot Groupe által létrehozott és gyártott bútort választott, reméljük, hogy elégedett lesz a termékkel.

PT Agradecimentos:

Obrigado por ter escolhido um móvel concebido e fabricado pelo Grupo Parisot, esperando que seja do seu inteiro agrado.

IT Ringraziamenti:

Grazie per avere scelto un mobile progettato e fabbricato dal Gruppo Parisot. Speriamo soddisfi appieno le vostre esigenze.

NL Bedankje:

Wij bedanken u voor de aankoop van een door de Groep Parisot ontworpen en vervaardigd meubel en hopen dat u er veel plezier aan zult beleven.

CZ Poděkování:

Děkujeme, že jste si vybrali nábytek navržený a vyrobený společností Parisot Group. Doufáme, že budete svým nákupem naprosto spokojeni.

ES Agradecimientos:

Les damos las gracias por haber elegido un mueble diseñado y fabricado por el Groupe Parisot y esperamos que sea de su total agrado.

PL Podziękowania:

Dziękujemy za wybór mebli stworzonych i wyprodukowanych przez Grupę Parisot. Mamy nadzieję, że będziecie Państwo w pełni zadowoleni z zakupu.

SK Pod'akovanie:

Ďakujeme, že ste si vybrali nábytok navrhnutý a vyrobený spoločnosťou Parisot Group. Dúfame, že budete svojim nákupom absolútne spokojní.

AR شكر:

نشكركم لاختياركم هذه القطعة من الأثاث من تصميم وتصنيع مجموعة باريزو Parisot ونتمنى أن تنال رضاكم.

PARISOT INDUSTRIE

15 Avenue Jacques Parisot, 70800 Saint-Loup sur Semouse
contact@parisot.com
RCS VESOUL 537 665 200

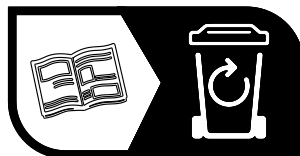
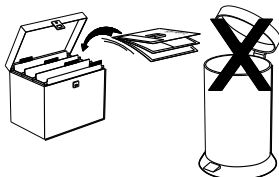

FR

Donnez ou recyclez
vos meubles.



Association



Magasin



Déchèterie

<https://quefairedemesdechets.fr>

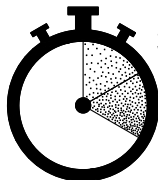
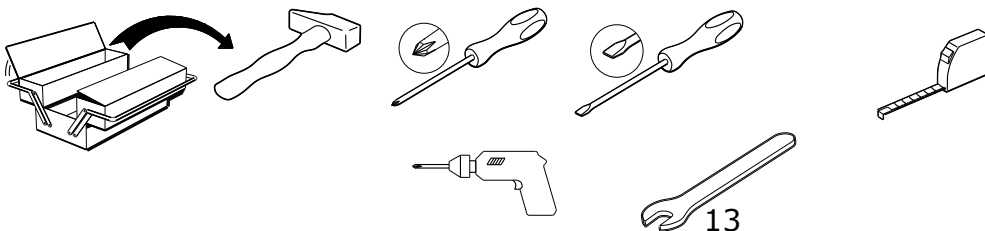

3h 15'

6h 30'

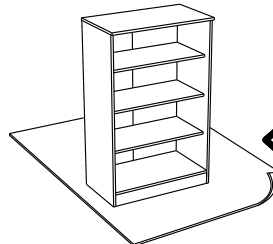
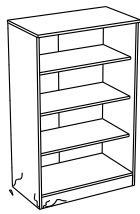

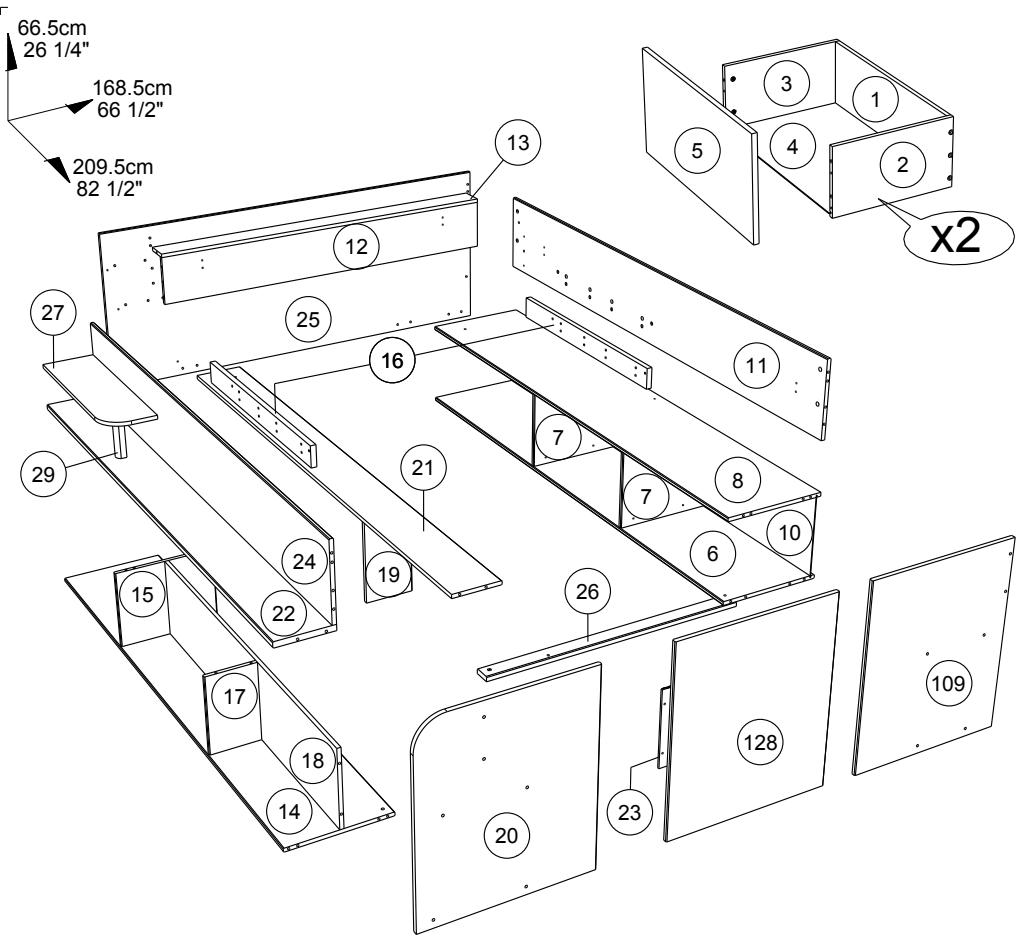

		mm			inch		
29	x 1	150	44	35	5 7/8	1 3/4	1 3/8
23	x 1	256	40	6	10 1/16	1 9/16	1/4
19	x 1	308	179	15	12 1/8	7 1/16	9/16
17	x 1	308	193	15	12 1/8	7 5/8	9/16
7	x 2	374	308	15	14 3/4	12 1/8	9/16
15	x 1	387	308	15	15 1/4	12 1/8	9/16
5	x 2	600	297	15	23 5/8	11 11/16	9/16
128	x 1	654	565	15	25 3/4	22 1/4	9/16
109	x 1	662	545	15	26 1/16	21 7/16	9/16
20	x 1	662	568	15	26 1/16	22 3/8	9/16
27	x 1	664	198	15	26 1/8	7 13/16	9/16
26	x 1	1000	60	19	39 3/8	2 3/8	3/4
18	x 1	1444	308	15	56 7/8	12 1/8	9/16
13	x 1	1449	98	15	57 1/16	3 7/8	9/16
12	x 1	1449	199	15	57 1/16	7 13/16	9/16

		mm			inch		
25	x 1	1683	665	15	66 1/4	26 3/16	9/16
21	x 1	2065	184	15	81 5/16	7 1/4	9/16
22	x 1	2065	213	22	81 5/16	8 3/8	7/8
24	x 1	2065	295	15	81 5/16	11 5/8	9/16
11	x 1	2065	302	15	81 5/16	11 7/8	9/16
6	x 1	2065	397	15	81 5/16	15 5/8	9/16
14	x 1	2065	397	15	81 5/16	15 5/8	9/16
8	x 1	2065	397	15	81 5/16	15 5/8	9/16
2	x 2	350	196	13	13 3/4	7 11/16	1/2
3	x 2	350	196	13	13 3/4	7 11/16	1/2
5	x 2	556	196	13	21 7/8	7 11/16	1/2
4	x 2	568	349	3	22 3/8	13 3/4	1/8
10	x 1	2064	323	3	81 1/4	12 11/16	1/8

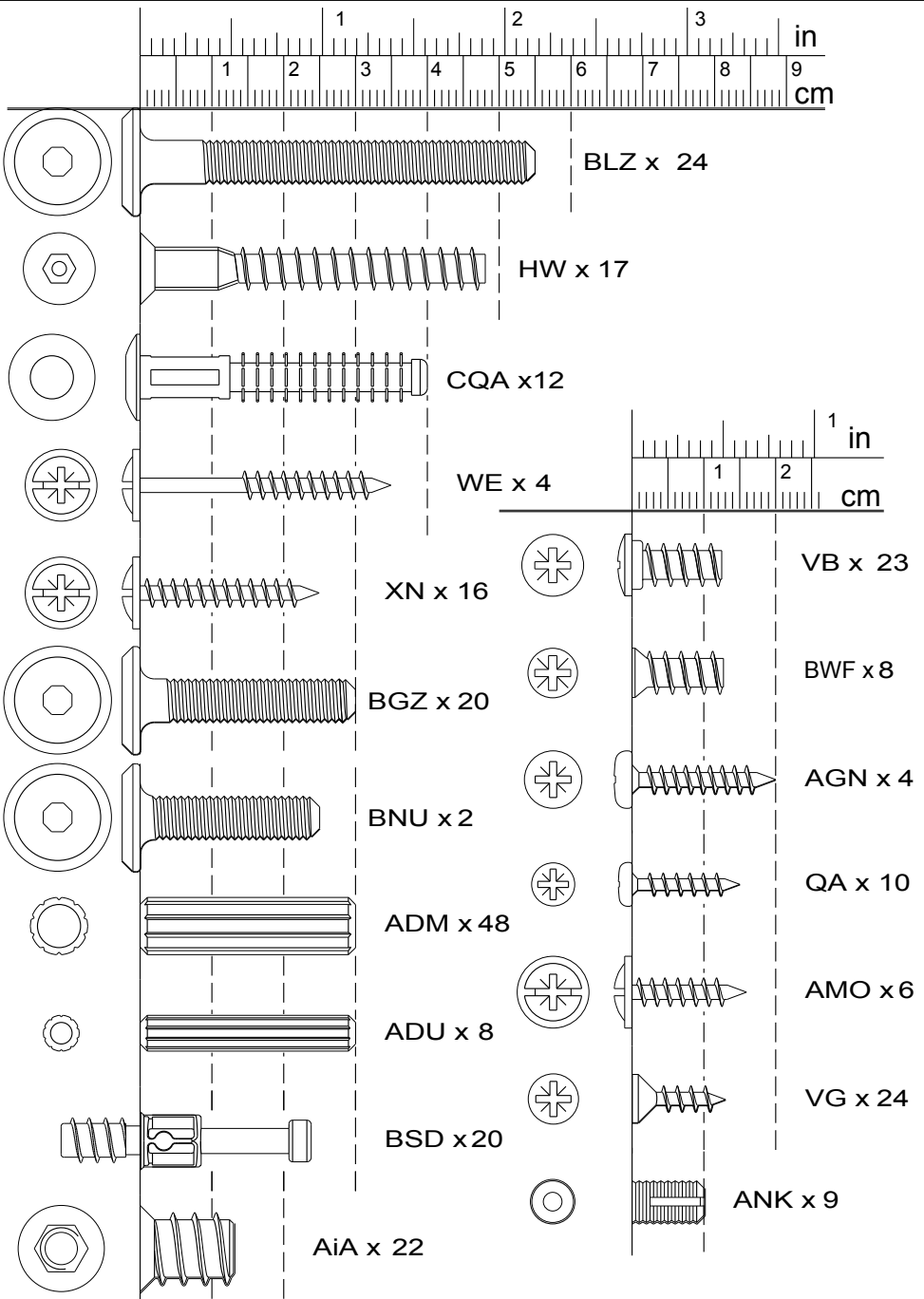

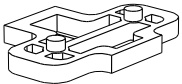

ANN x 2



AHX x 24

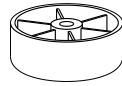

BXC x 16



Ai x 12



BZG x 8

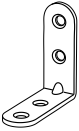

LN x 4



EP x 8

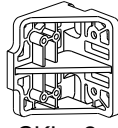

CKL x 2



EO x 2

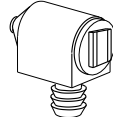

YI x 1



YJ x 1



AHZ x 1



BLR x 4



HV x 1

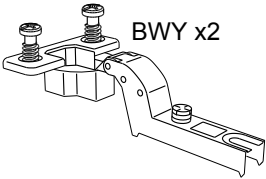

BWY x 2

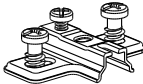

BWU x 2



BAG x 7

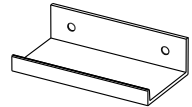

POI x 2

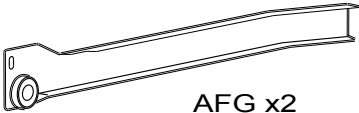

AFG x 2

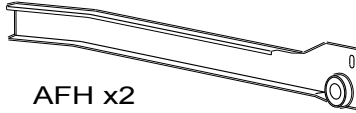

AFH x 2

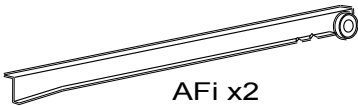

AFi x 2

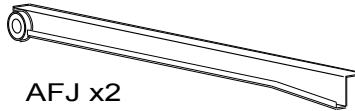

AFJ x 2

FR: INSTRUCTIONS GÉNÉRALES POUR LE MOBILIER CONSTITUÉ DE BOIS OU DE COMPOSITES DE BOIS (COMME LES SURFACES EN MELAMINÉ, STRATIFIÉ OU PLACAGE)

Nettoyer à l'aide d'un chiffon humide. Utiliser uniquement de l'eau ou un détergent doux.

Essuyer à l'aide d'un chiffon propre.

Pour une stabilité optimale, resserrer les vis et autres fixations lorsque nécessaire.

EN: GENERAL INSTRUCTION FOR FURNITURE MADE OF WOOD OR WOOD COMPOSITES SUCH AS MELAMINE, LAMINATE OR VENEER SURFACES

Wipe clean with a damp cloth. Use only water or a gentle detergent.

Wipe dry with a clean cloth.

For increased stability, re-tighten the screws and other connectors when necessary.

DE: ALLGEMEINE ANWEISUNGEN FÜR MÖBELPFLEGE AUS HOLZ ODER HOLZVERBUNDWERKSTOFFEN (WIE MELAMIN-, LAMINA T- ODER FURNIEROBERFLÄCHEN)

Mit einem feuchten Tuch reinigen. Verwenden Sie nur Wasser oder ein mildes Reinigungsmittel.

Mit einem sauberen Tuch abwischen.

Zur Erhöhung der Stabilität die Schrauben und anderen Verbindungsstücke bei Bedarf nachziehen.

HU: ÁLTALÁNOS ÚTMUTATÁS A FÁBÓL KÉSZÜLT VAGY ÖSSZETETT FAANYAGOT, PÉLDÁUL MELAMIN-, LAMINÁLT VAGY FURNÉRFELÜLETET TARTALMAZÓ BÚTOROKHOZ

Törölje tisztára nedves ruhával. Csak vizet vagy kímélő tisztítószeret használjon.

Törölje szárazra tiszta ruhával.

A nagyobb stabilitás érdekében szükség esetén húzd meg újra a csavarokat és egyéb összekötő elemeket.

PT: INSTRUÇÕES GERAIS PARA OS MOVÉIS DE MADEIRA, LAMINADO, MELAMINA E FOLHEADO.

Limpar com um pano húmido, utilizar apenas água ou detergente doce.

Limpar com um pano seco.

Para uma maior estabilidade, volte a apertar os parafusos e outros conetores sempre que necessário.

IT: ISTRUZIONI GENERALI PER MOBILI IN LEGNO O MATERIALI COMPOSITI IN LEGNO (COME SUPERFICI IN MELAMINICO, LAMINATO O IMPIALLACCIATO)

Pulire con un panno umido. Utilizzare solo acqua o un detergente delicato.

Asciugare con un panno pulito.

Per una maggiore stabilità, stringi nuovamente le viti e gli altri elementi di fissaggio quando necessario.

NL: ALGEMENE INSTRUCTIES VOOR MEUBELS VERVAARDIGD UIT HOUT OF HOUTCOMPOSITIE ALS MELAMINE, LAMINAAT OF FINEEROPPERVLAKKEN!

Reinig met een vochtige doek. Gebruik alleen water of wasmiddel.

Droogwrijven met een schone doek.

Voor extra stevigheid de schroeven en andere verbindingen nogmaals aandraaien wanneer nodig.

CZ: OBEČNÉ POKYNY TÝKAJÍCÍ SE NÁBYTKU VYROBENÉHO ZE DŘEVA NEBO Z KOMPOZITŮ DŘEVA, NAPŘ. S POUŽITÍM MELAMINU, LAMINÁTU NEBO DÝHY!

Čistěte otřením navlhčeným hadříkem. Používejte pouze vodu nebo jemný čistící prostředek.

Vytřete dosucha čistým hadříkem.

Pro zvýšení stability šrouby a další spojovací díly v případě potřeby dotáhněte.

ES: INSTRUCCIONES GENERALES PARA MUEBLES FABRICADOS CON MADERA, MELAMINA, LAMINADO Y CHAPA.

Limpiar con pano húmedo. Utilizar únicamente agua o detergente suave.

Secar con un paño seco.

Para mayor estabilidad, aprieta de nuevo los tornillos y otros conectores cuando sea necesario.

PL: OGÓLNE INSTRUKCJE DOTYCZĄCE MEBLI Z DREWNA ORAZ MATERIAŁÓW DREWNOPOCHODNYCH : MELAMINA, LAMINAT, OKLEINA

Do czyszczenia należy używać wilgotnej ściereczki. Używać wyłącznie wody lub delikatnego detergentu.

Wycierać do sucha ściereczką.

Aby uzyskać optymalną stabilność, w razie potrzeby dokręć śruby i inne elementy mocujące.

SK: VŠEOBECNÉ POKYNY PRE NÁBYTOK VYROBENÝ Z DREVA ALEBO KOMPOZITNÝCH MATERIÁLOV, NAPRIKLAD MELAMINU, LAMINÁTU ALEBO PREGLEJKOVÝCH POVRCHOV!

Utrite dočista navlhčenou utierkou. Používajte iba vodu alebo jemný čistiaci prostriedok.

Utrite dosucha čistou utierkou.

Na zvýšenie stability v prípade potreby opätovne utiahnite skrutky a ostatné spojovacie prvky.

AR: تعليمات عامة للأثاث المصنوع من الخشب أو الخشب المركبات مثل الميلامين أو الصفانج أو الأسطح الخشبية

امسحي بقطعة قماش مبللة. استخدم الماء أو المنظف اللطيف فقط. يجف بقطعة قماش نظيفة.

لمزيد من الثبات، أعد ربط المسامير والوصلات الأخرى عند الضرورة.

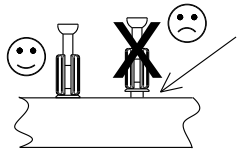
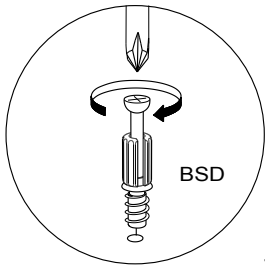
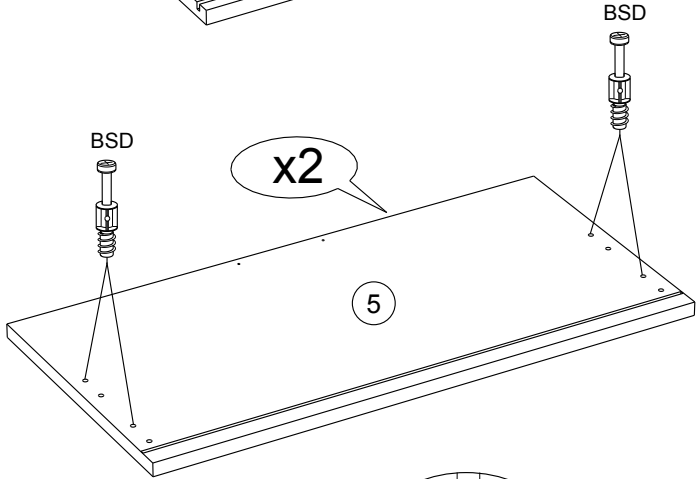
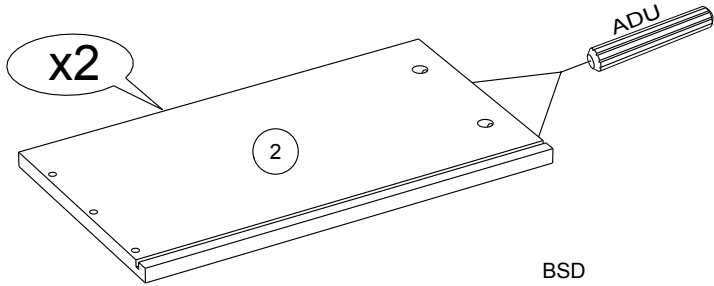
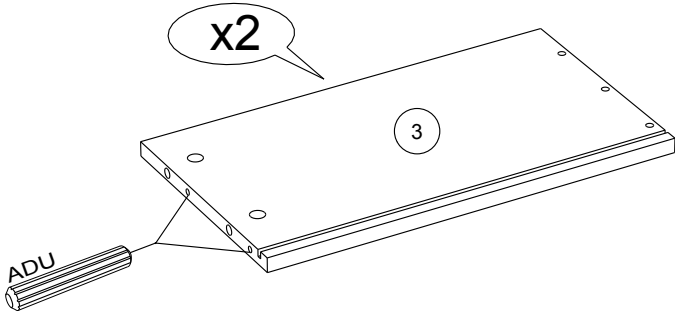
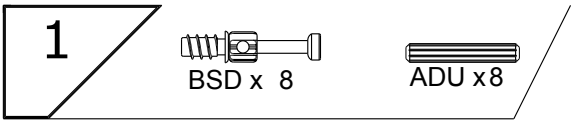

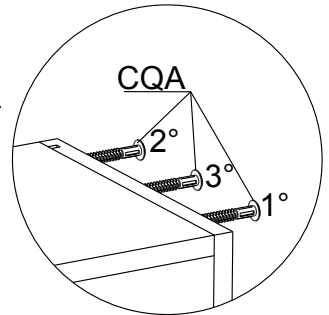
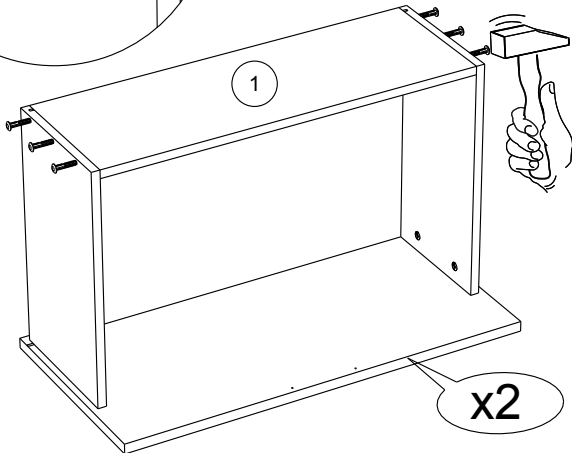
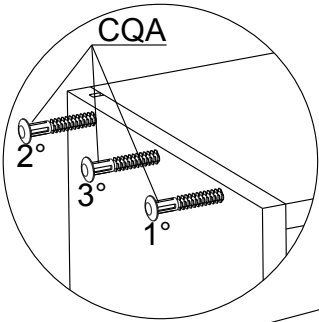
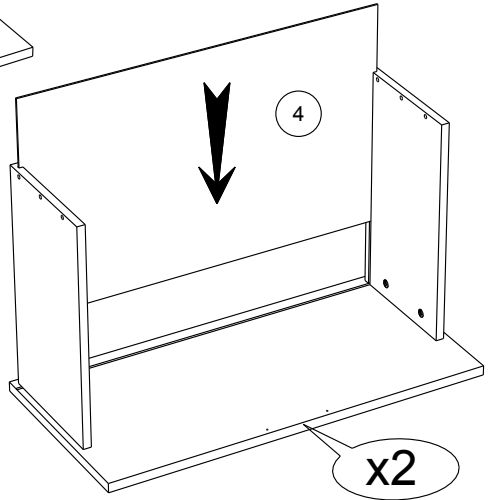
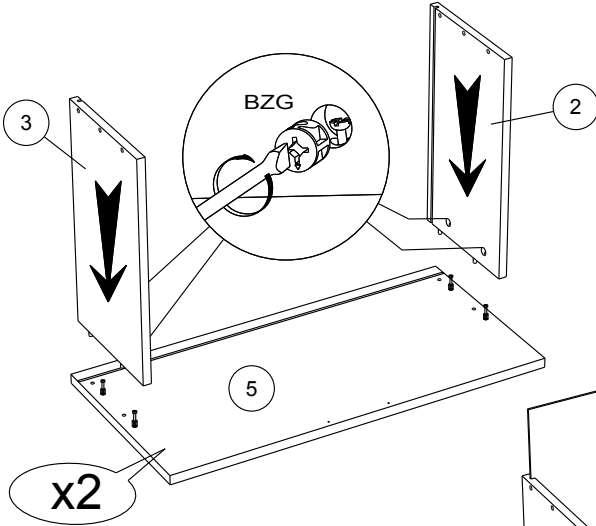
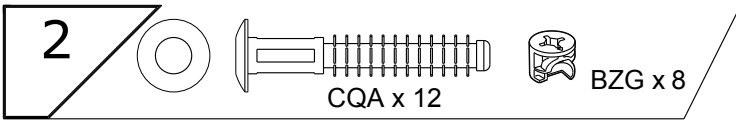

3



AFi x 2

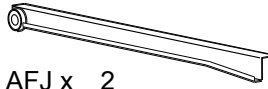

AFJ x 2

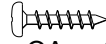

QA x 8



EP x4

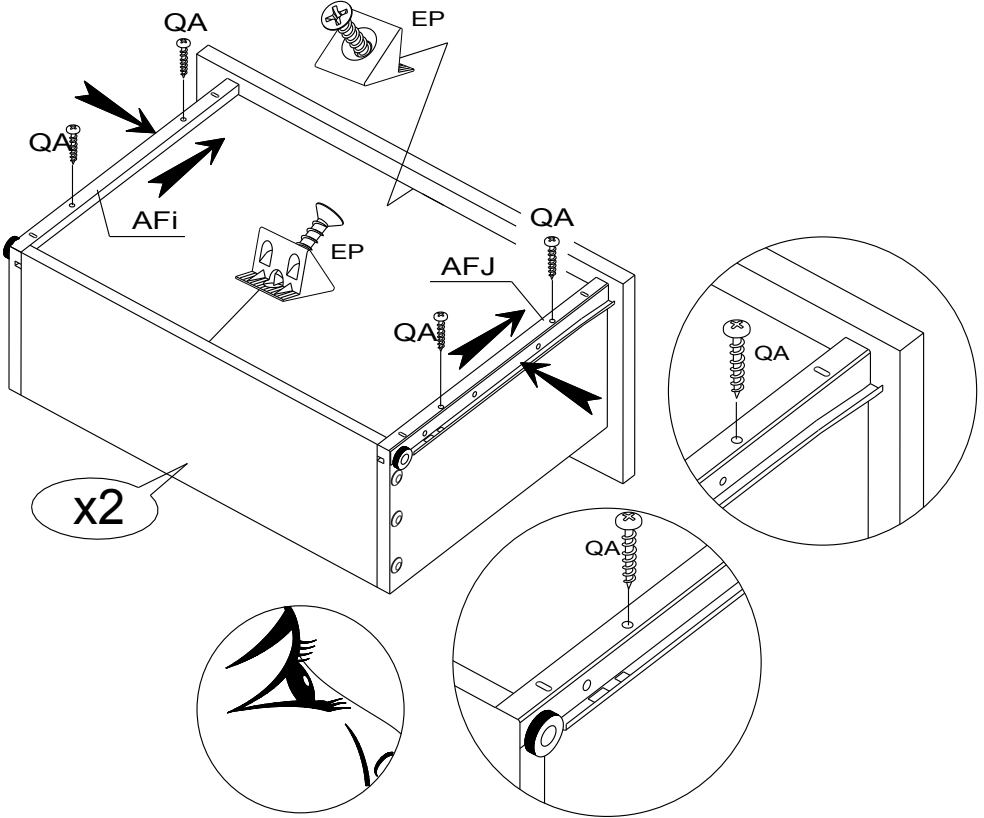

4



VG x 4

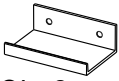

POI x 2

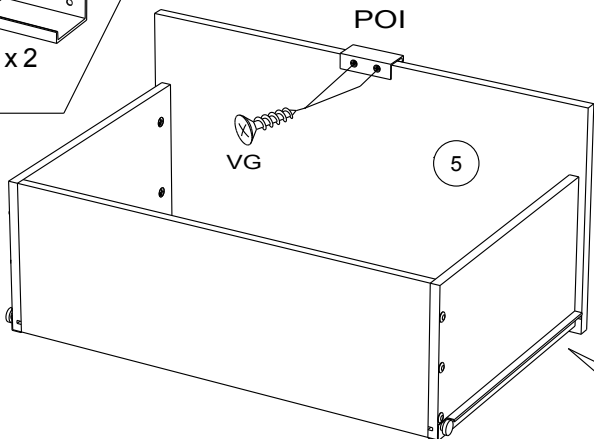

5

ADM x 4

BXC x 4

XN x 4

AHX x 2

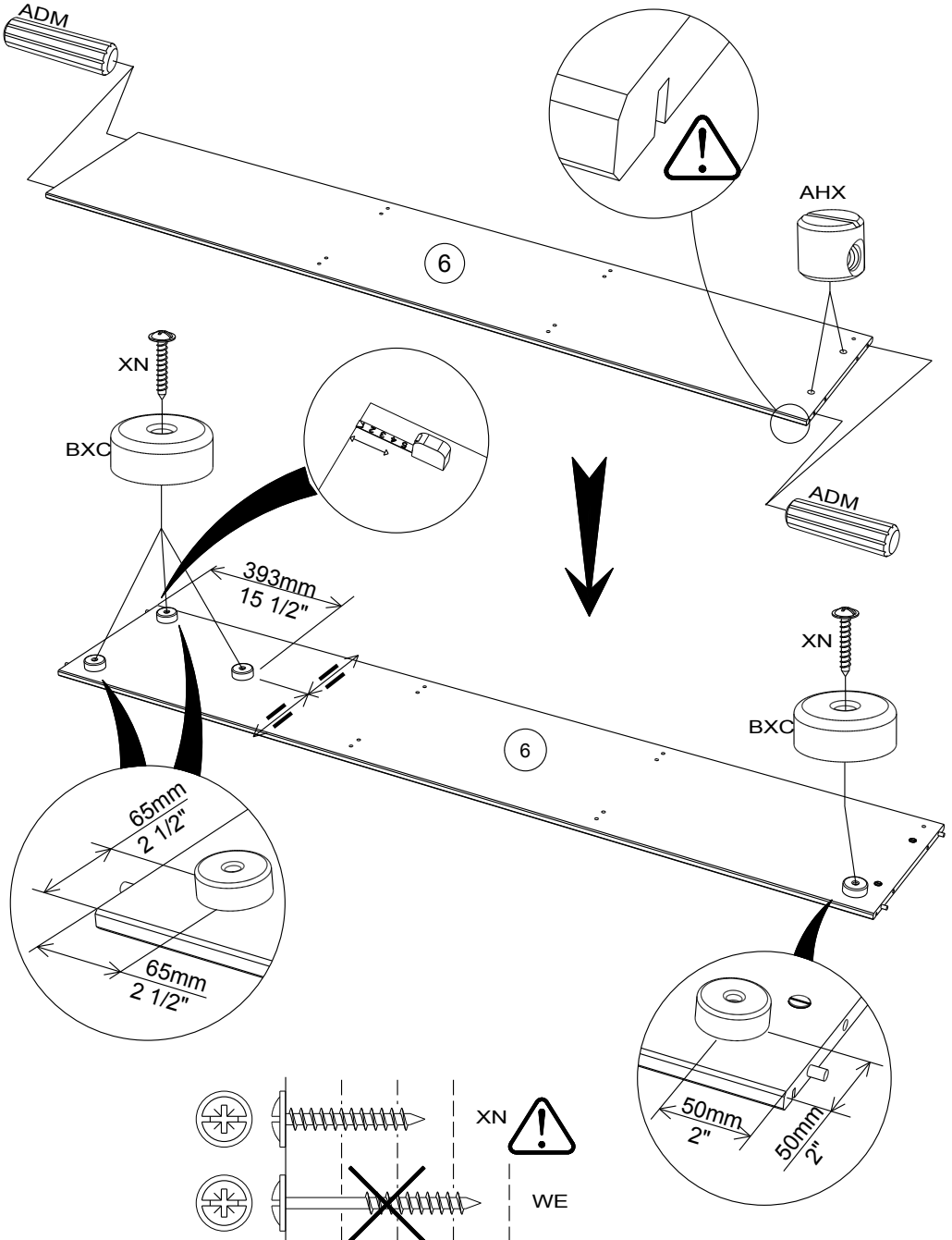

6

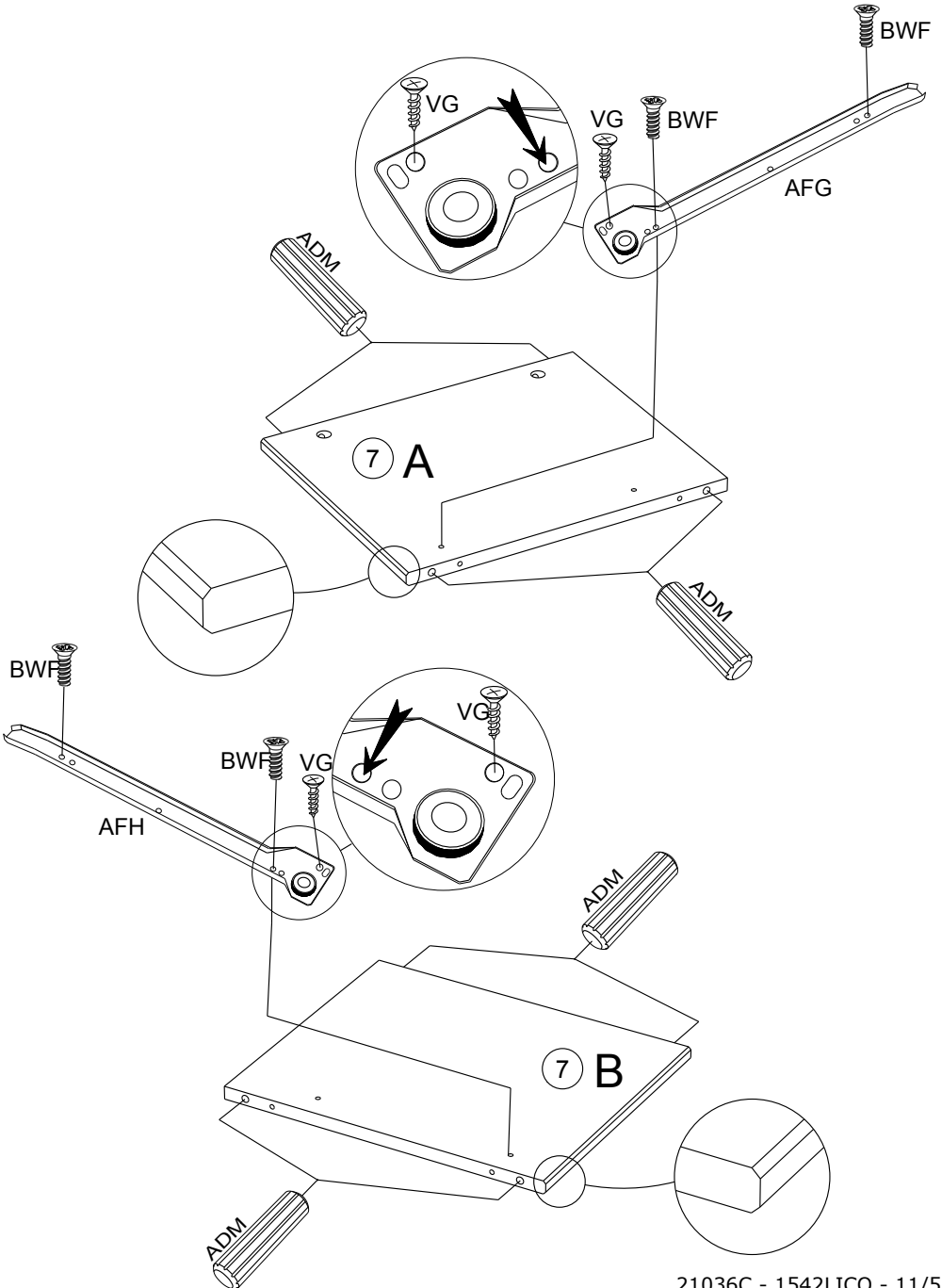
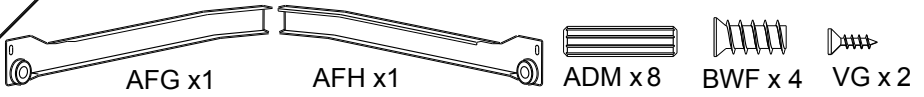

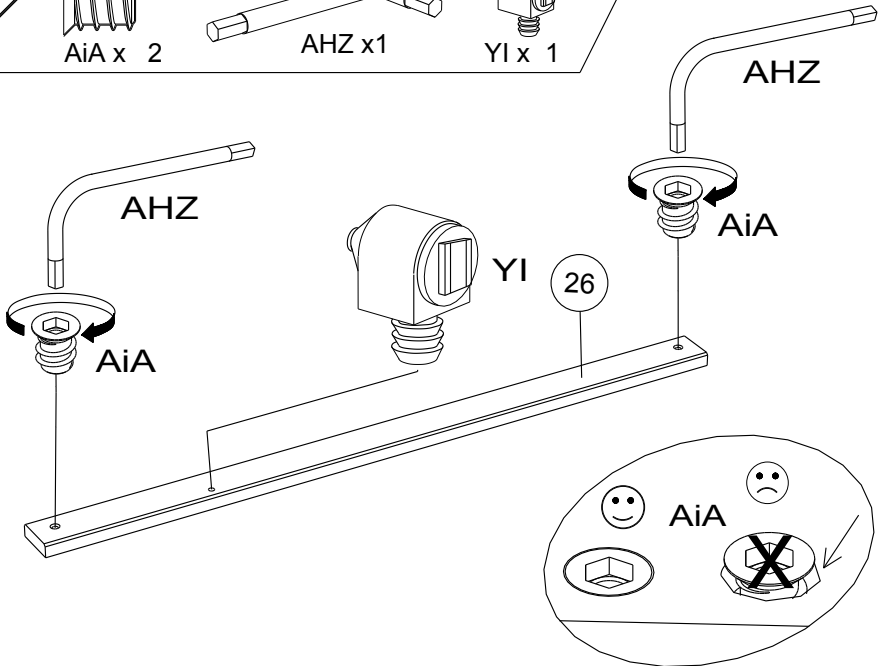
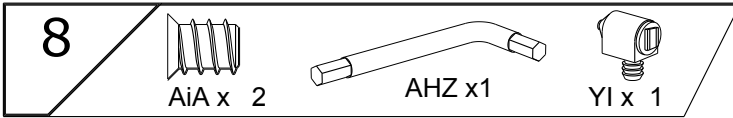
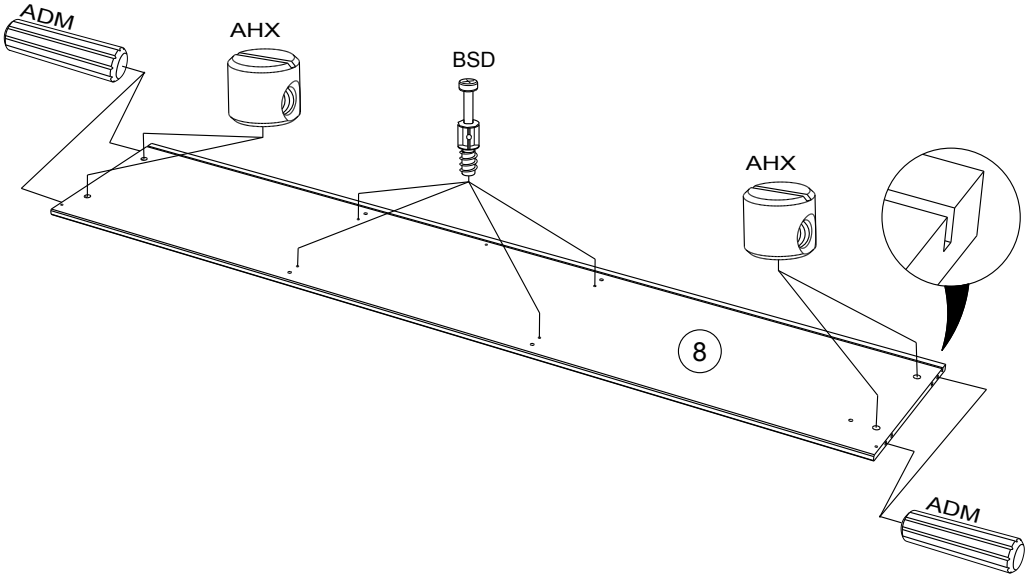
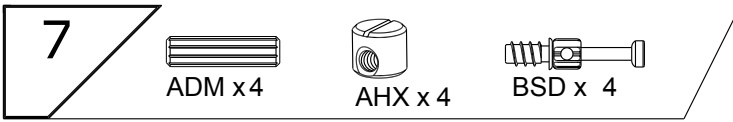

9



ADM x4



AHX x4

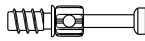

BSD x 2



AiA x 6



AHZ x1

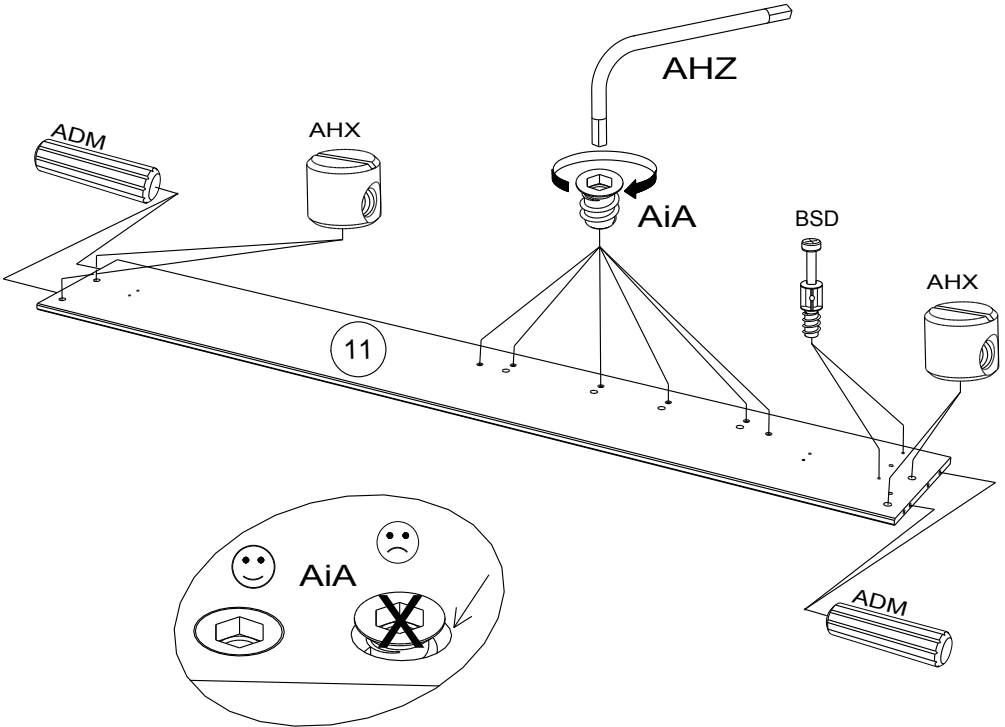

10

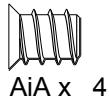

AiA x 4



AHZ x1



BGZ x 6



HV x1

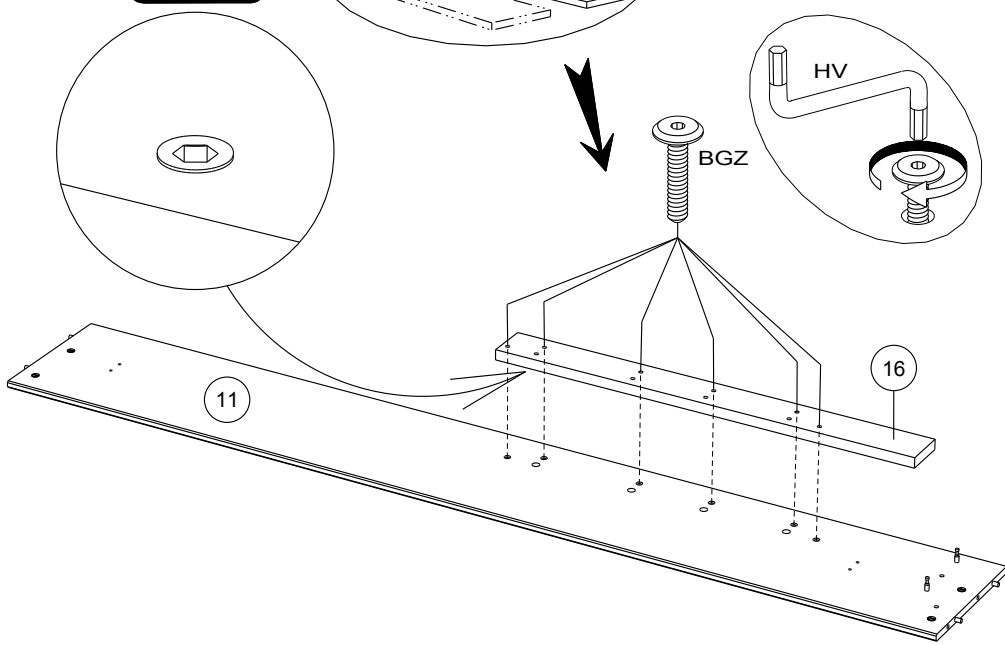
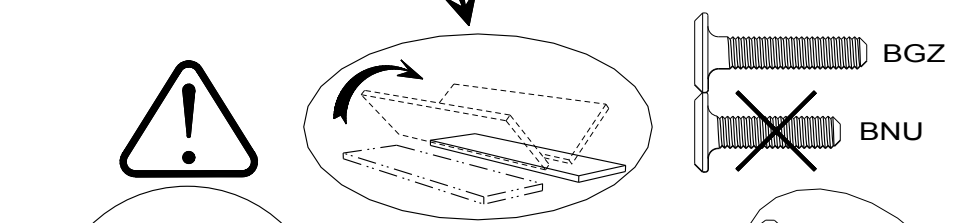
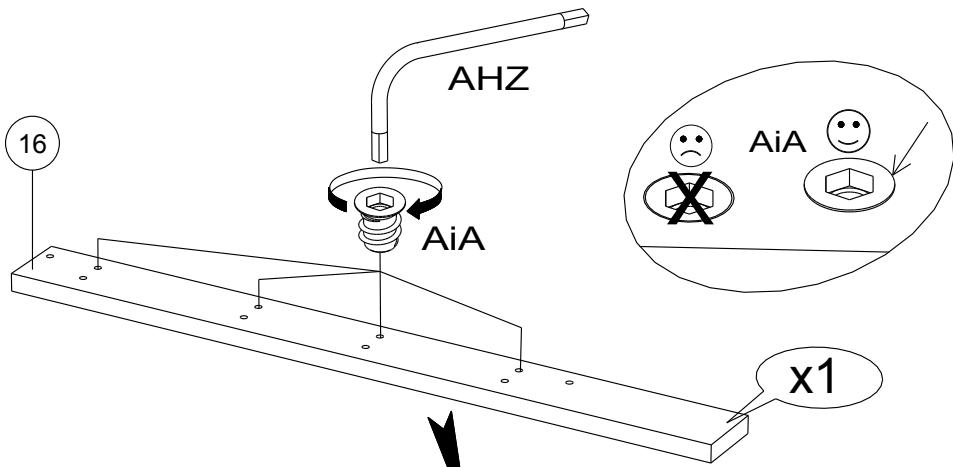

11



ADM x 4



AHX x 4



BSD x 2



AiA x 6



AHZ x 1

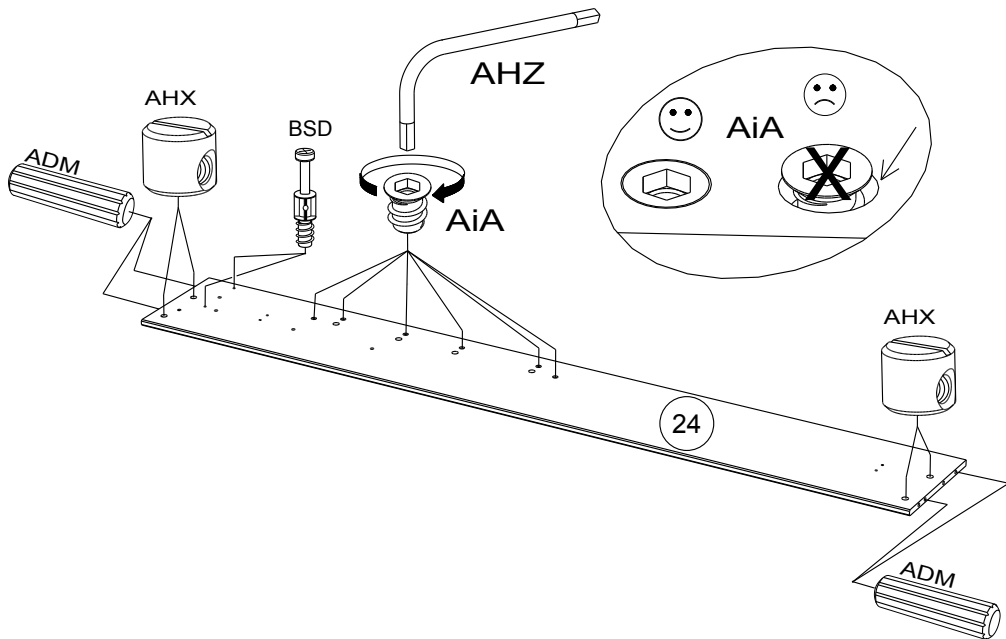

12



ADM x 2



AHX x 2



BSD x 2

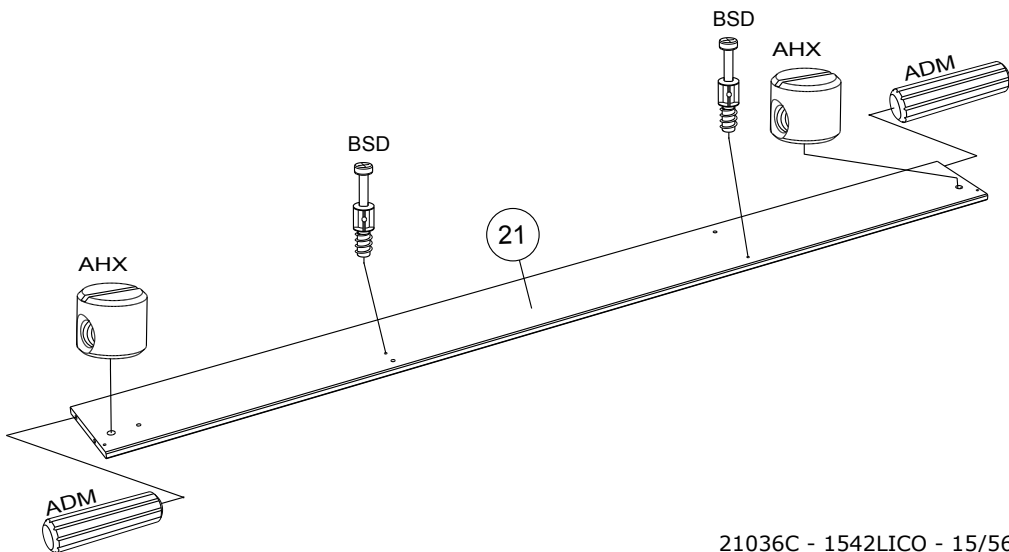

13

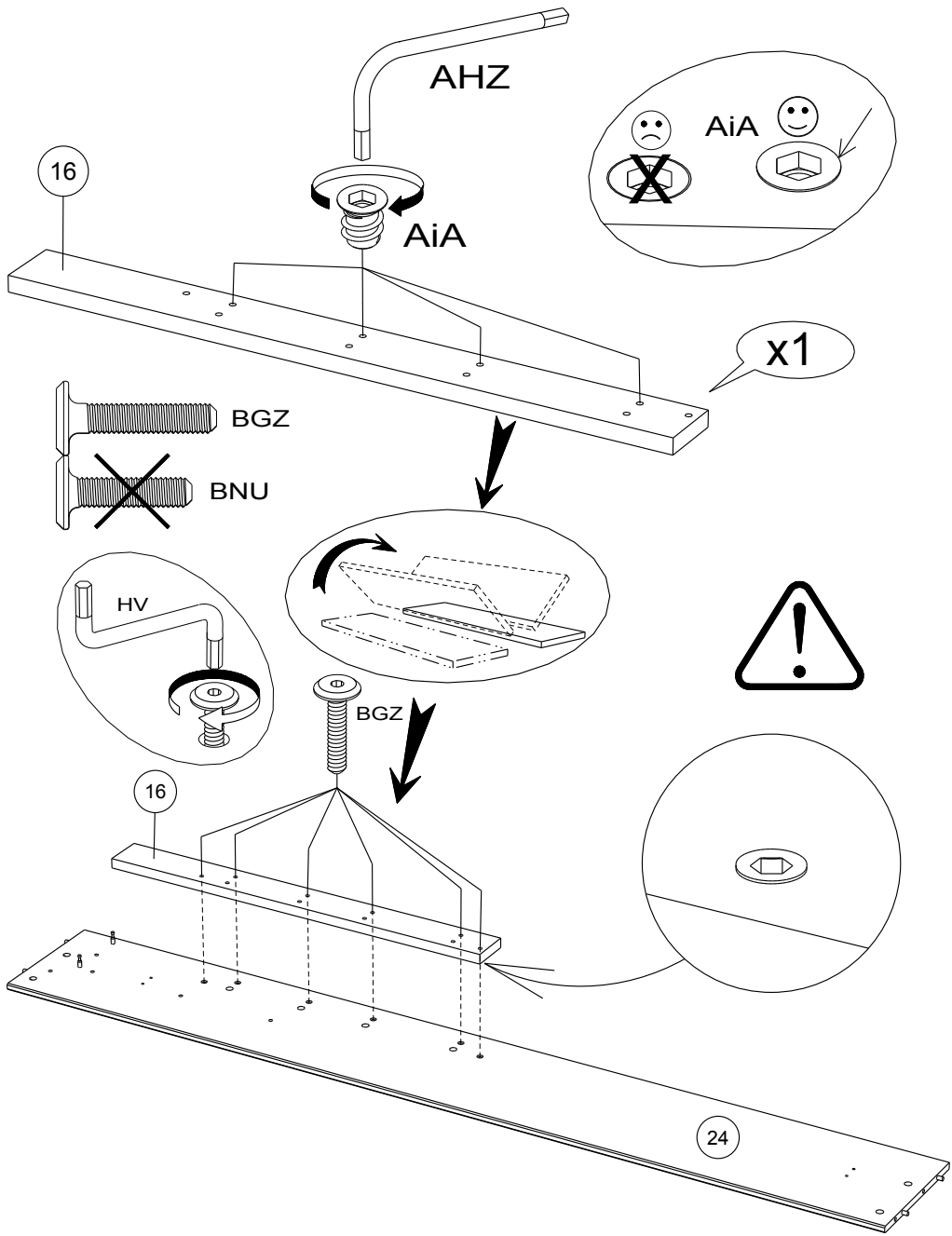
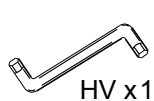

14



EO x1



BWU x2

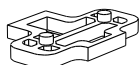

ANN x 2



CKL x 2

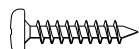

AGN x 4

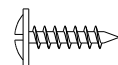

AMO x 4

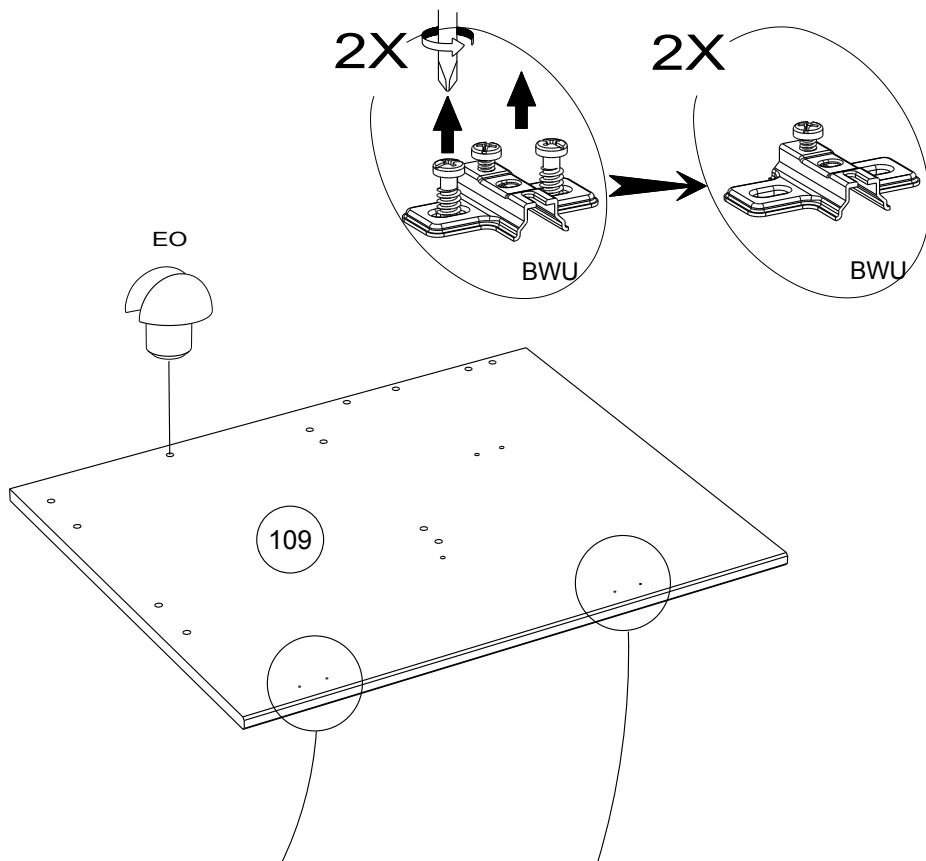

1°

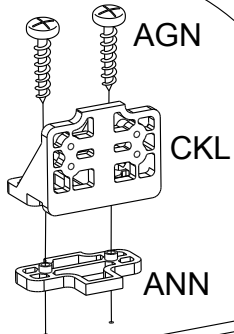

2°

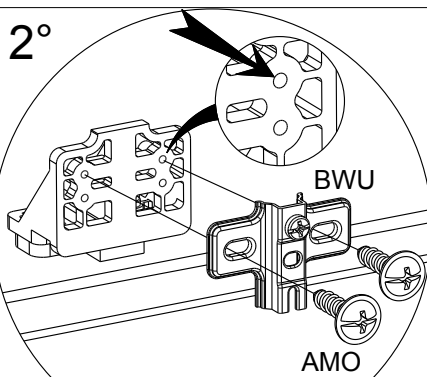

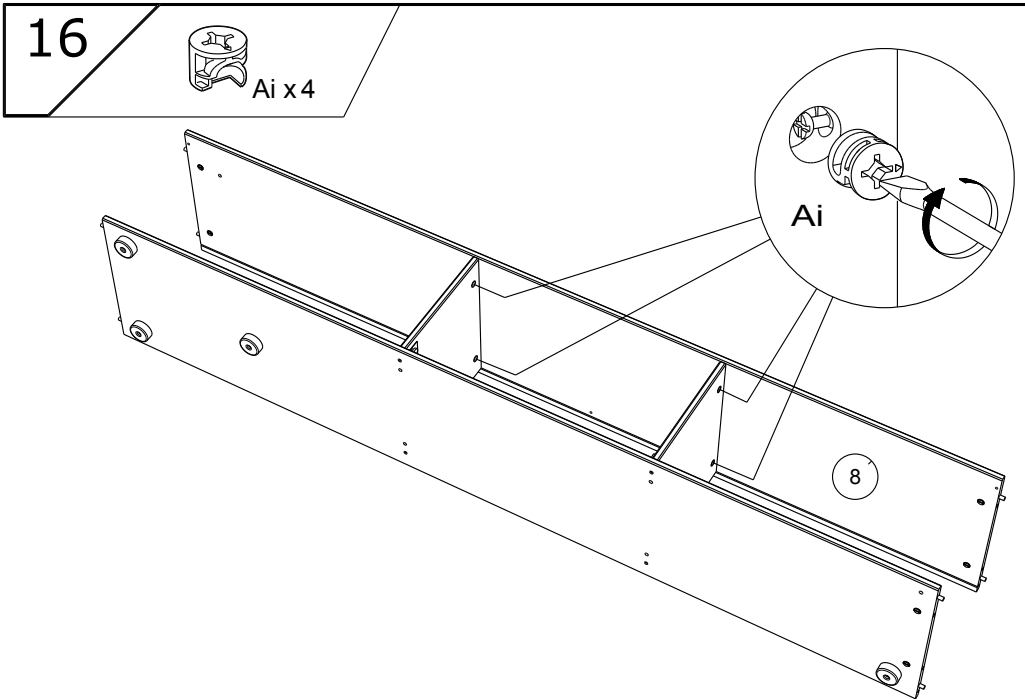
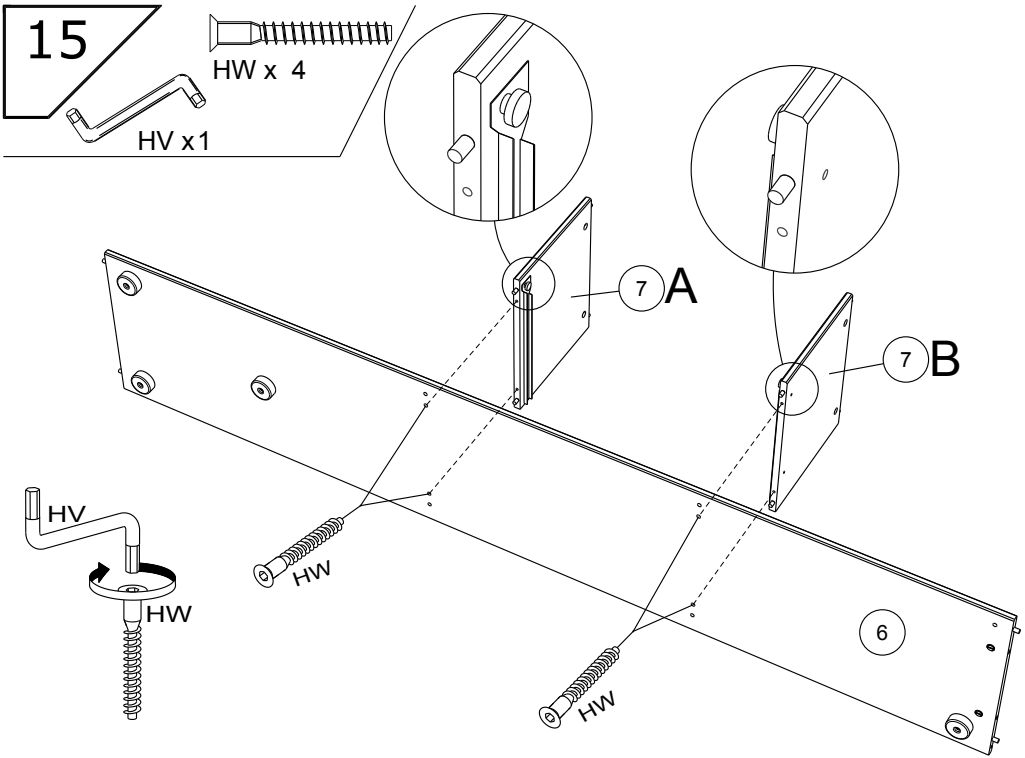

17

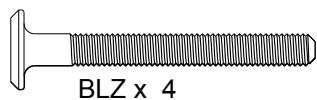

BLZ x 4



HV x 1

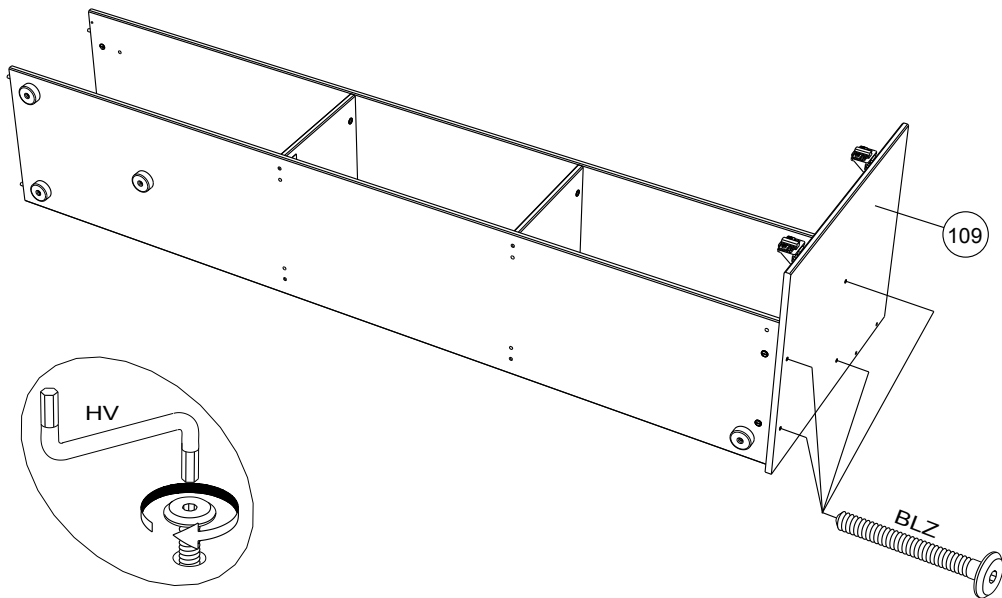

18



BXC x 4

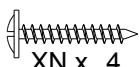

XN x 4

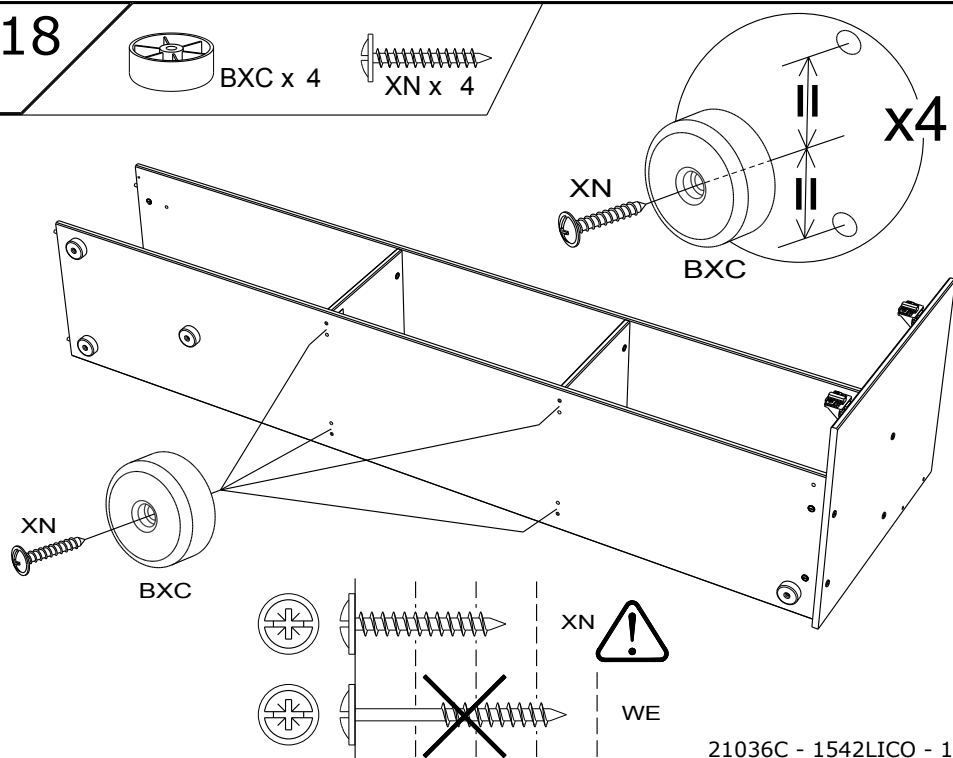

19a

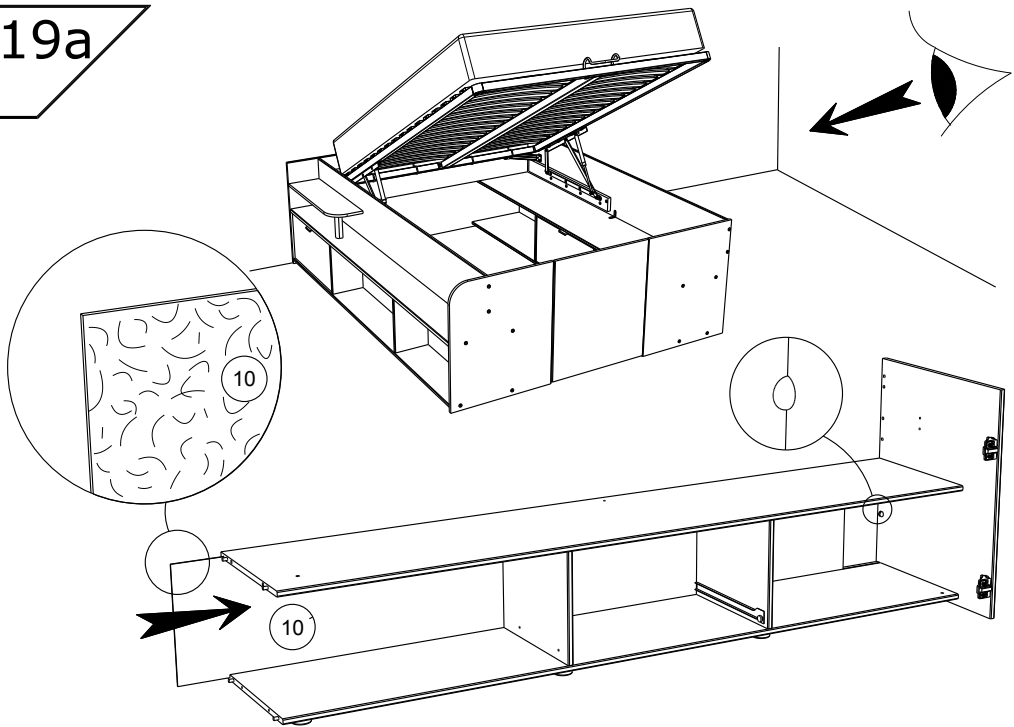

19b

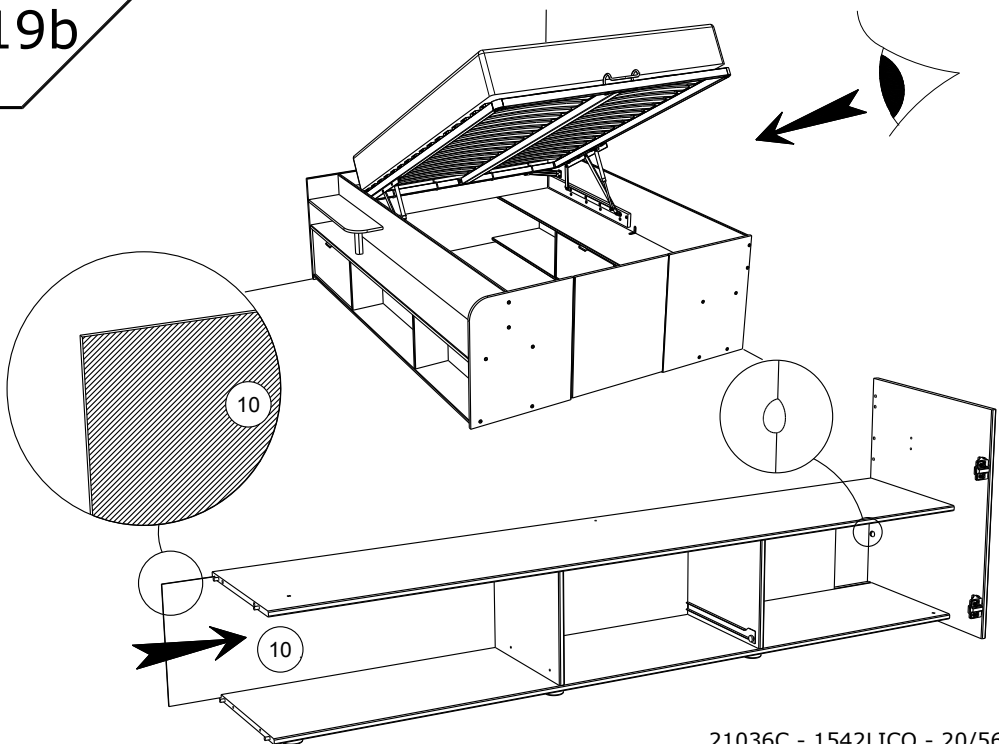

20

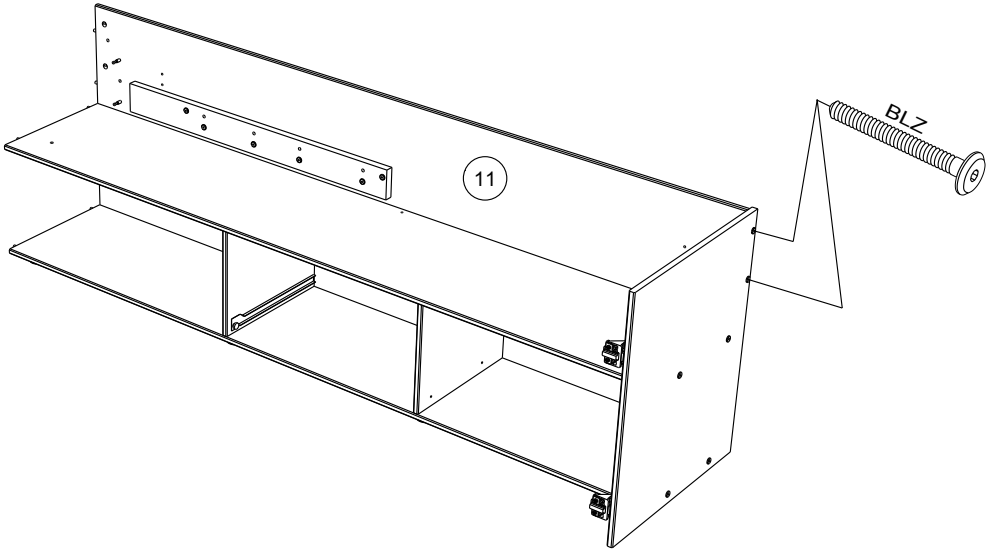
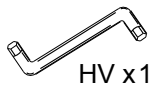
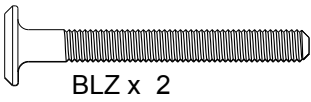

21

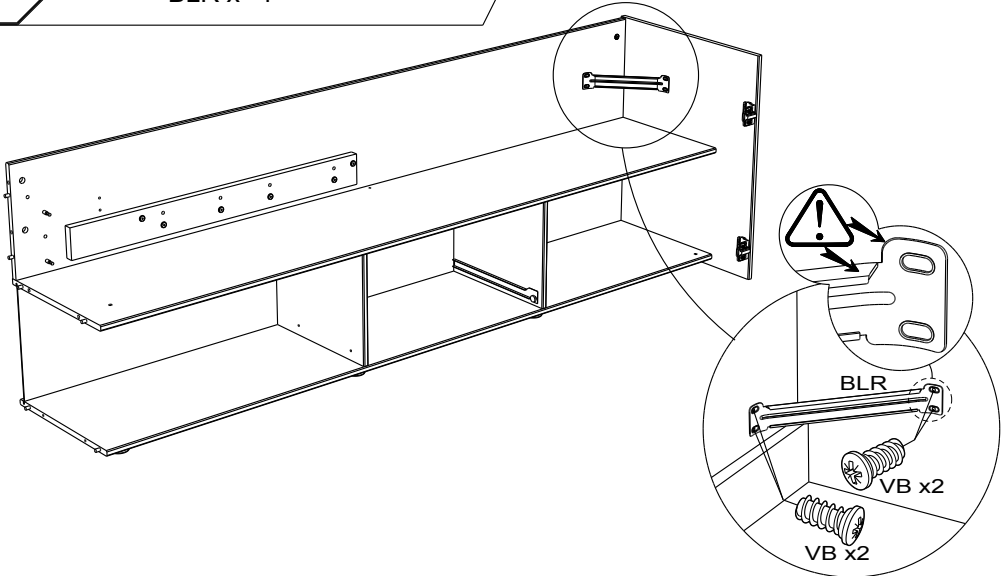

22

ADM x 4

LN x 3

ANK x 6

VG x 6

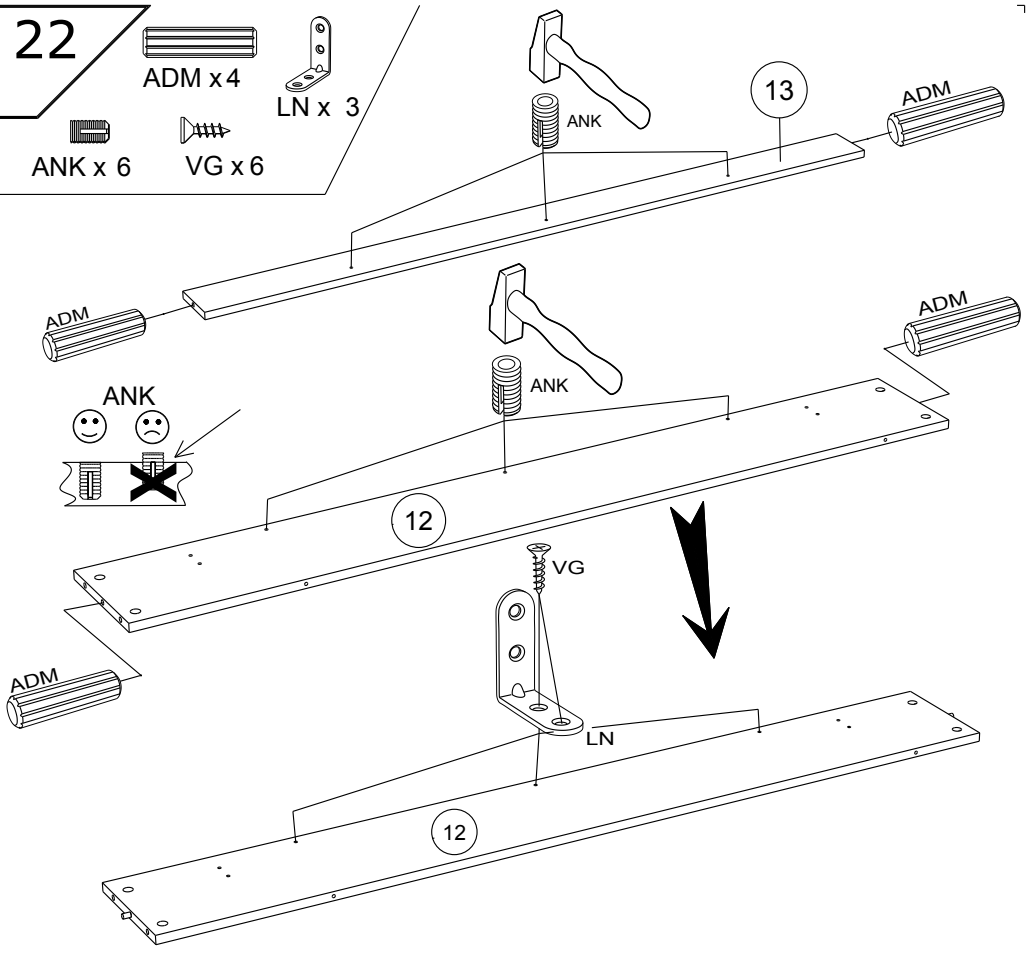

23

VG x 6

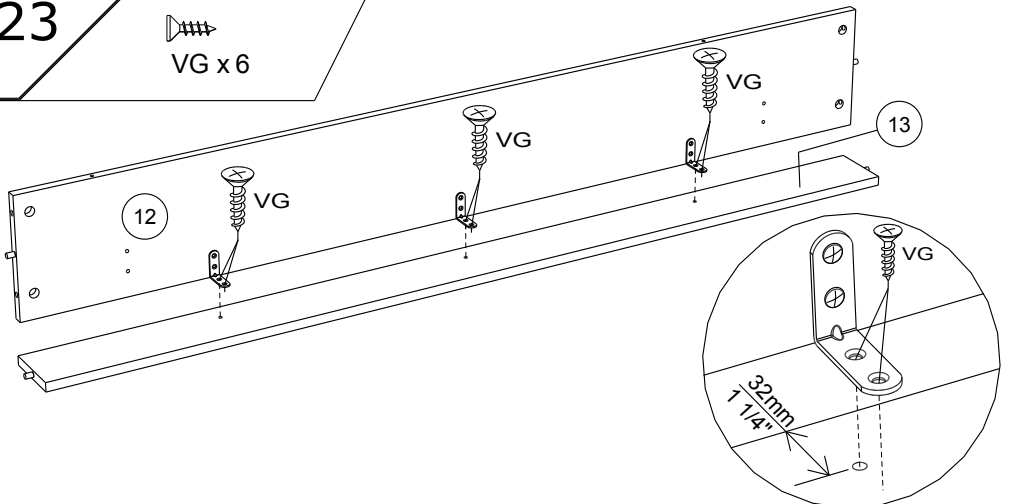

24



ADM x 4



BXC x 6



XN x 6



AHX x 2

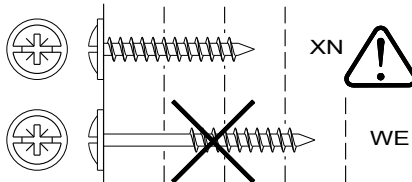
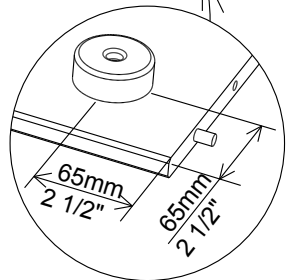
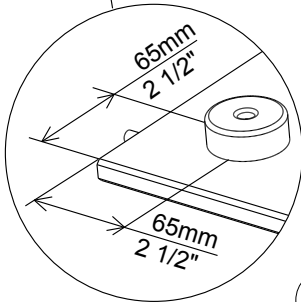
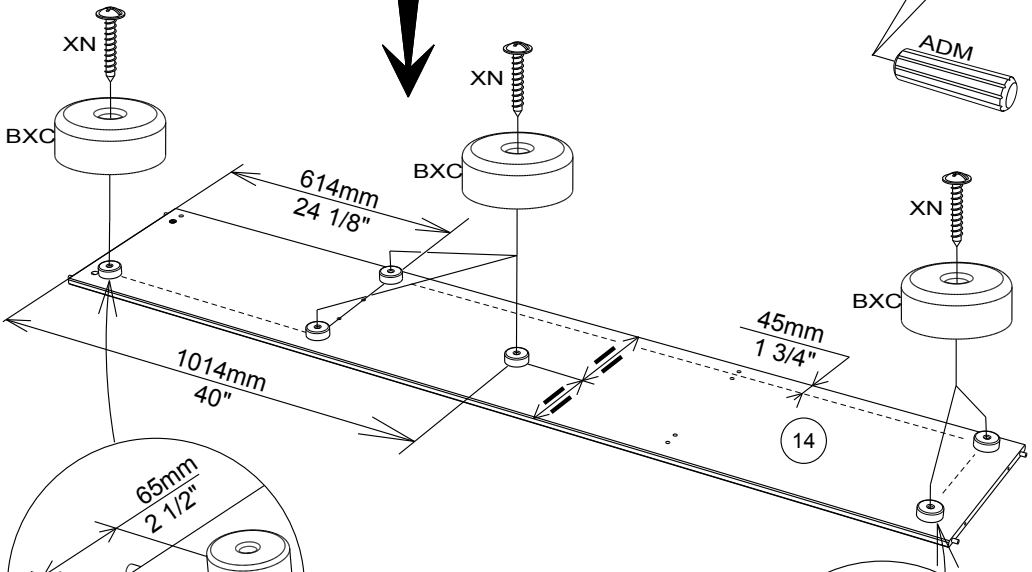
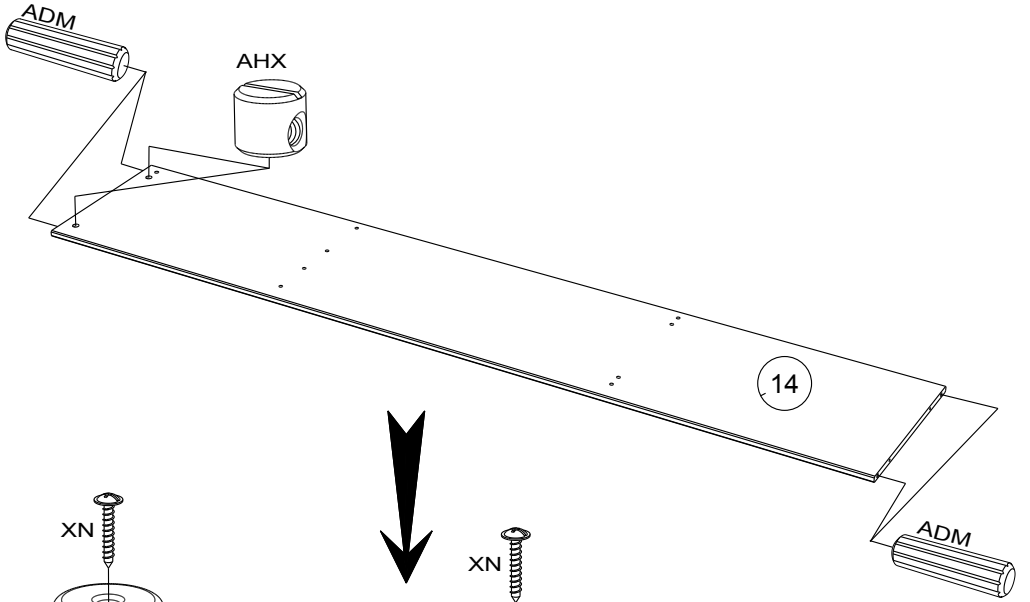

25

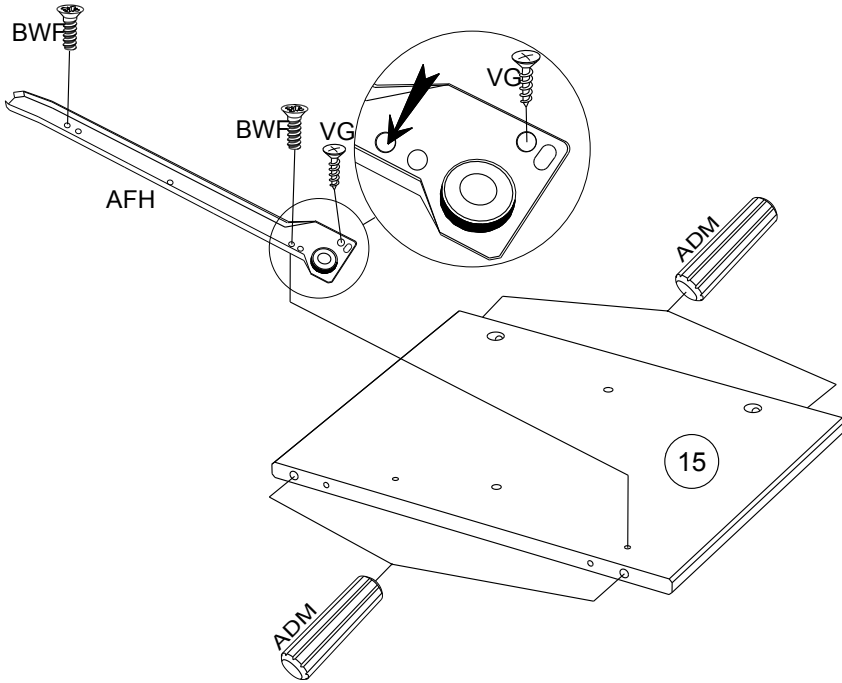
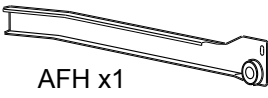

26

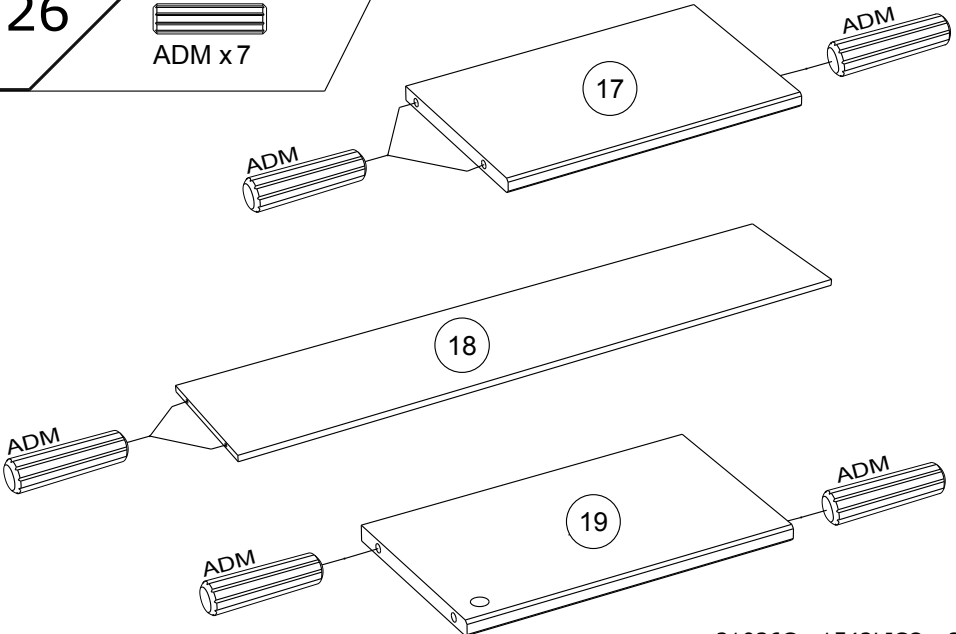

27

ANK x 2

AMO x 2

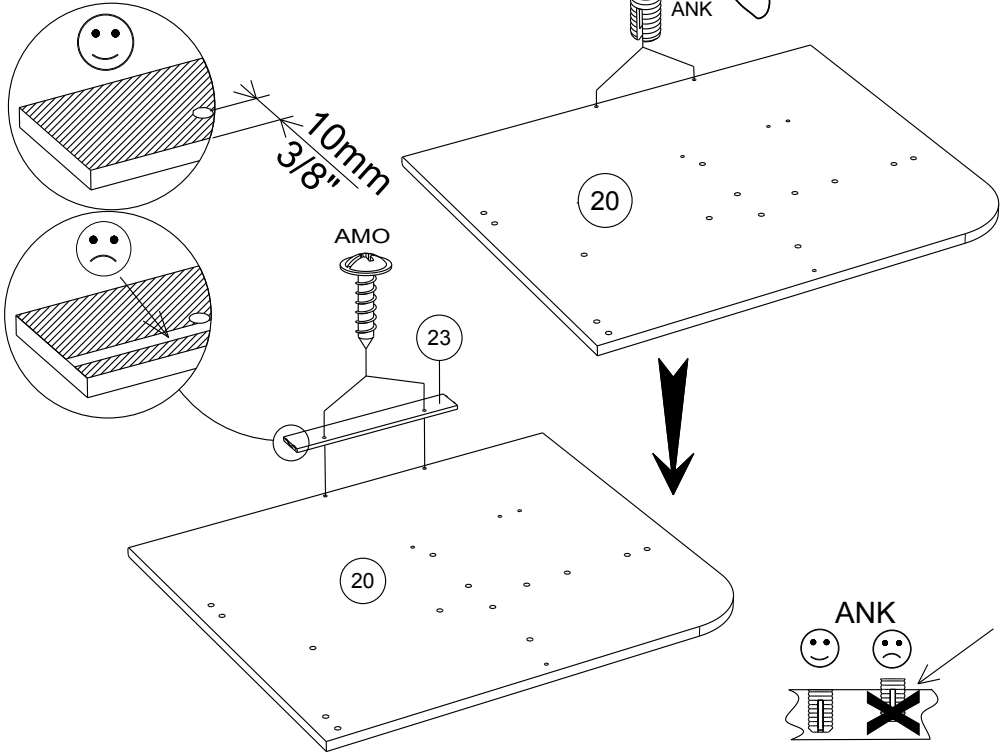

28

ADM x 2

AHX x 2

BSD x 1

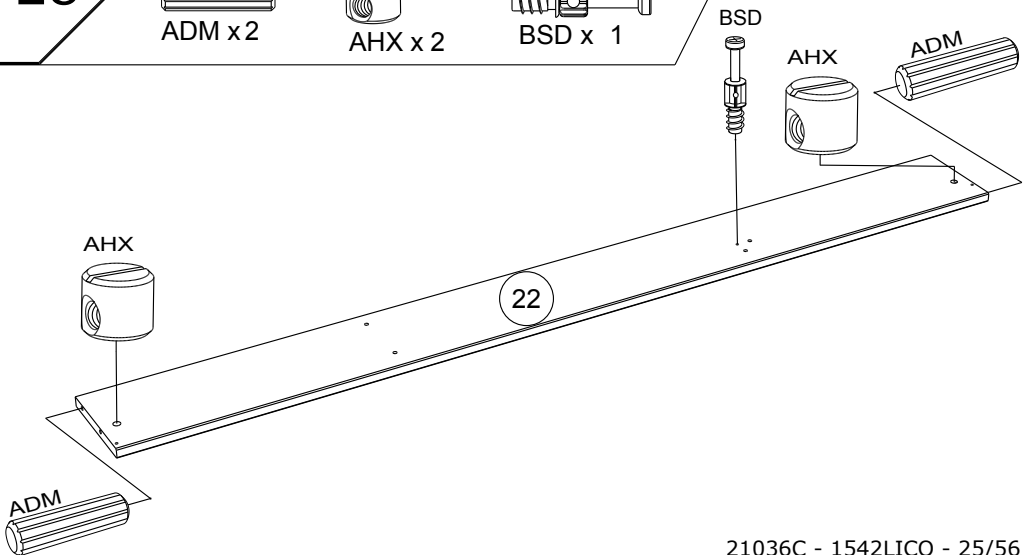

29

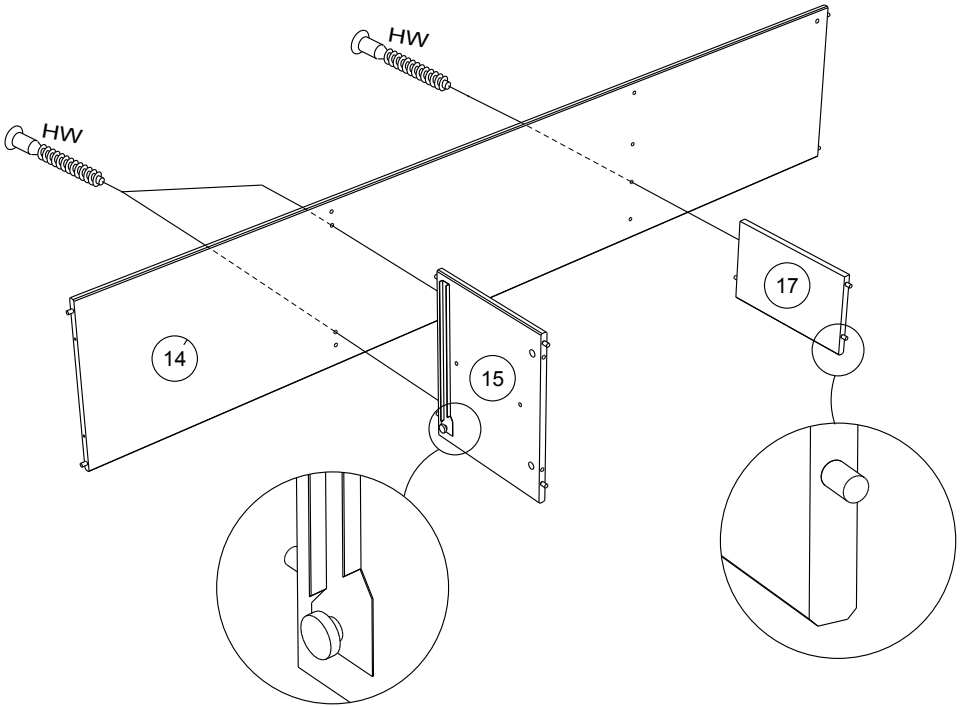
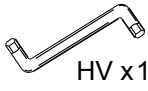
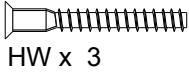

30

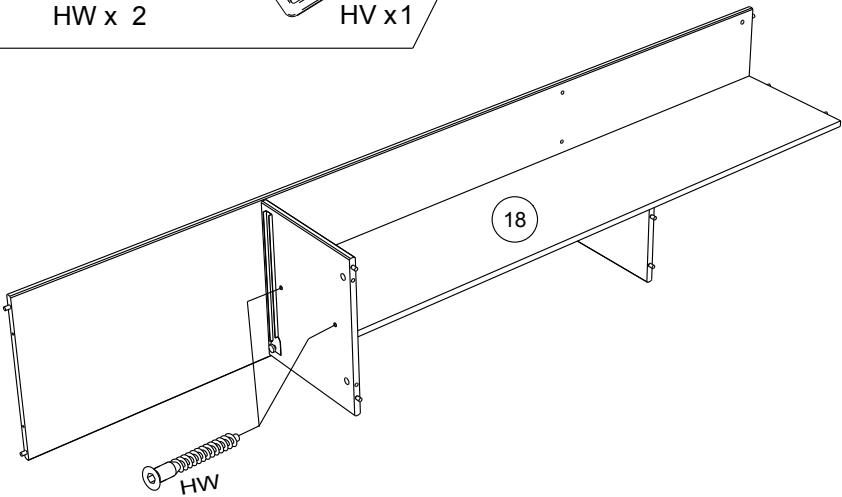
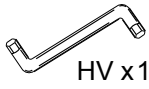
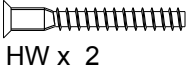

31

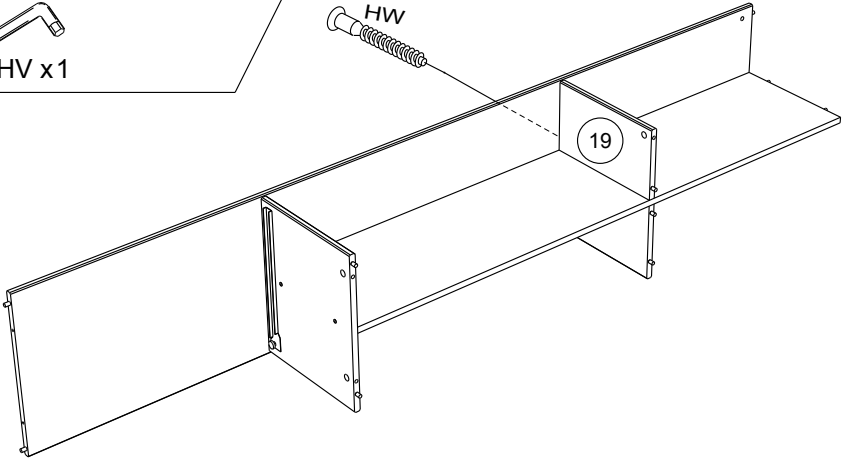
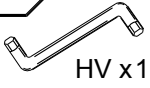
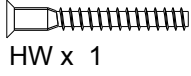

32

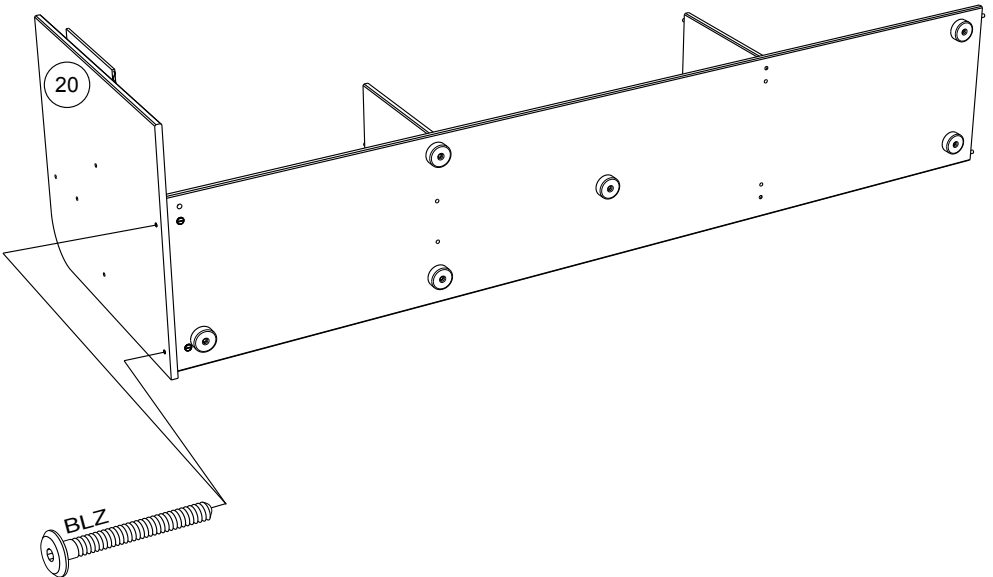
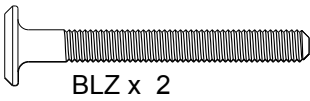

33



BXC x 2



XN x 2

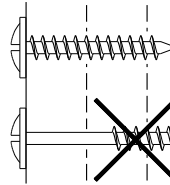
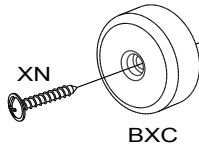
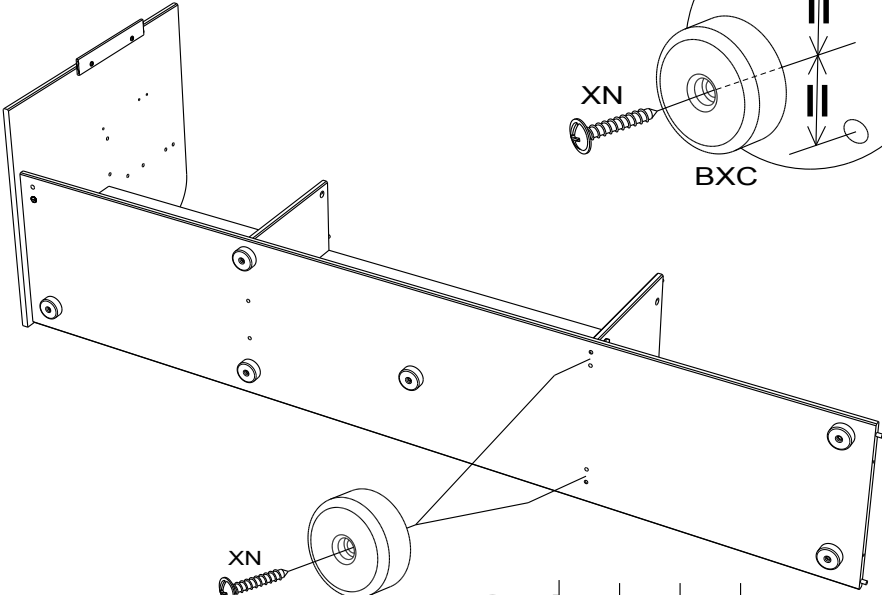
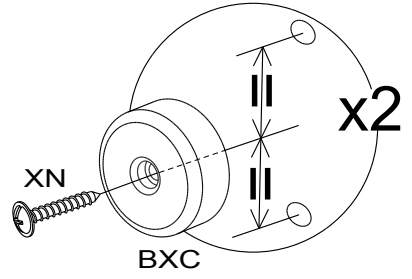

XN



WE

34

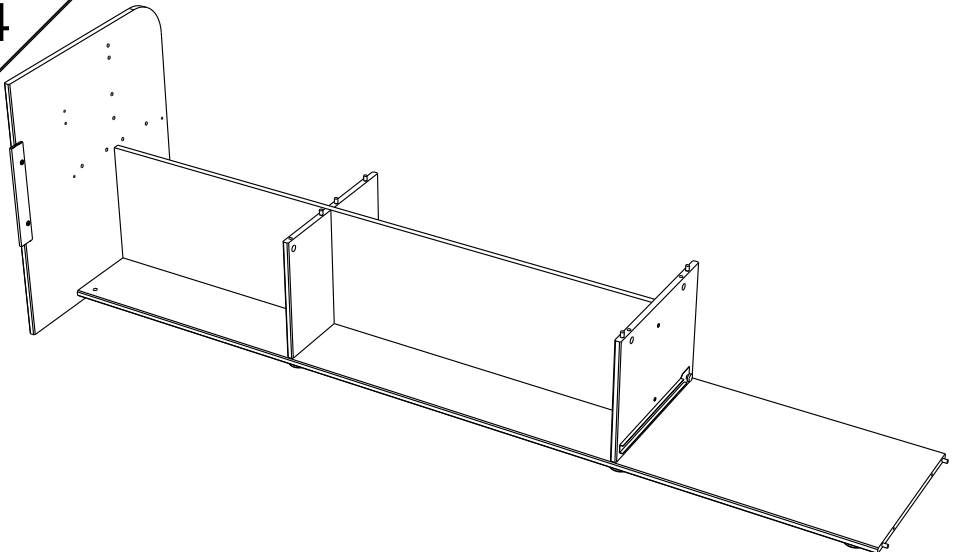

35

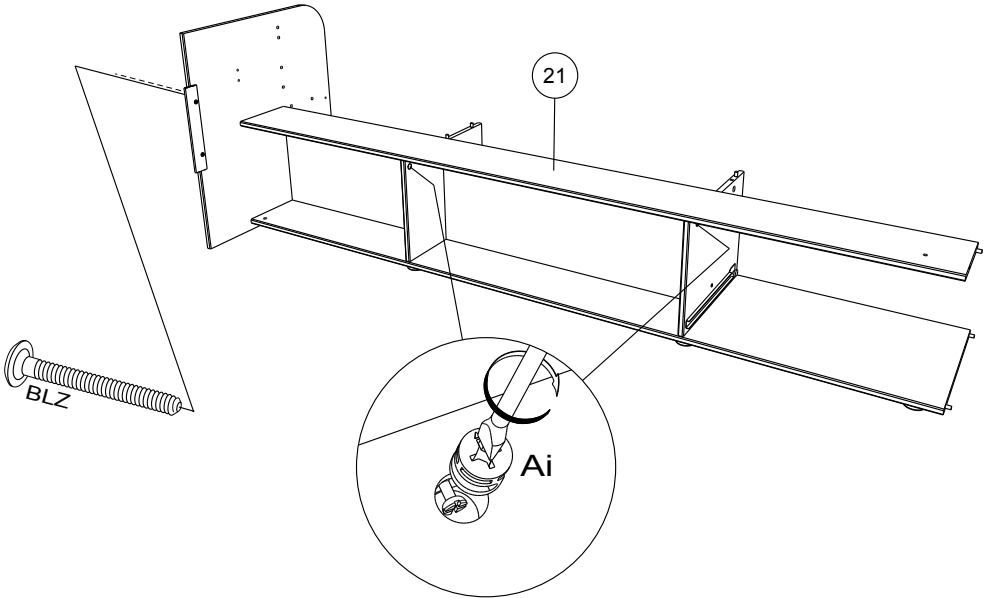
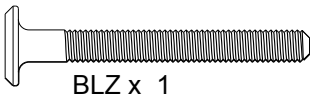

36

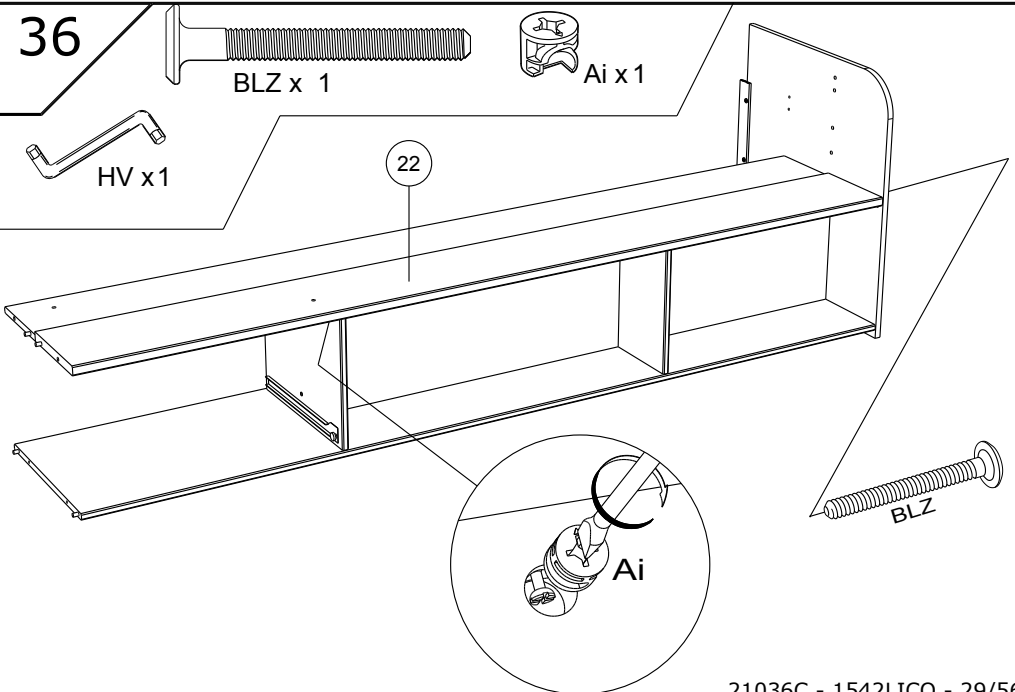
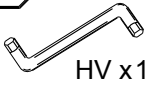
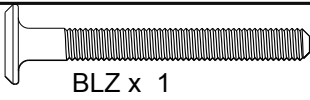

37

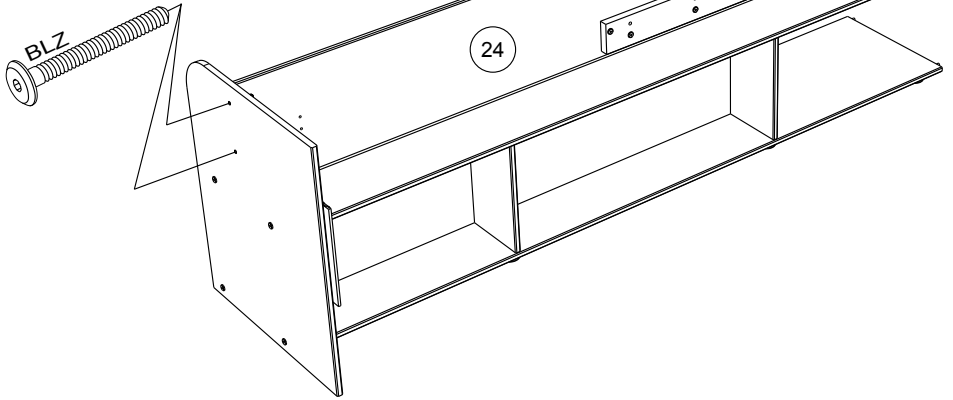
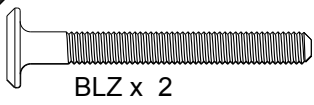

38

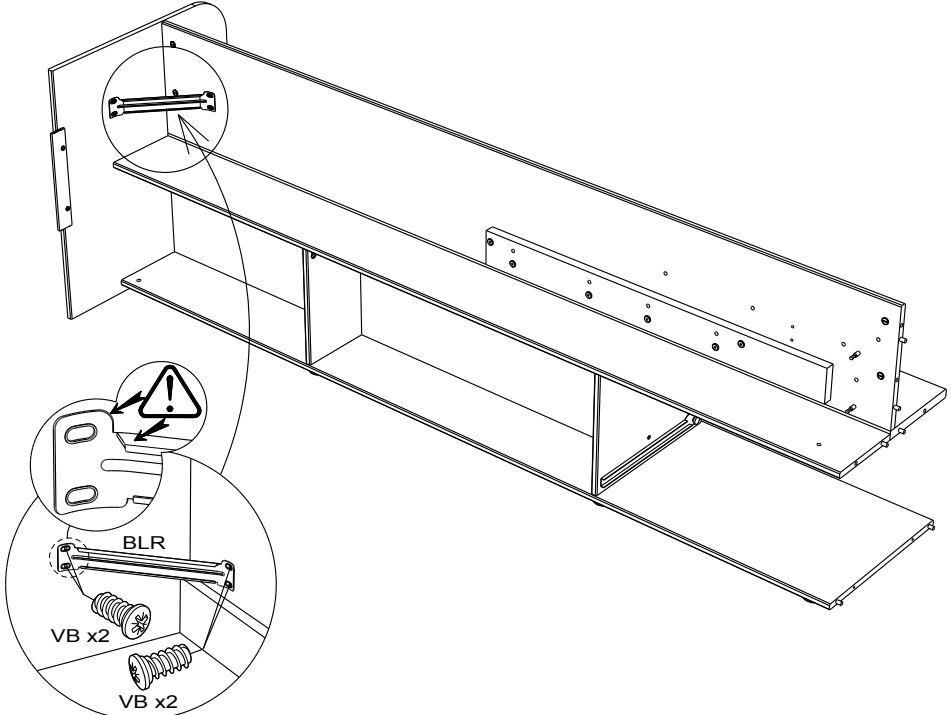

39

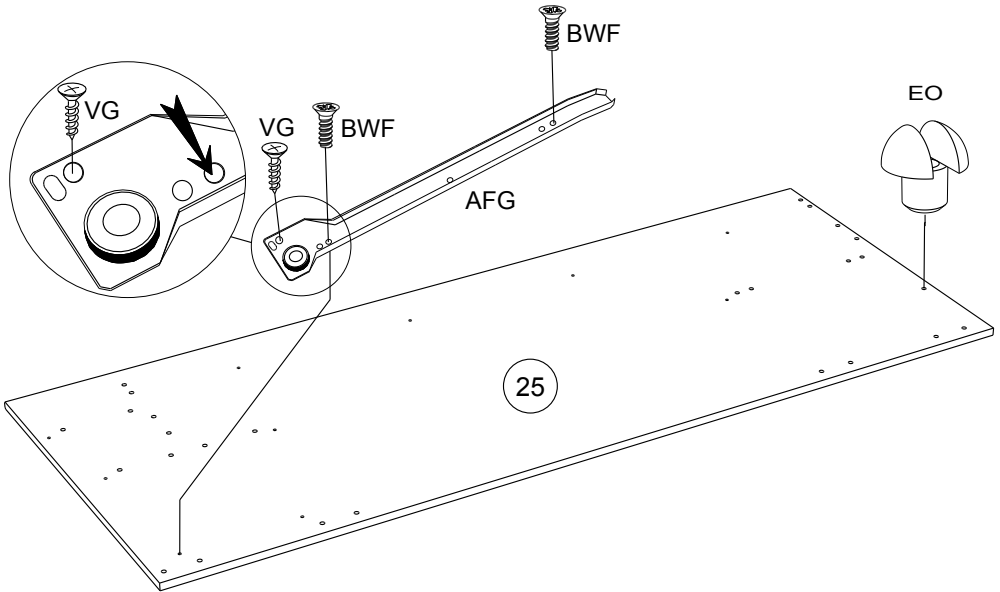

40



Ai x 2

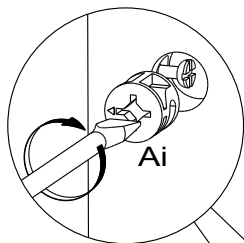

Ai

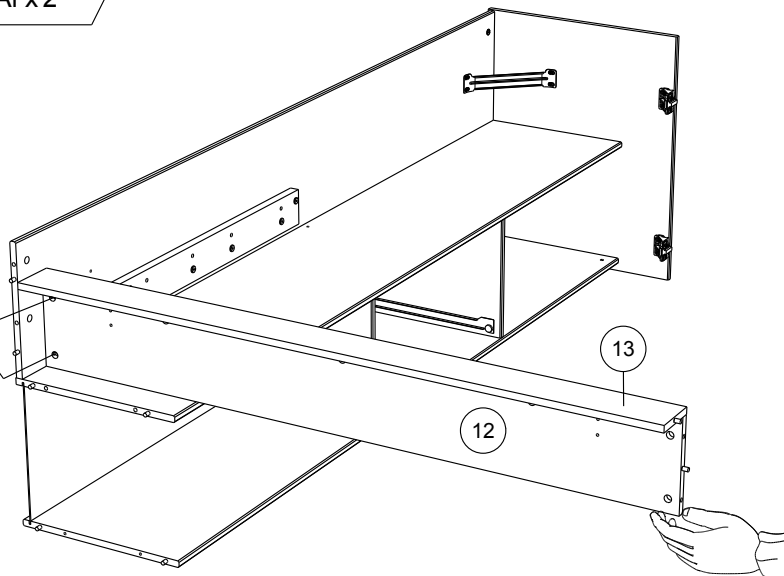

41

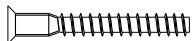

HW x 1



HV x 1

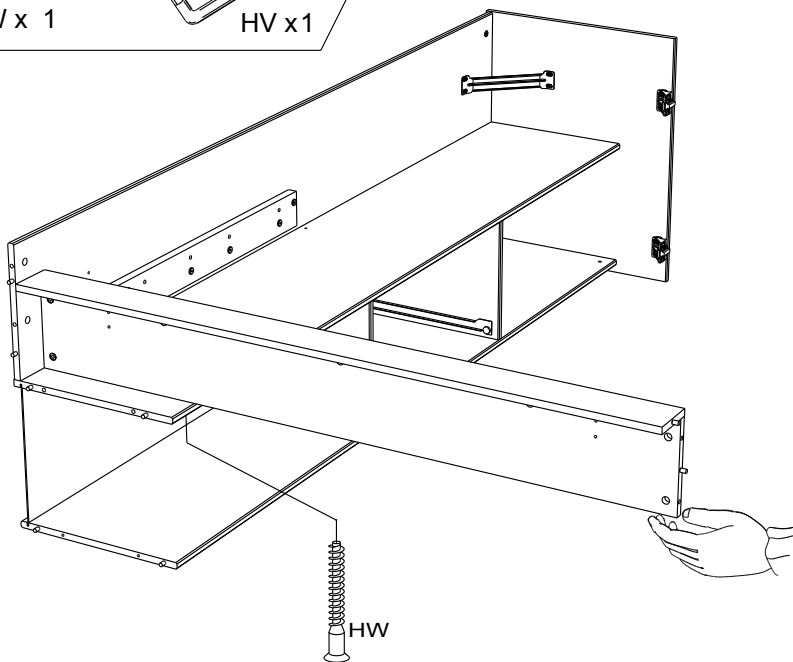

HW

42



Ai x2

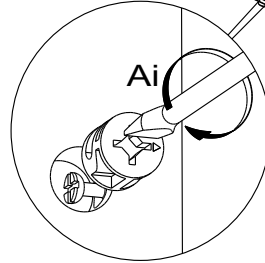
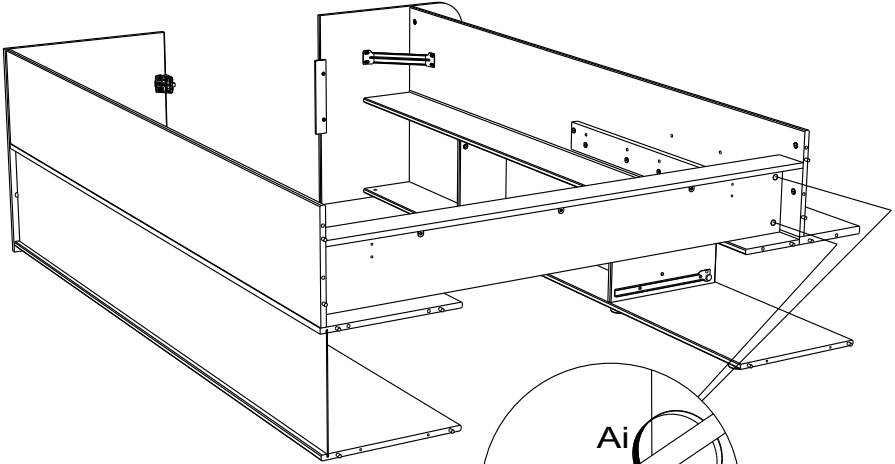

43

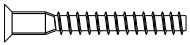

HW x 1



HV x1

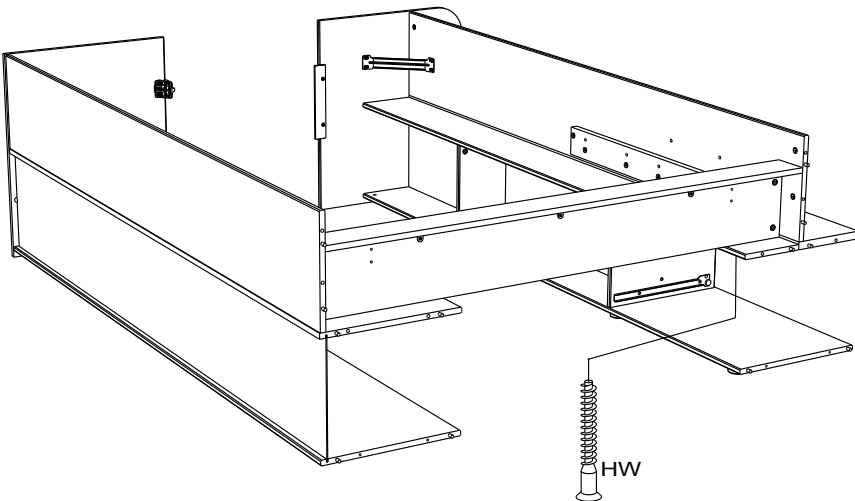

44

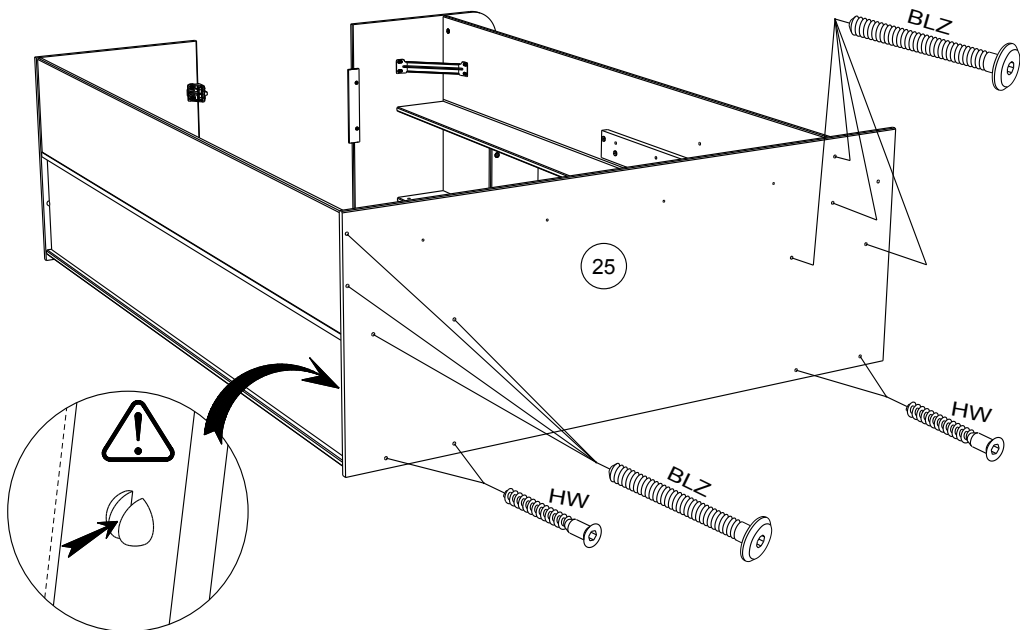
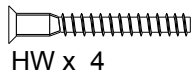
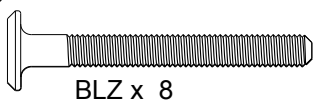

45

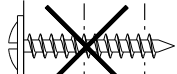
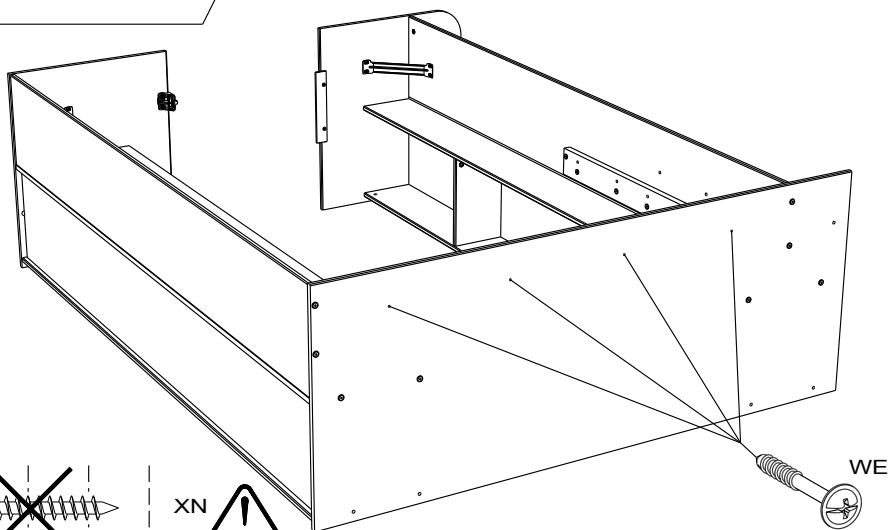
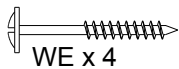

XN

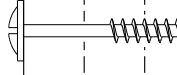

WE

46

BNU x 2

HV x 1

BNU

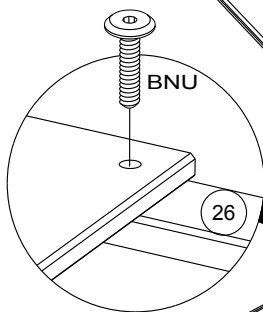
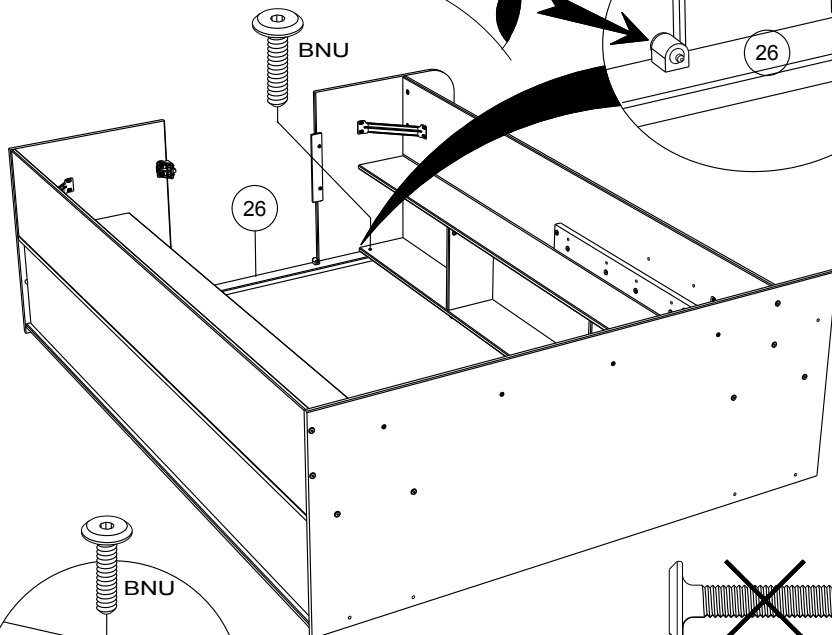

~~BGZ~~
BNU

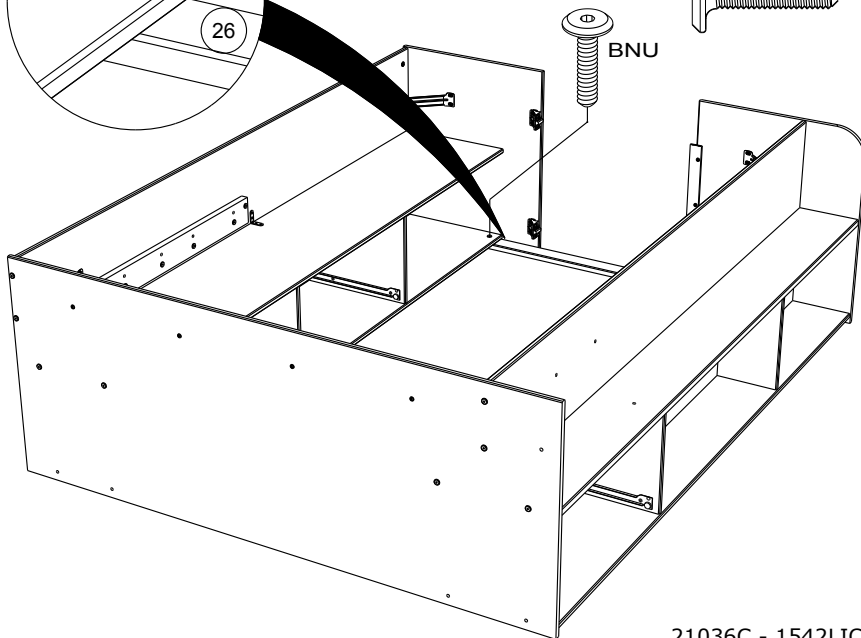

47

QA x 2

BLR x 2

VB x 8

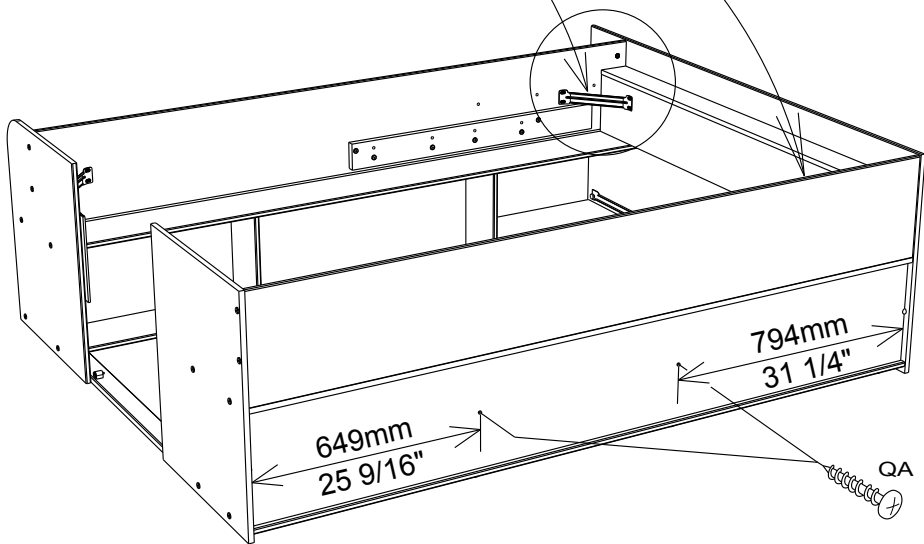
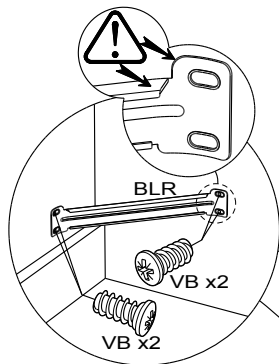

48



EP x4



ANK x 1

ANK

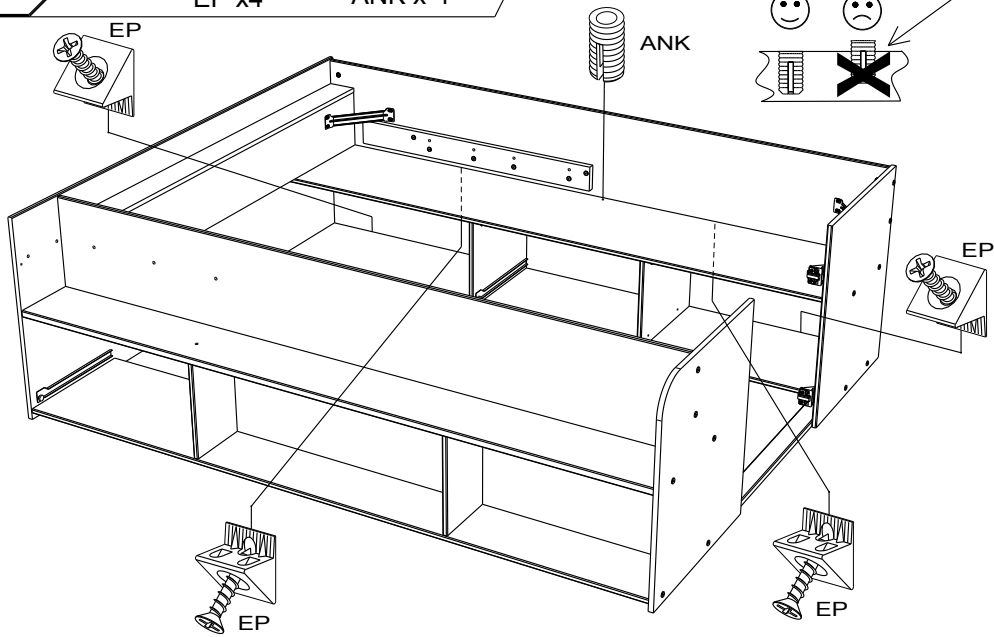
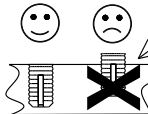

49



ADM x 1



AHX x 4

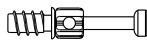

BSD x 1

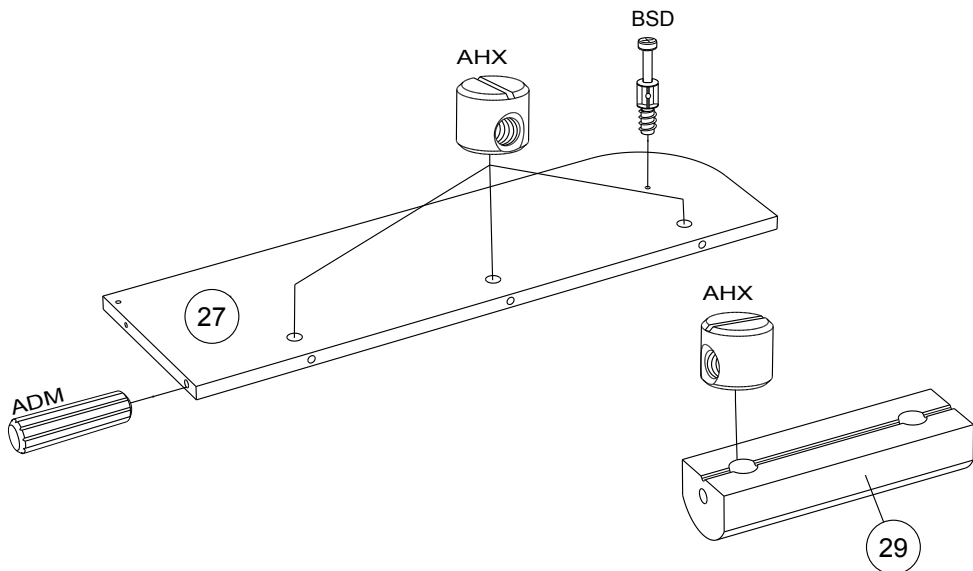

50



Ai x 1

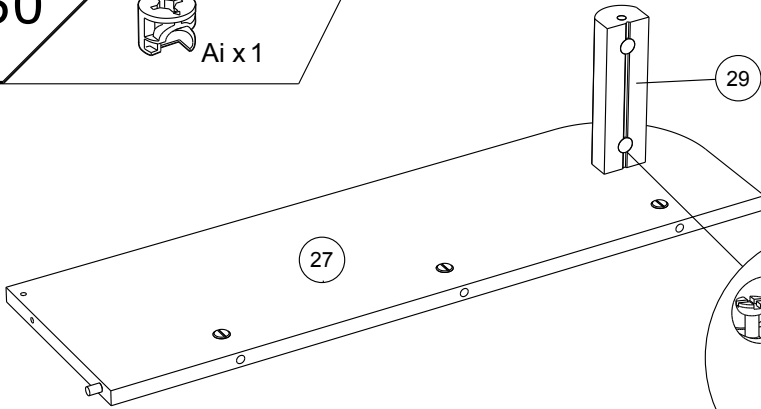

27

29

Ai

51

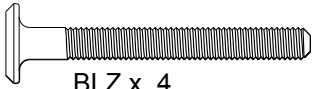

BLZ x 4



LN x 1

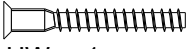

HW x 1



HV x 1



VG x 4

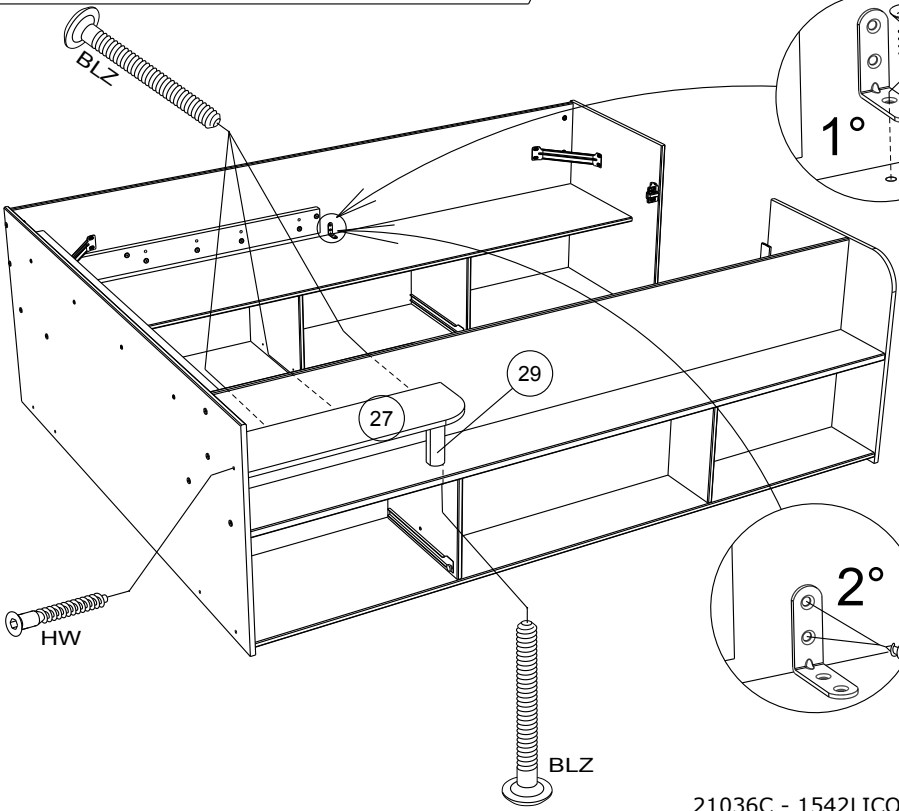

BLZ

VG

1°

27

29

HW

2°

VG

BLZ

52



BAG x 5



VB x 5

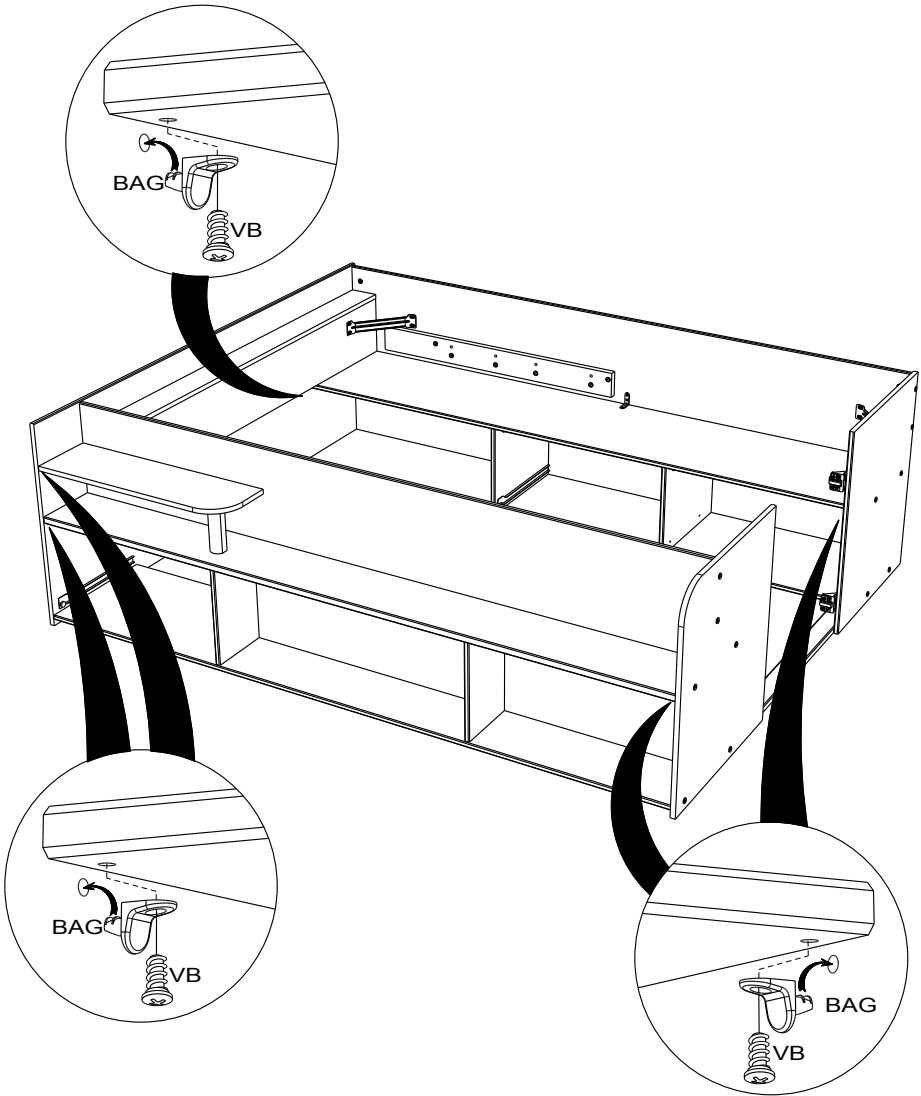

53



BAG x 2



VB x 2

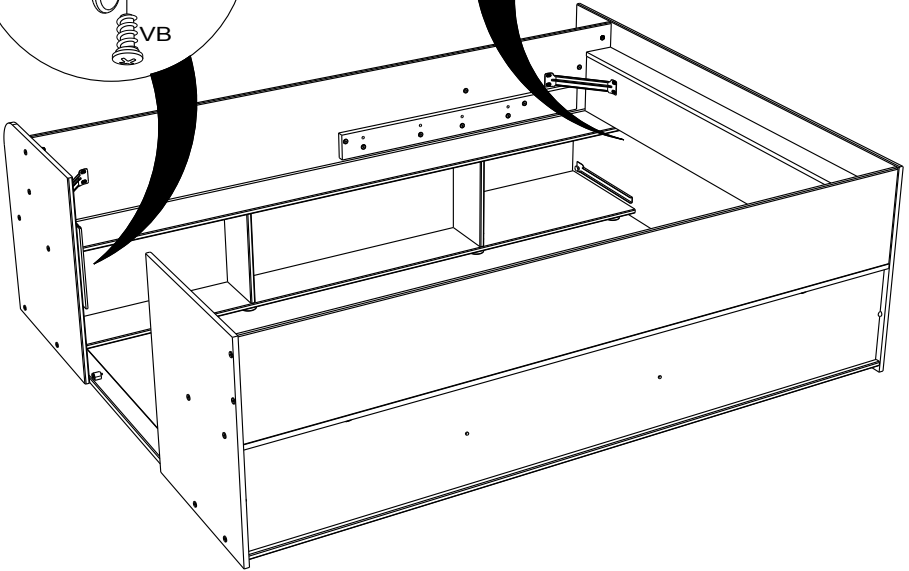
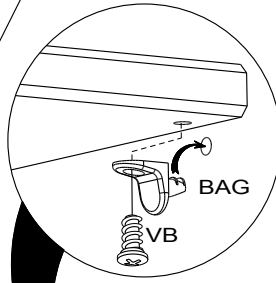
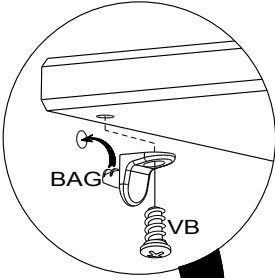

54

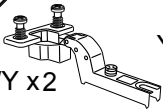

BWY x 2



YJ x 1

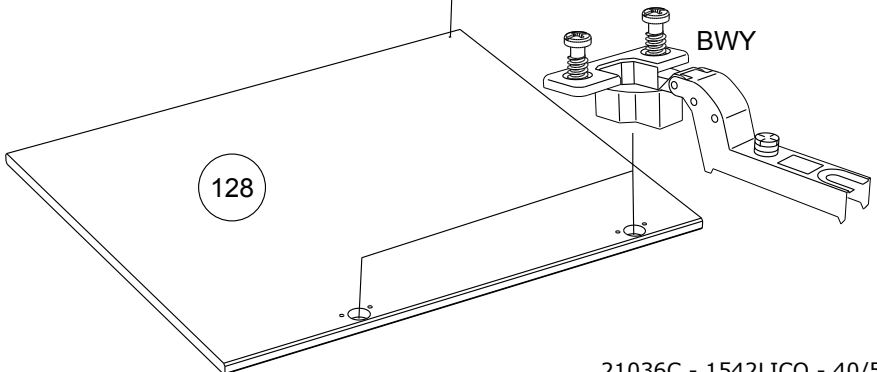
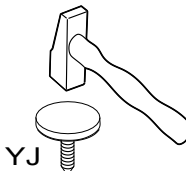

55

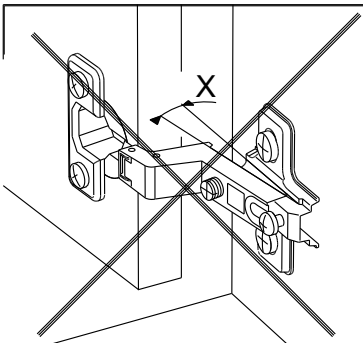
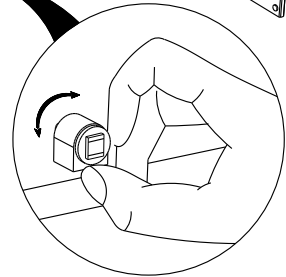
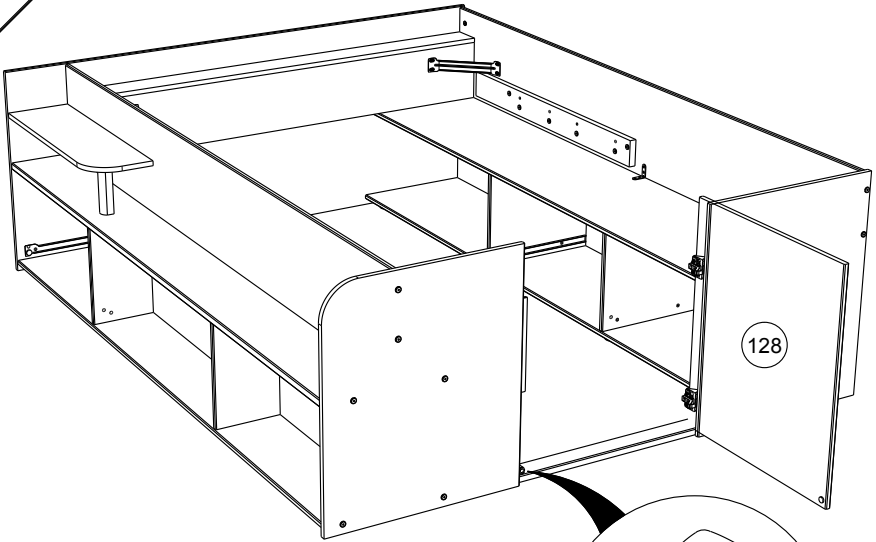

MONTAGE

- Ⓒ GB LEAFLET
- Ⓓ D AUFBAUANLEITUNG
- Ⓔ E MONTAJE
- ⒫ P MONTAGEM
- Ⓖ I MONTAGGIO
- Ⓗ NL MONTAGE

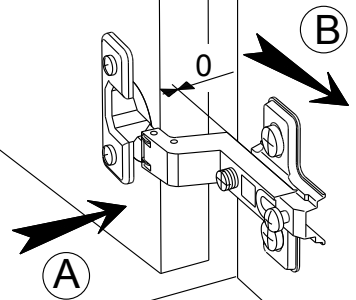

REGLAGE Ⓒ GB ADJUSTING Ⓔ E AJUSTER Ⓖ I AGGIUSTAMENTO
 Ⓓ D ANPASSUNG ⒫ P REGULACAO Ⓗ NL AFSTELLING

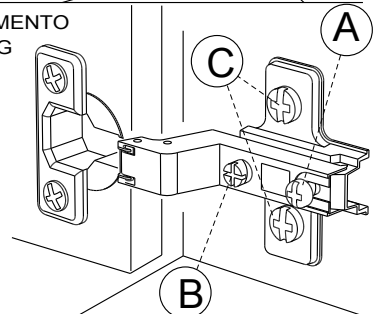
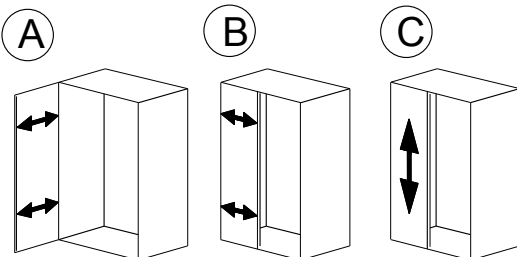

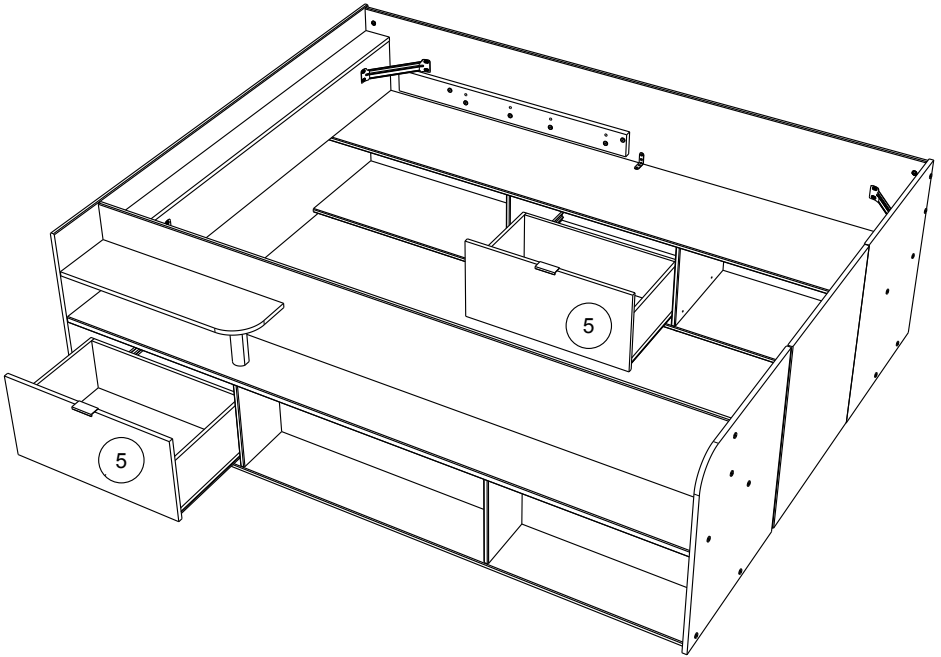

MINI 13Kg / 28.6lb
MAXI 27Kg / 59.5lb

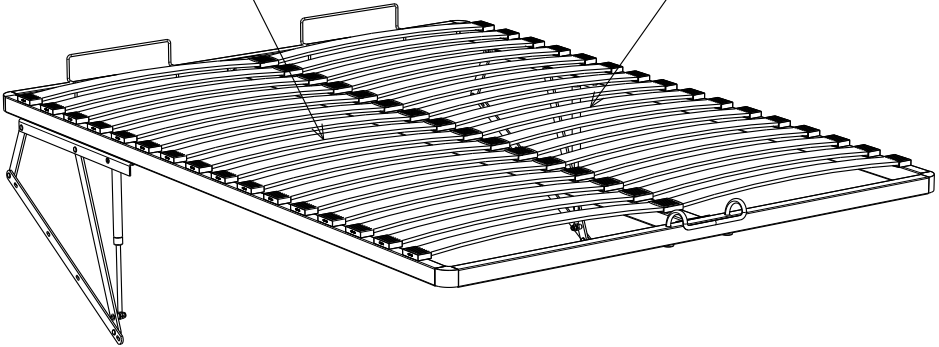
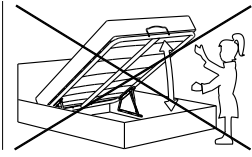
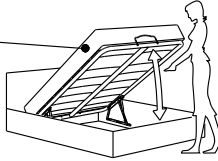

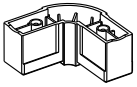

6 x4

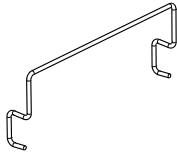

5 x2

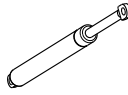

13 x2

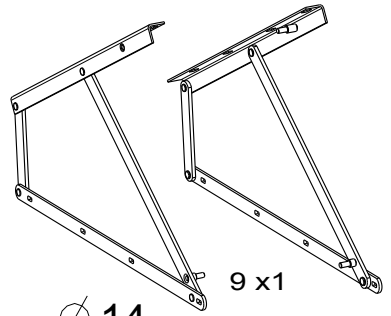

9 x1

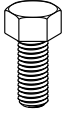

7 x12



18

16 x8



8 x8



14 x4



14

15 x8

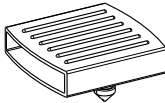

11 x16



10 x32

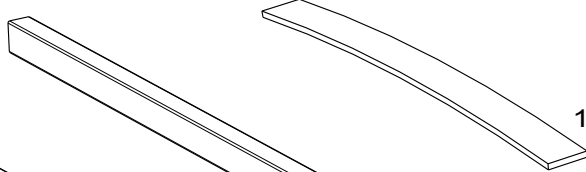

12 x32

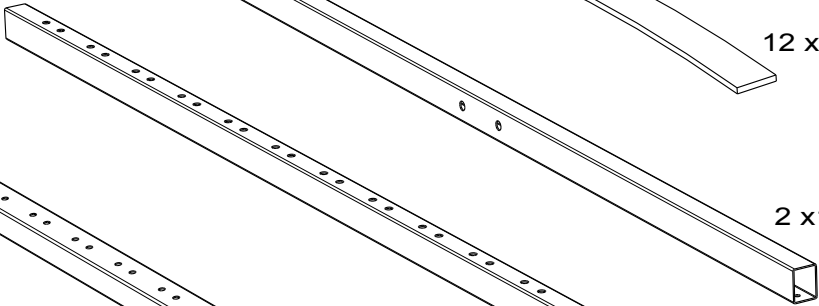

2 x1

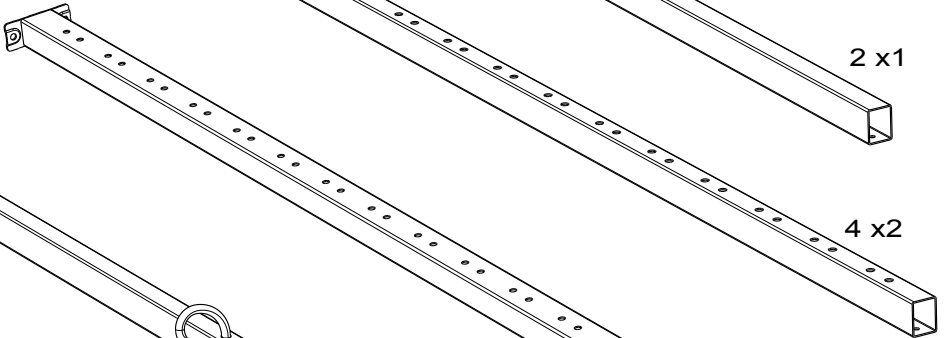

4 x2

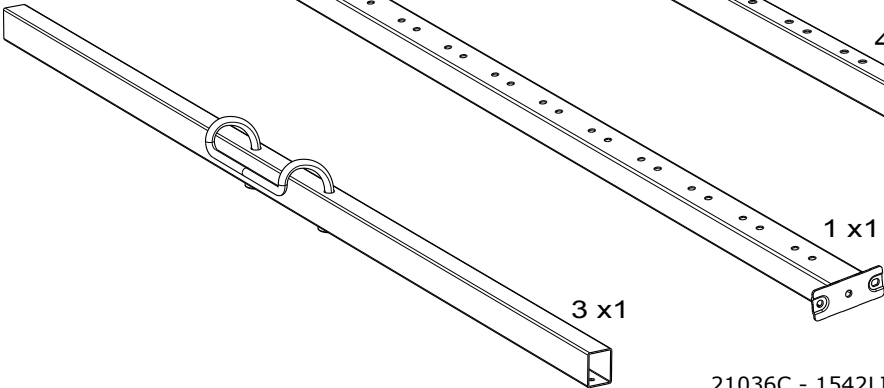

1 x1

3 x1

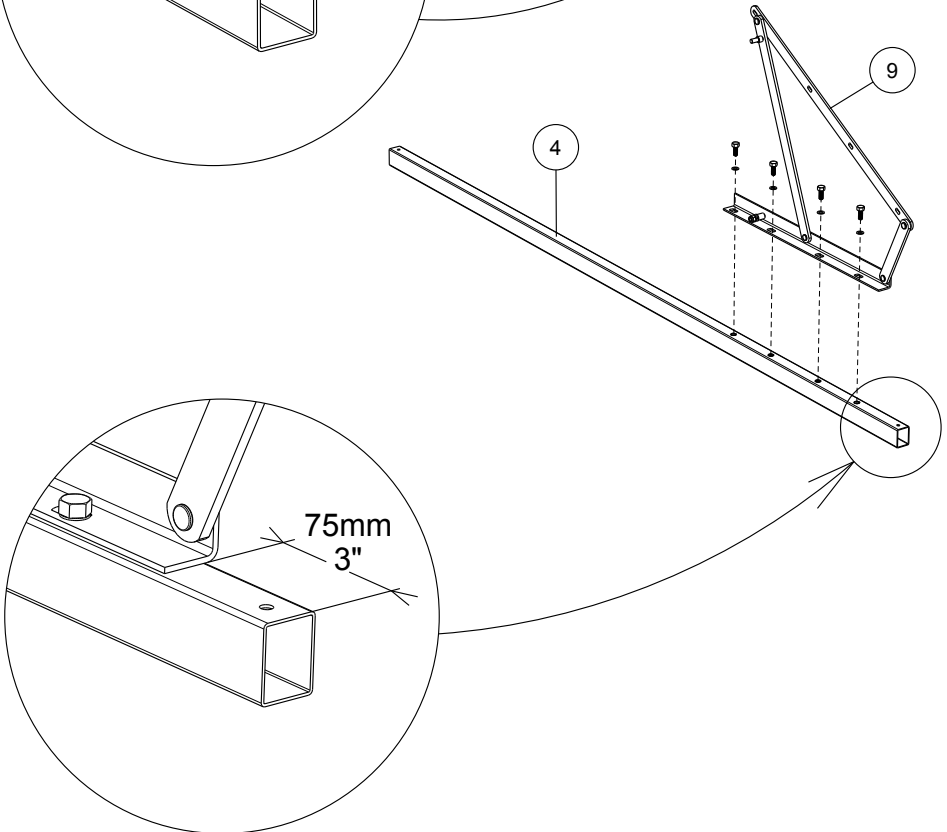
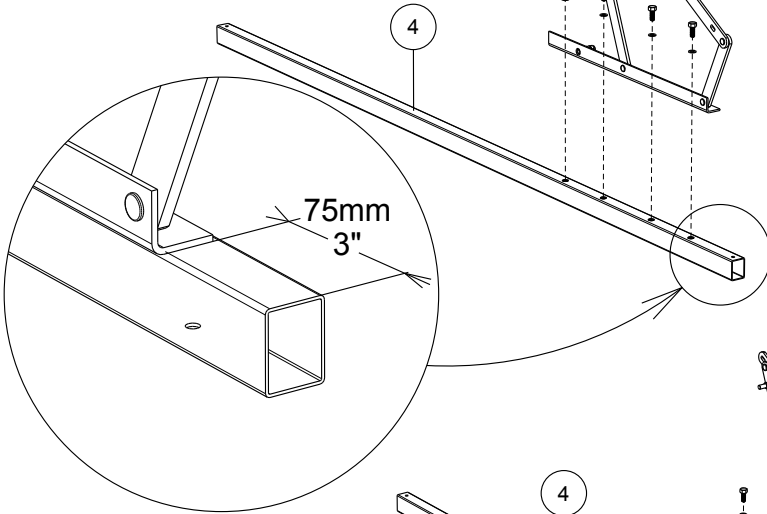
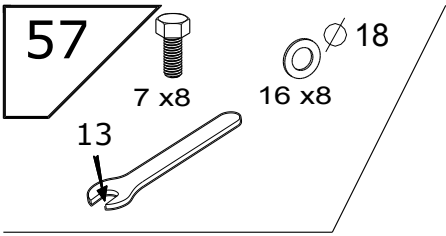

58

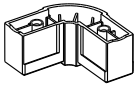

6 x 4



8 x 4

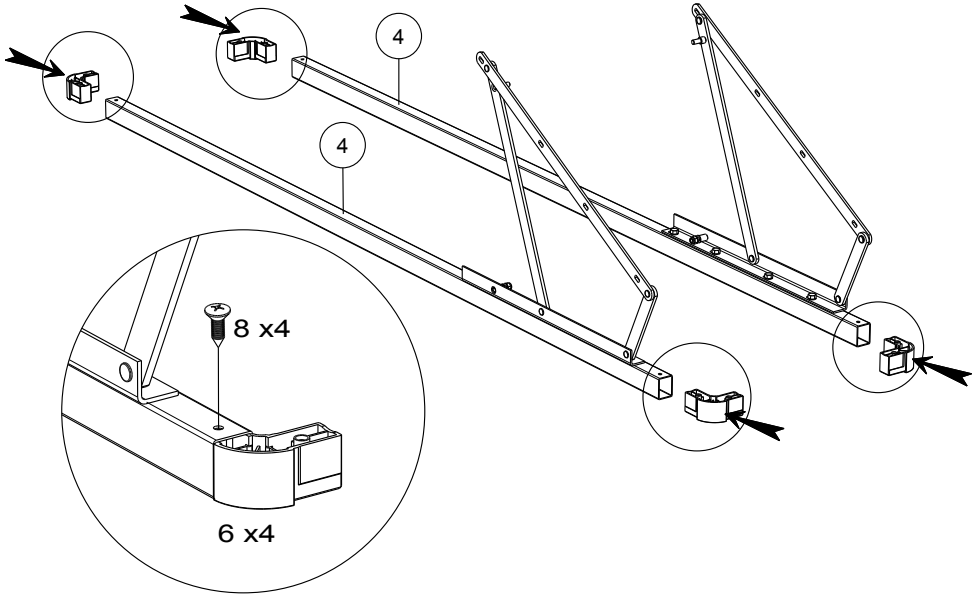

59



7 x 4

13

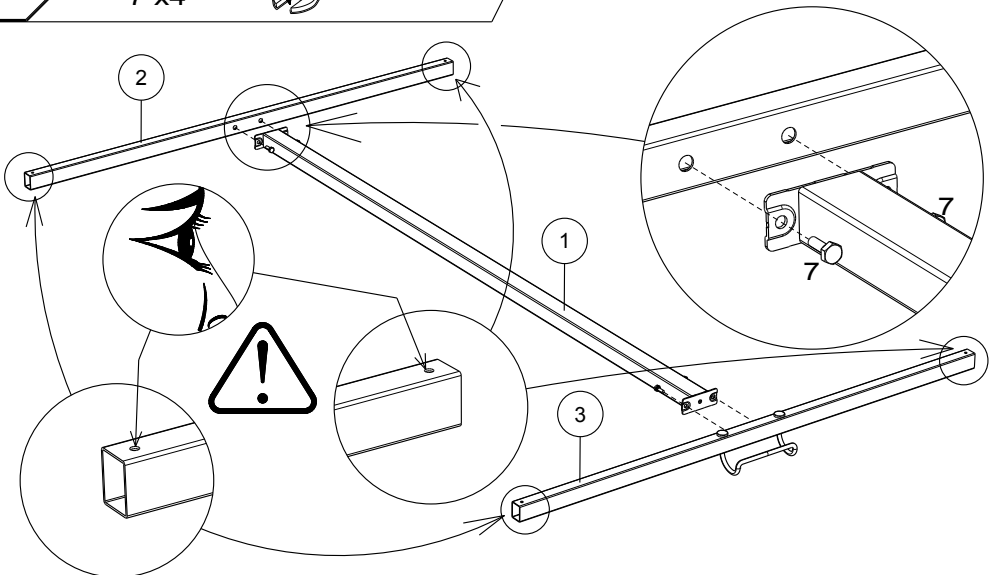

60

8 x 4

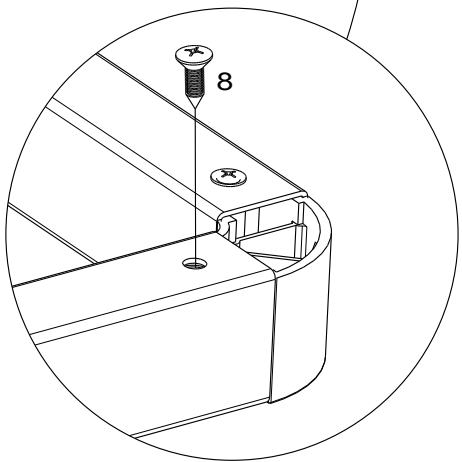
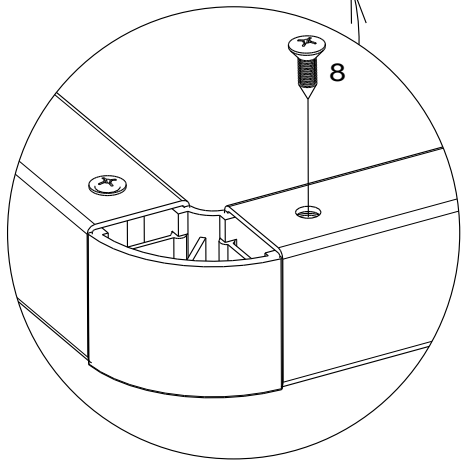
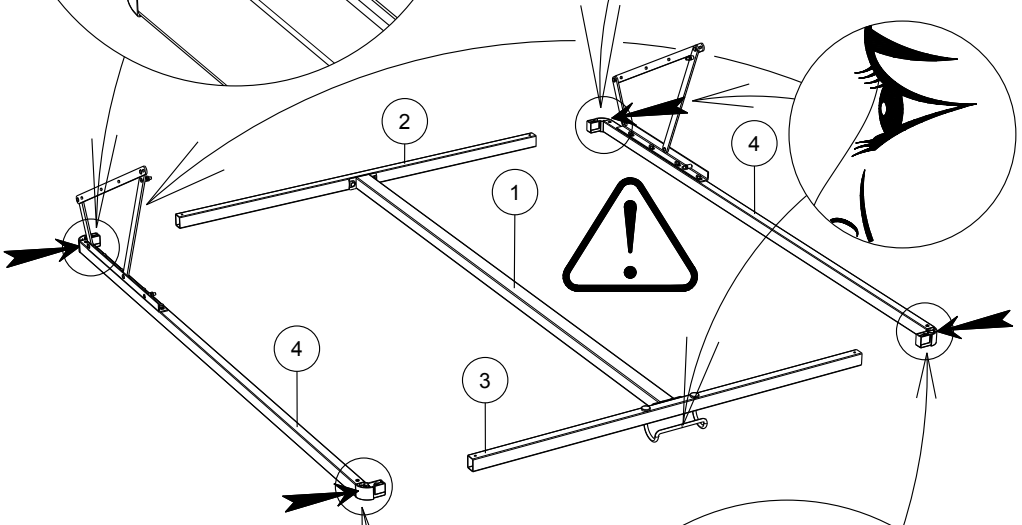
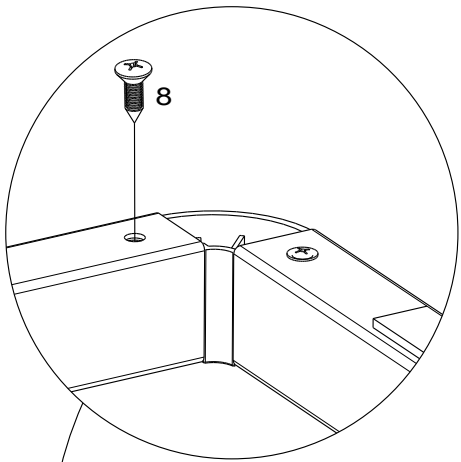
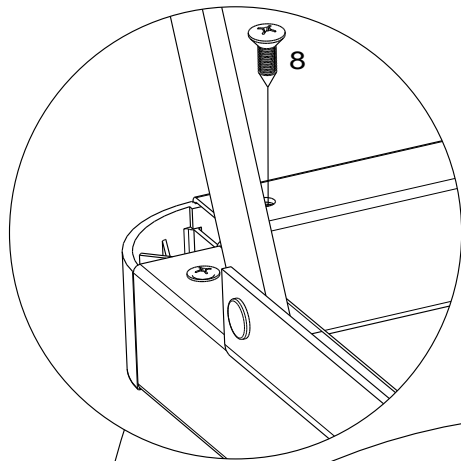

61

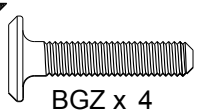

BGZ x 4

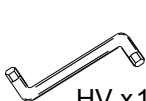

HV x1

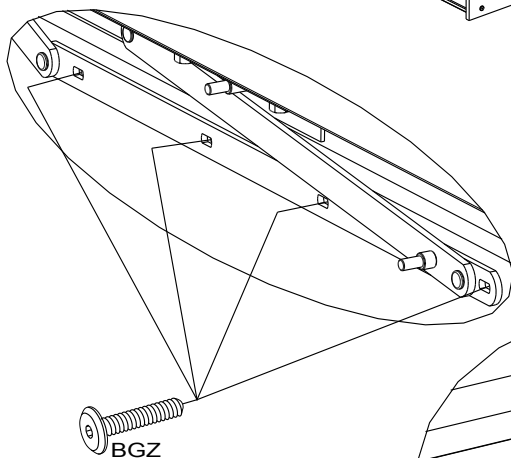
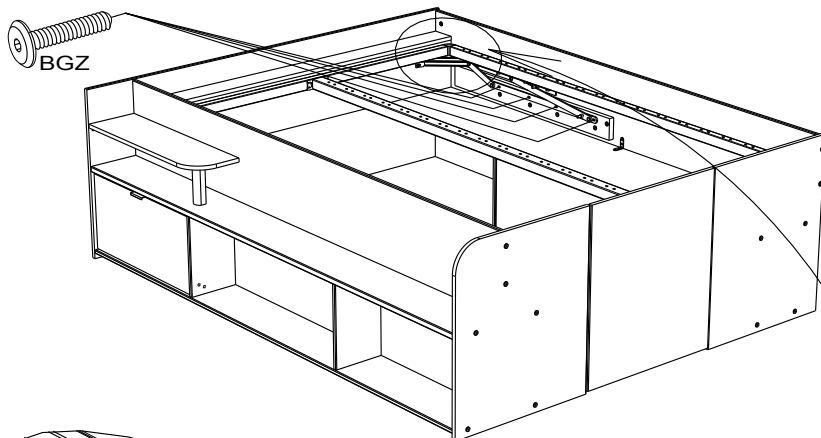

27mm
1 1/4"

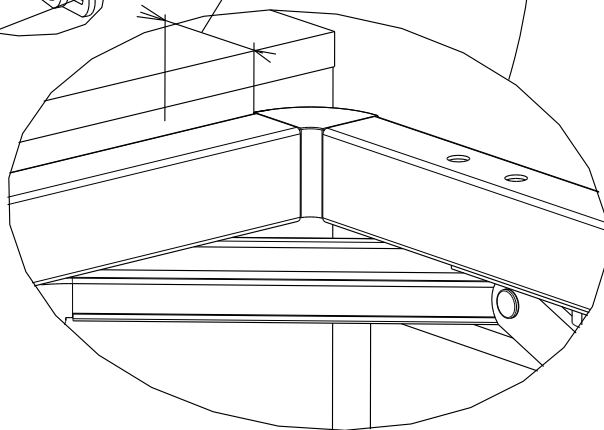

62

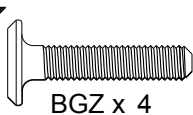

BGZ x 4



HV x1

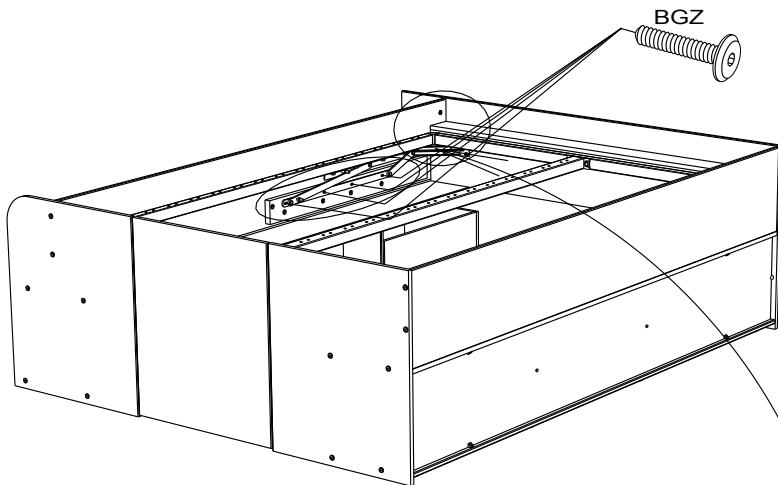

BGZ

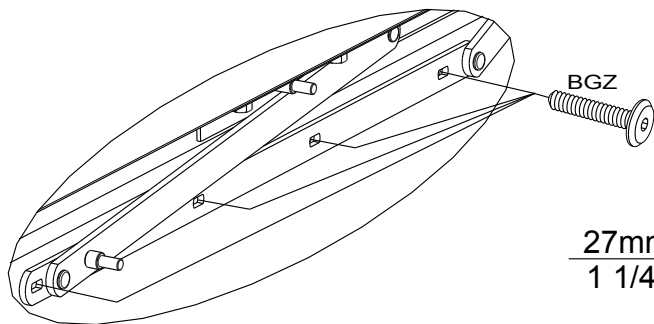

BGZ

27mm
1 1/4"

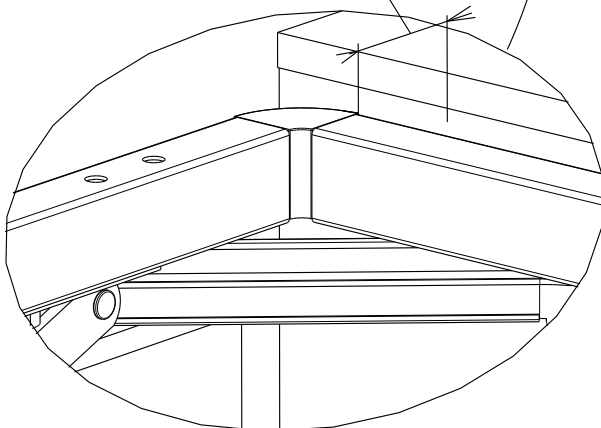

63

5 x2

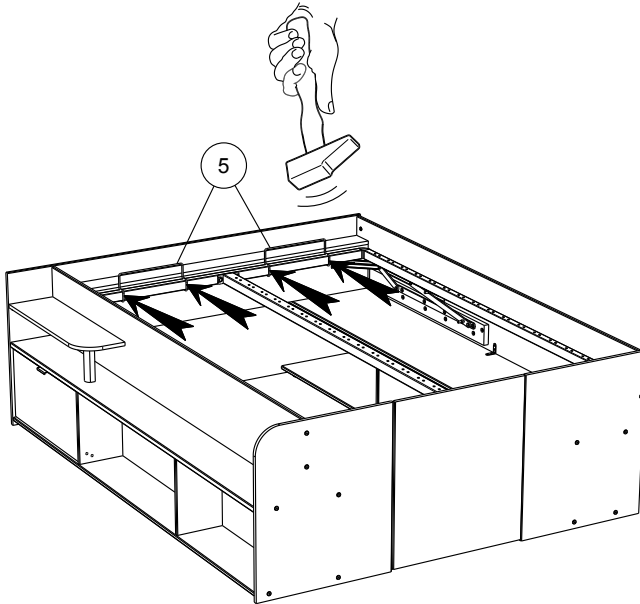
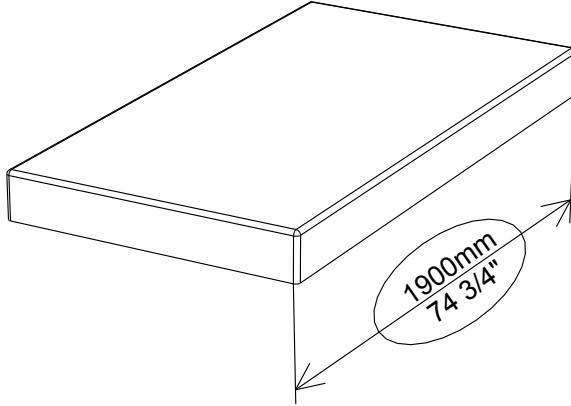
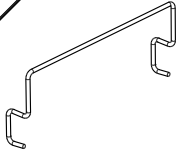

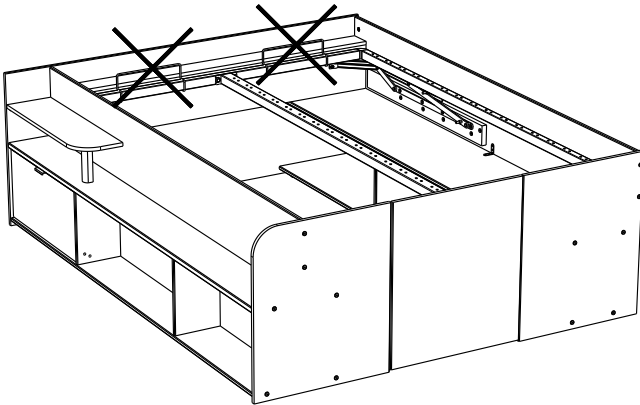
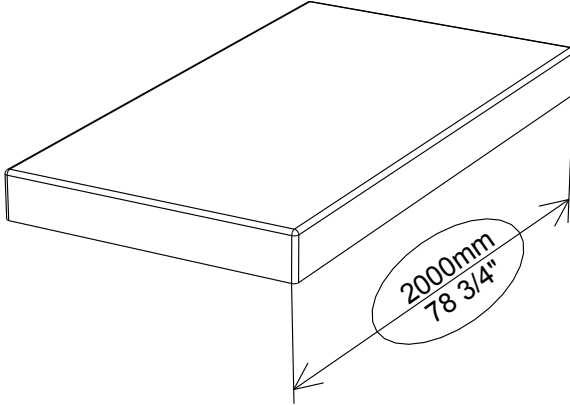
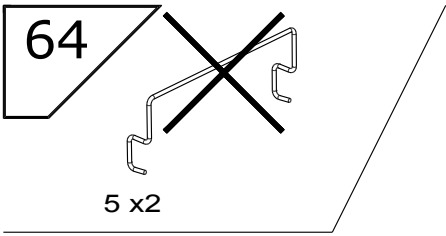

65

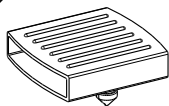

11 x16

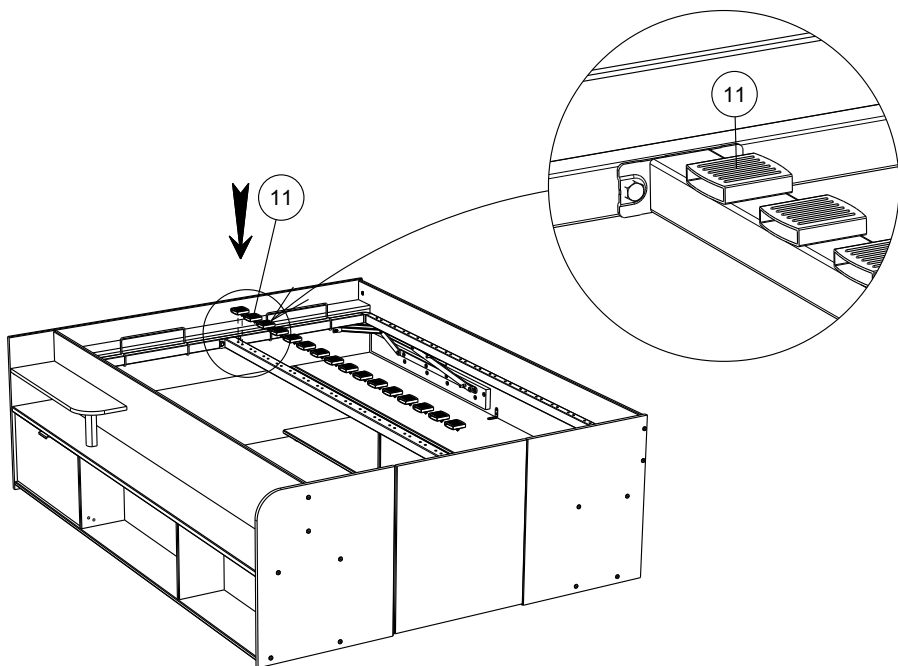

66



10 x 32

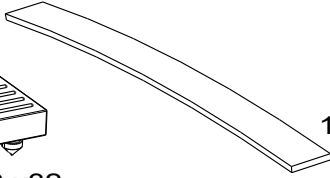

12 x 32

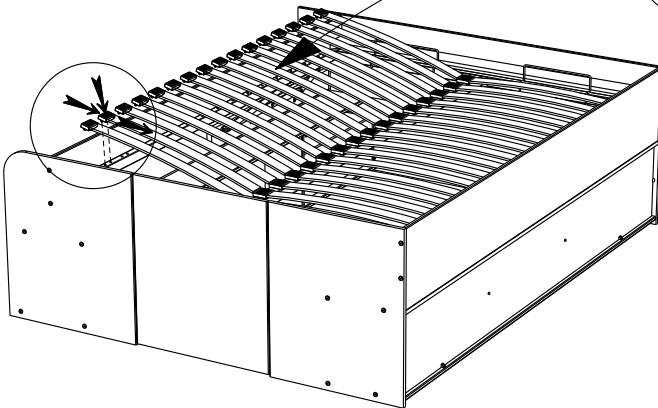
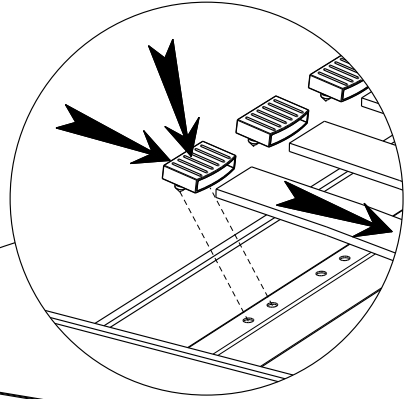
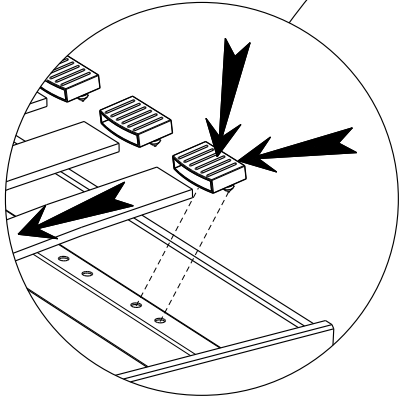
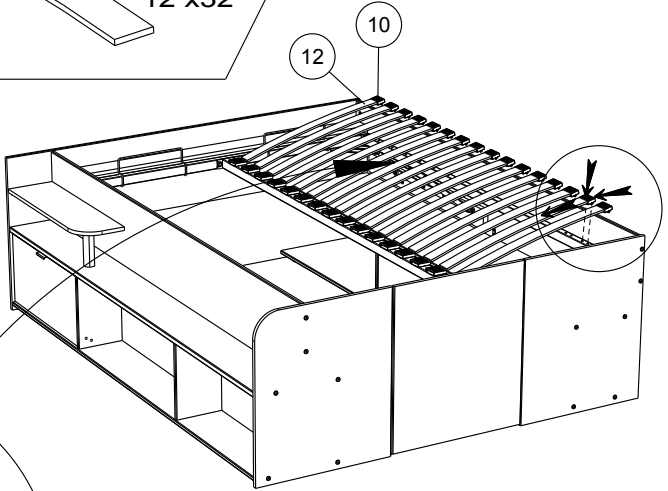

67

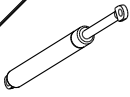

13 x 1

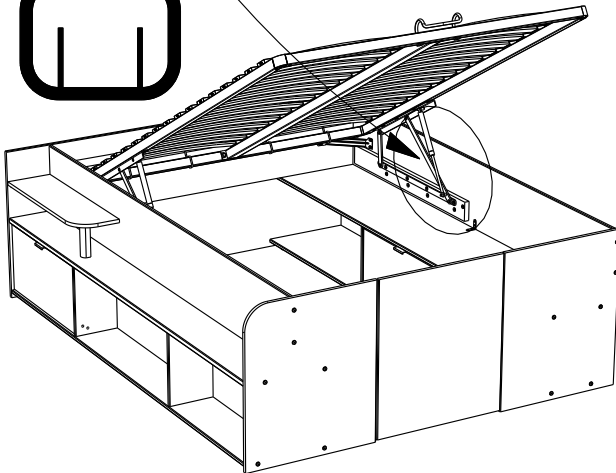
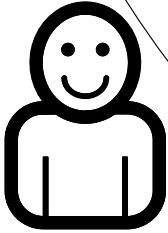
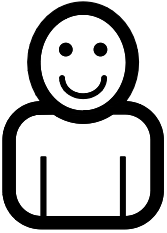
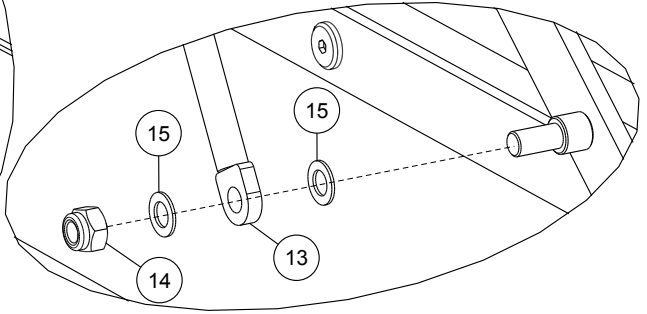
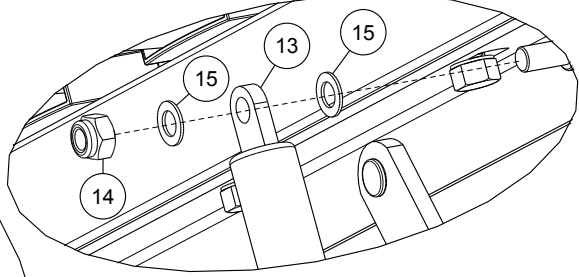
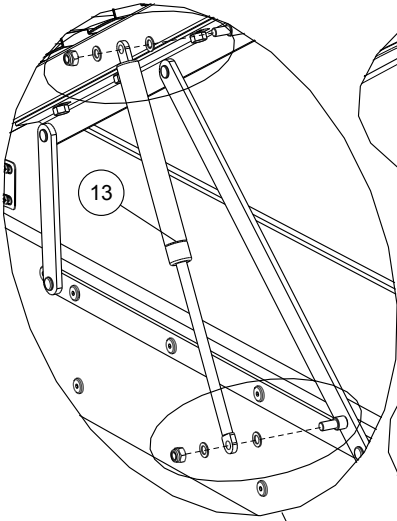

68

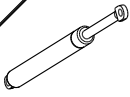

13 x 1

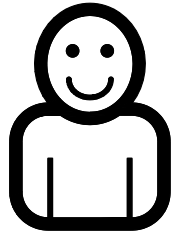
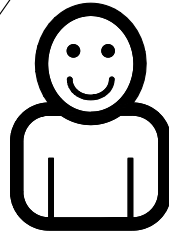
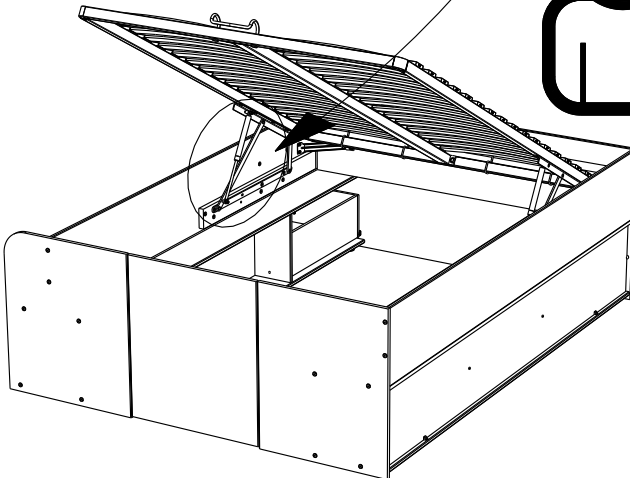
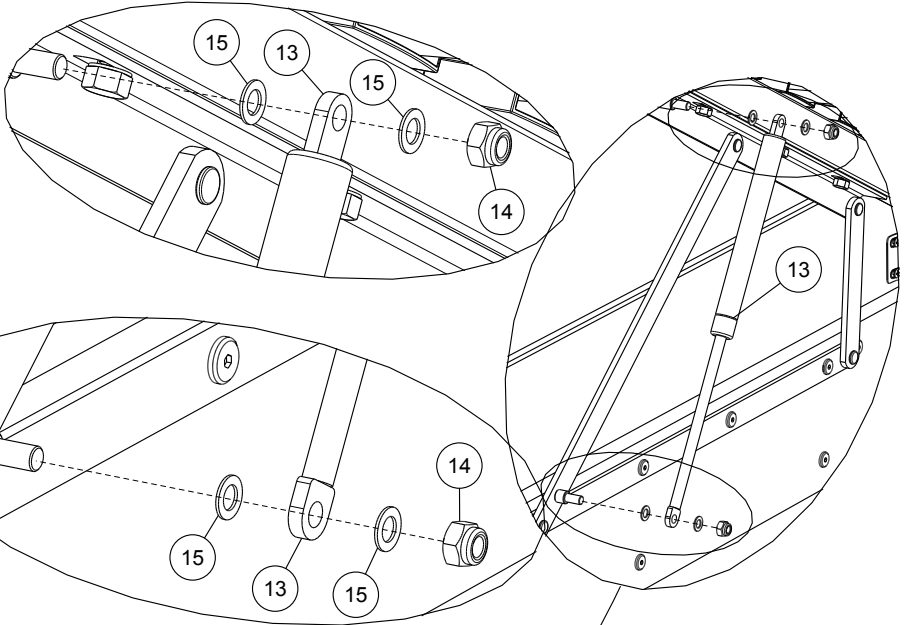

69

MINI 13Kg / 28.6lb
MAXI 27Kg / 59.5lb

