

SZAFA 203 WARDROBE 203 SCHRANK 203

- | | | | |
|----|-----------------------------|----|--------------------------|
| Ⓓ | Montageanleitung | ⒼⒷ | Assembly Instructions |
| ⒶⓃ | Handleiding voor de montage | ⒶⓁ | Instrukcja montażu |
| ⒶⓇ | Montaj talimatı | ⒶⓇ | Инструкция по монтажу |
| Ⓐ | Notice de montage | ⒶⓉ | Istruzioni di montaggio |
| ⒸⓏ | Montážní návod | ⒶⓀ | Návod na montáž |
| ⒶⓇ | Szerelési útmutató | ⒶⓇ | Instrucțiunile de montaj |

WYMIARY ELEMENTÓW PART GUIDE MASSE DER BAUTEILE

No.	L[mm]	W[mm]	T[mm]	Stc.
1	2000	564	16	1
2	2000	581	16	1
3	585	2150	16	1
4	585	2150	16	1
5	474	1644	16	1
6	474	1644	16	1
7	2000	474	16	1
8	474	357	16	1
9	2000	100	16	2
10	1009	2050	3	2
11	365	474	16	3
12	480	474	16	3
13	1010	1994	16	1
14	1010	1994	16	1
15	2000	70	16	1
16	2150	38	22	2

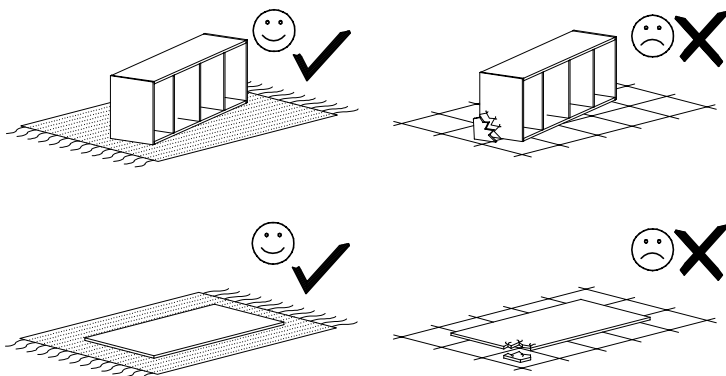
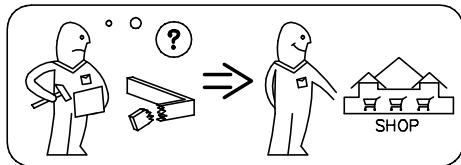
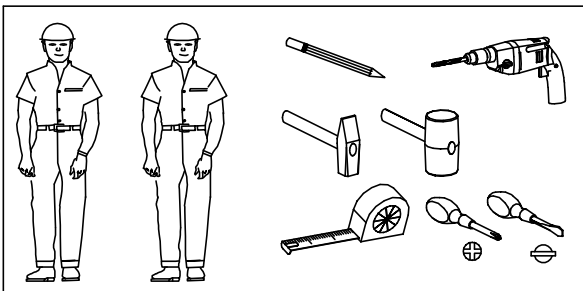
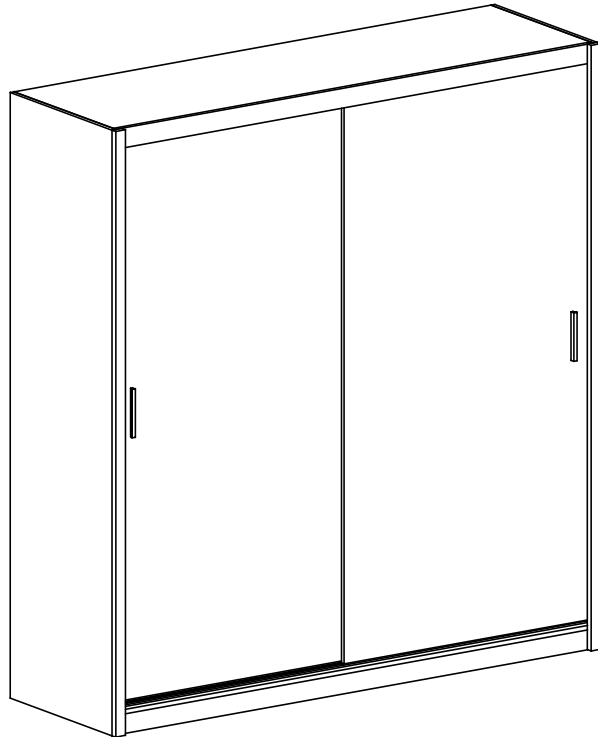

Uwaga – Upozorneni – Achtung – Attention – Caution – Figyelem Attenzione – Opgelet – Внимание – Atentie – Upozornenie – Dikkat

ⒶⓁ	Czyszczenie należy wykonać wyłącznie za pomocą ściereczki lub lekko nawilżonego ręcznika. Nie stosować środków czyszczących do szorowania.
ⒸⓏ	Čistění je nutné vykonávat výhradně pomoci utěrky nebo lehce navlhčeného ručniku. Nepoužívejte čističí prostředky obsahující abrazivní částice.
Ⓓ	Bitte nur mit einem Staubtuch oder leicht feuchtem Lappen reinigen. Keine scheuernden Putzmittel verwenden.
ⒼⒷ	Please only clean with duster or damp cloth. Do not use any abrasive cleaners.
Ⓐ	Le nettoyage se fait uniquement à l'aide d'un torchon ou d'une serviette légèrement mouillée.
ⒶⓇ	A tisztítás kizárólag törölrüha vagy enyhén nedvesített törölköző segítségével végezhető. Súroló hatású tisztítószerket nem szabad használni.
Ⓐ	Pulire esclusivamente con un panno o un asciugamano umido.
ⒶⓃ	Reinig allen met een stofdoek of een lichtjes vochtige doek. Gebruik geen schurende poetsmiddelen.
ⒶⓇ	Очищайте от пыли тряпкой или слегка влажной ветошью. Не допускаются применение чистящих средств, не пред-назначенных для ухода за мебелью.
ⒶⓇ	Curabare trebuie efectuată numai cu o cârpă sau cu un prosop usor umzeit. Nu utilizati agenți de curabare abrazivi.
ⒶⓀ	Čistení je nutné vykonávat výhradně pomoci utěrky nebo l'ahko zvlhnutým ručnikom. Nepoužívejte čističí prostriedky obsahujúci abrazivní částice.
ⒶⓇ	Lütfen sadece bir toz bezile veya hafif nemli yumusak bir bezle siliniz. Asindirici temizlik malzemeleri kullanmayiniz.

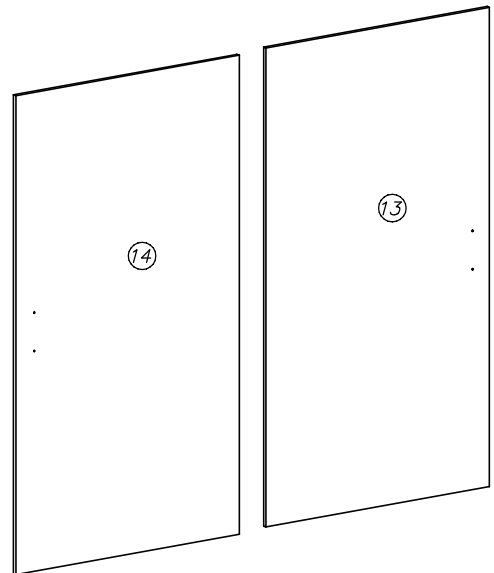
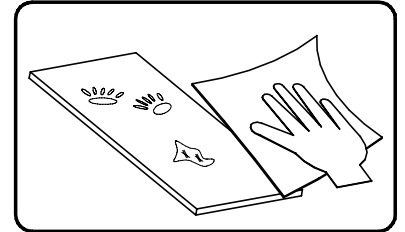
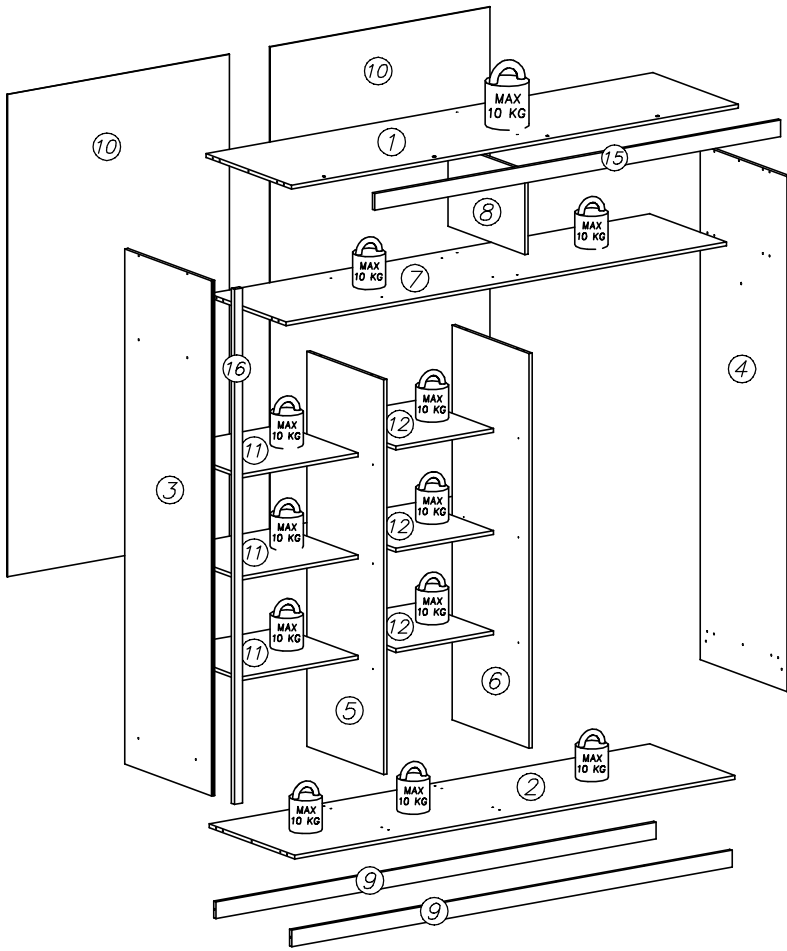
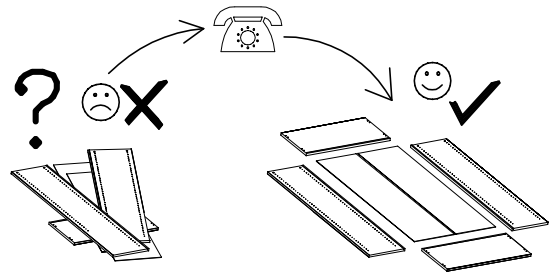
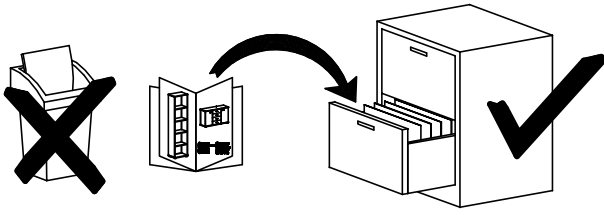

W9

OSWIETLENIE LED OPCJONALNIE
 OPTIONAL LED LIGHTING
 WAHLWEISE LED-BELEUCHTUNG

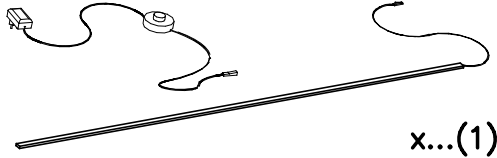

x...(1)

T9



x...(8)

T1



x...(2)



G20



5x13

x...(8)

T20



x...(2)

T13



x...(12)

W1



x...(1)

T19



x...(2)

F1



x...(24)

P4



x...(8)

G11



4x20 x...(4)

S1

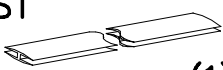

x...(1)

E10

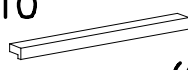

x...(2)

G8



4x30 x...(4)

T5



x...(4)

K1



Ø15x12 x...(4)

I12



x...(4)

S5



x...(2)

W4



x...(100)

G31



4x13 x...(16)

T4



x...(4)

K5

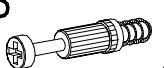

x...(4)

I17



x...(24)

A1



Ø7x50 x...(24)

B1



Ø8x35 x...(36)

S18



x...(4)

W2



x...(1)

G19



6x13 x...(16)

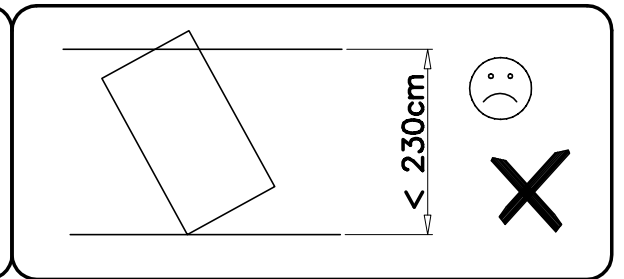
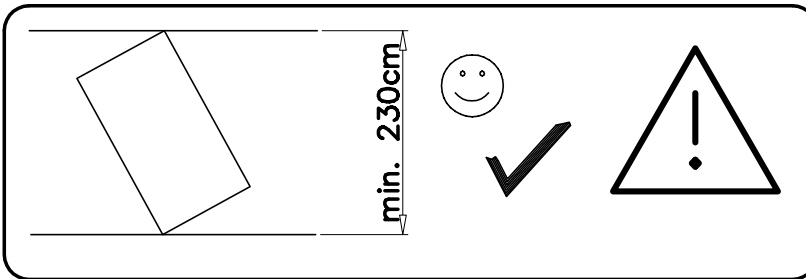
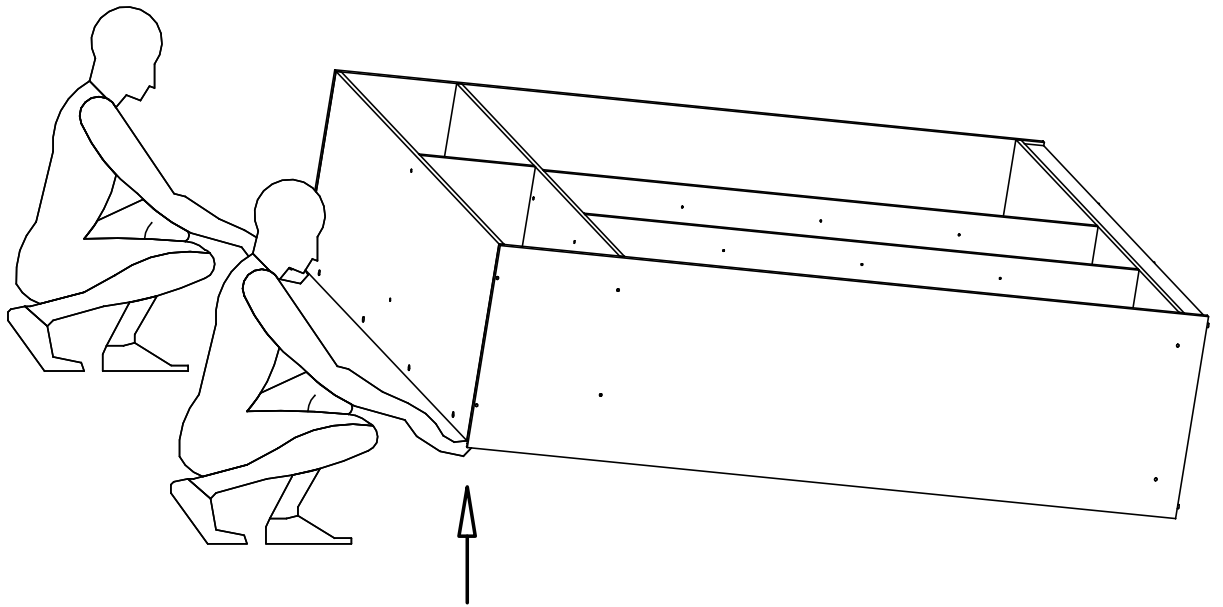

I

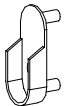

S18  x...(2)

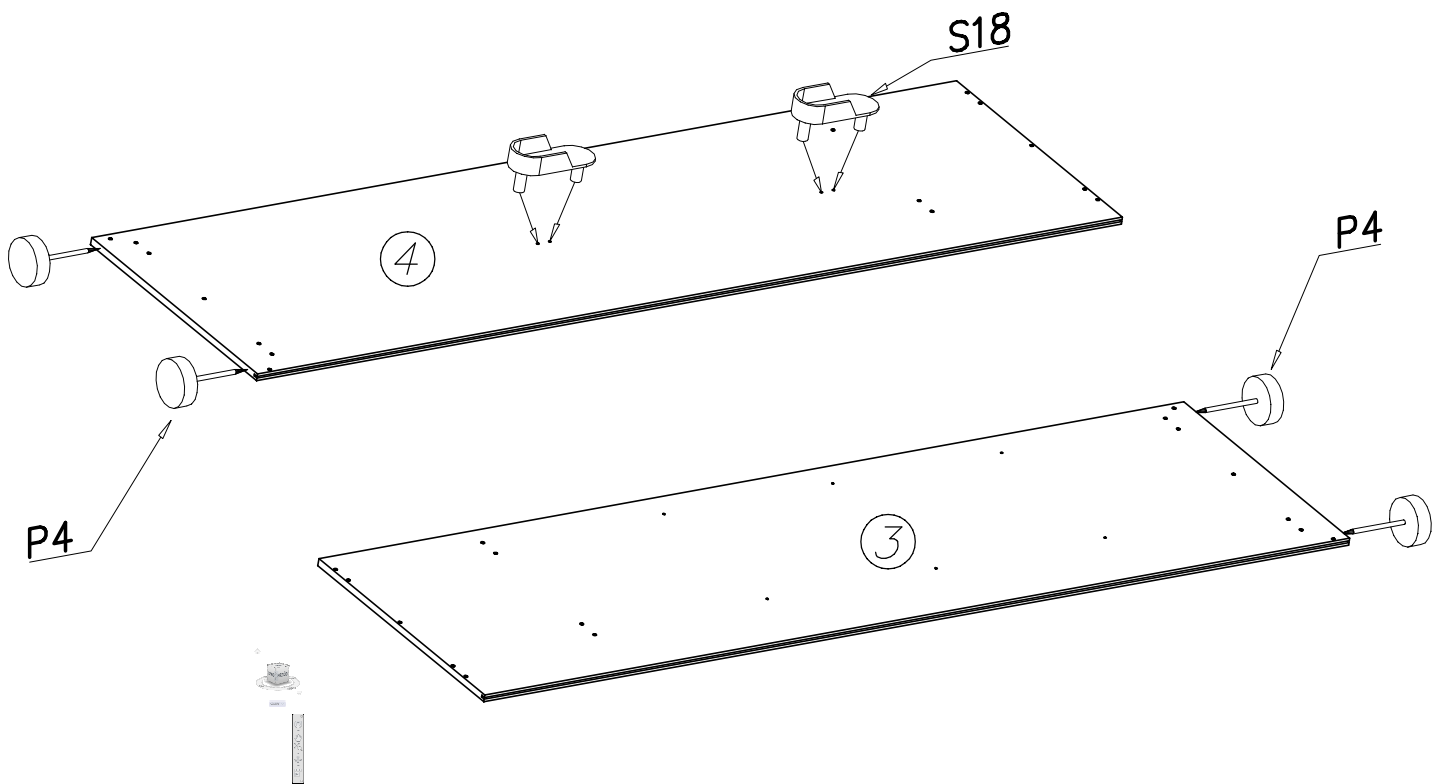
P4  x...(4)



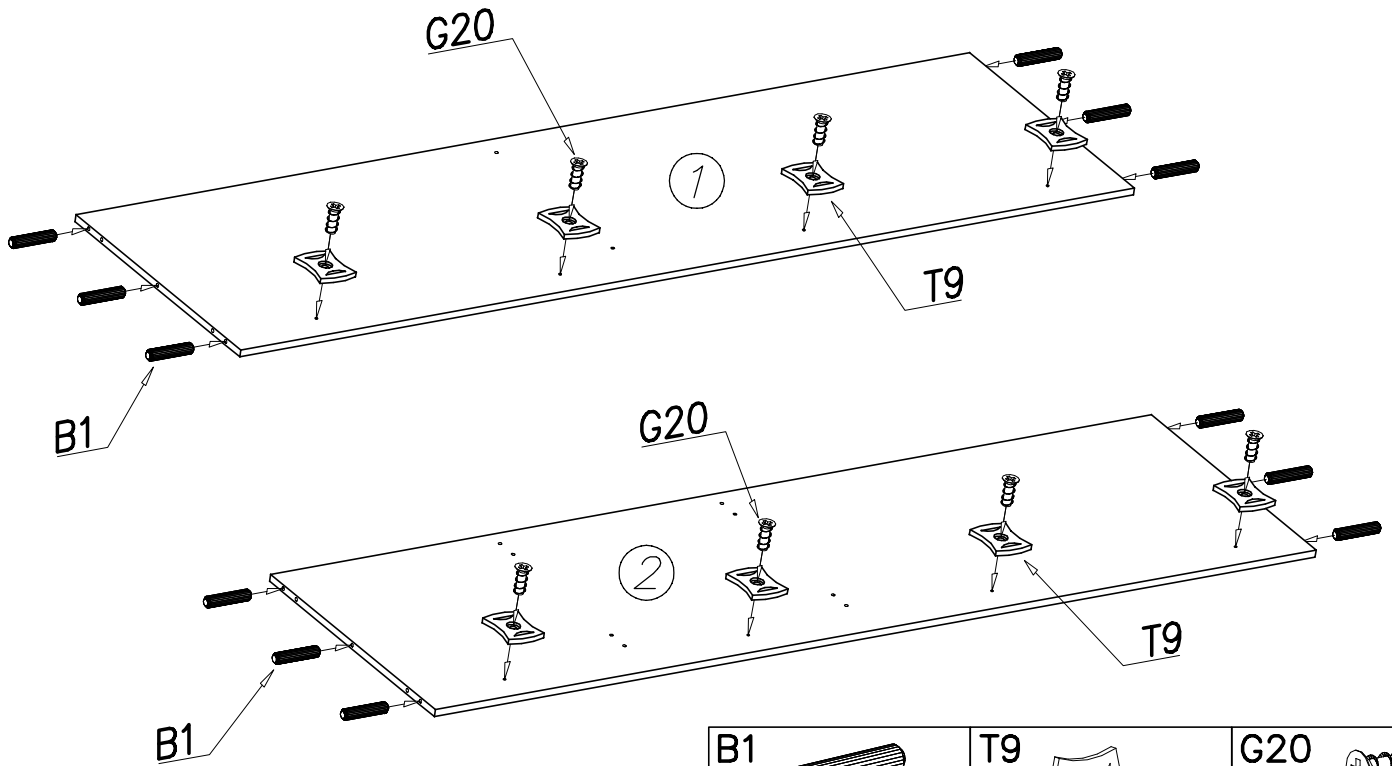
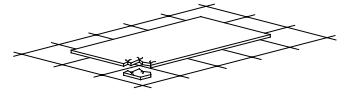
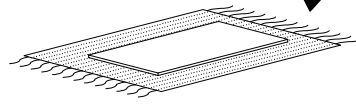

II



B1  $\varnothing 8 \times 35$ x...(12)	T9  x...(8)	G20  5×13 x...(8)
---	--	---

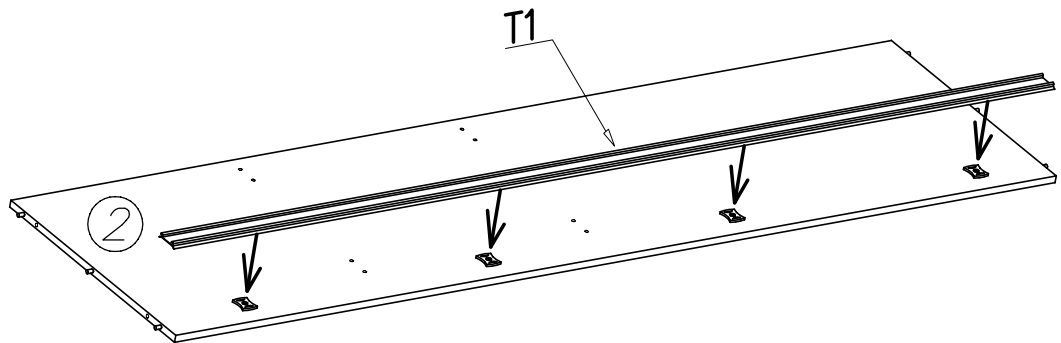
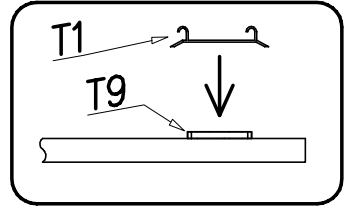
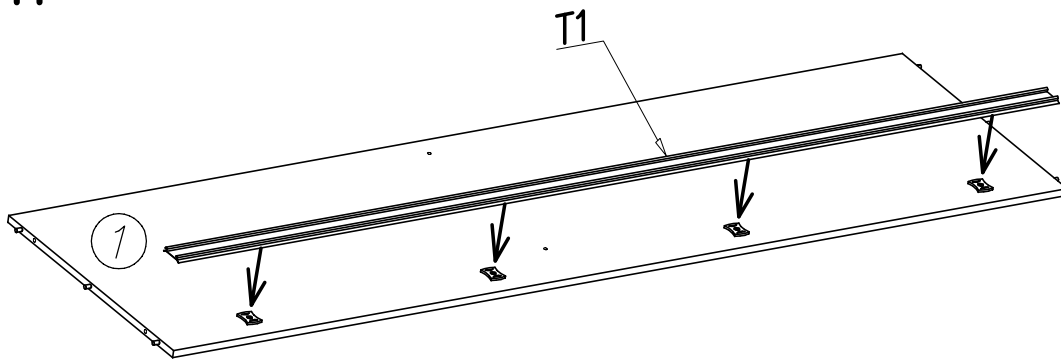

III

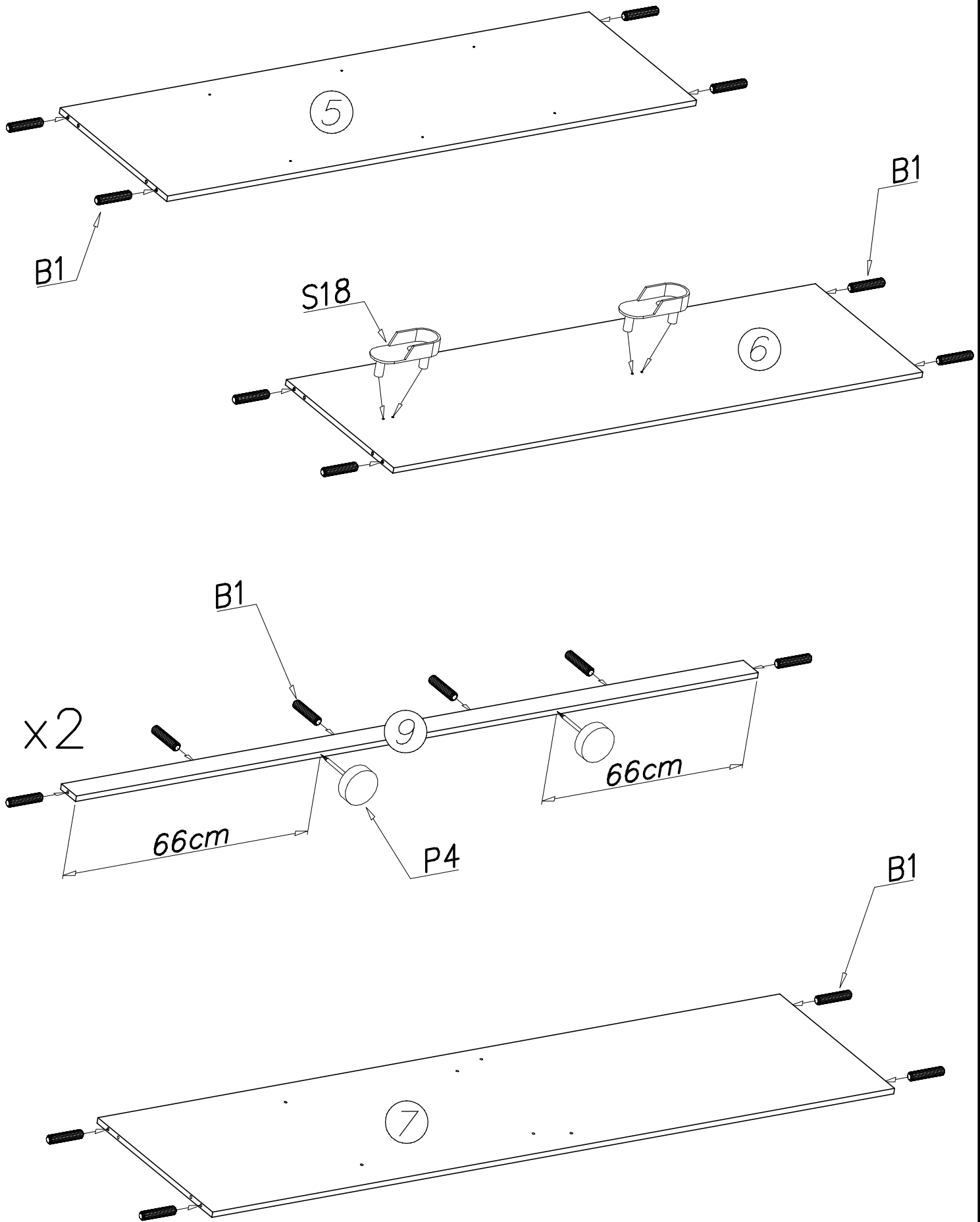

T1  x...(2)
--

IV



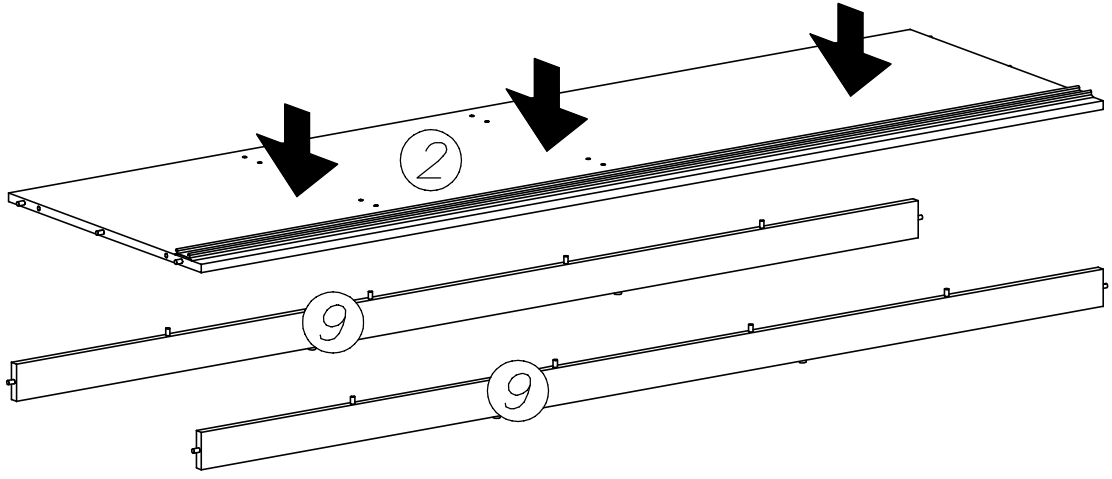

<p>S18</p>  <p>x...(2)</p>	<p>B1</p>  <p>∅8x35 x...(24)</p>
---	---

V



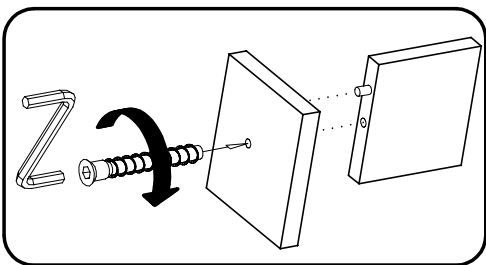
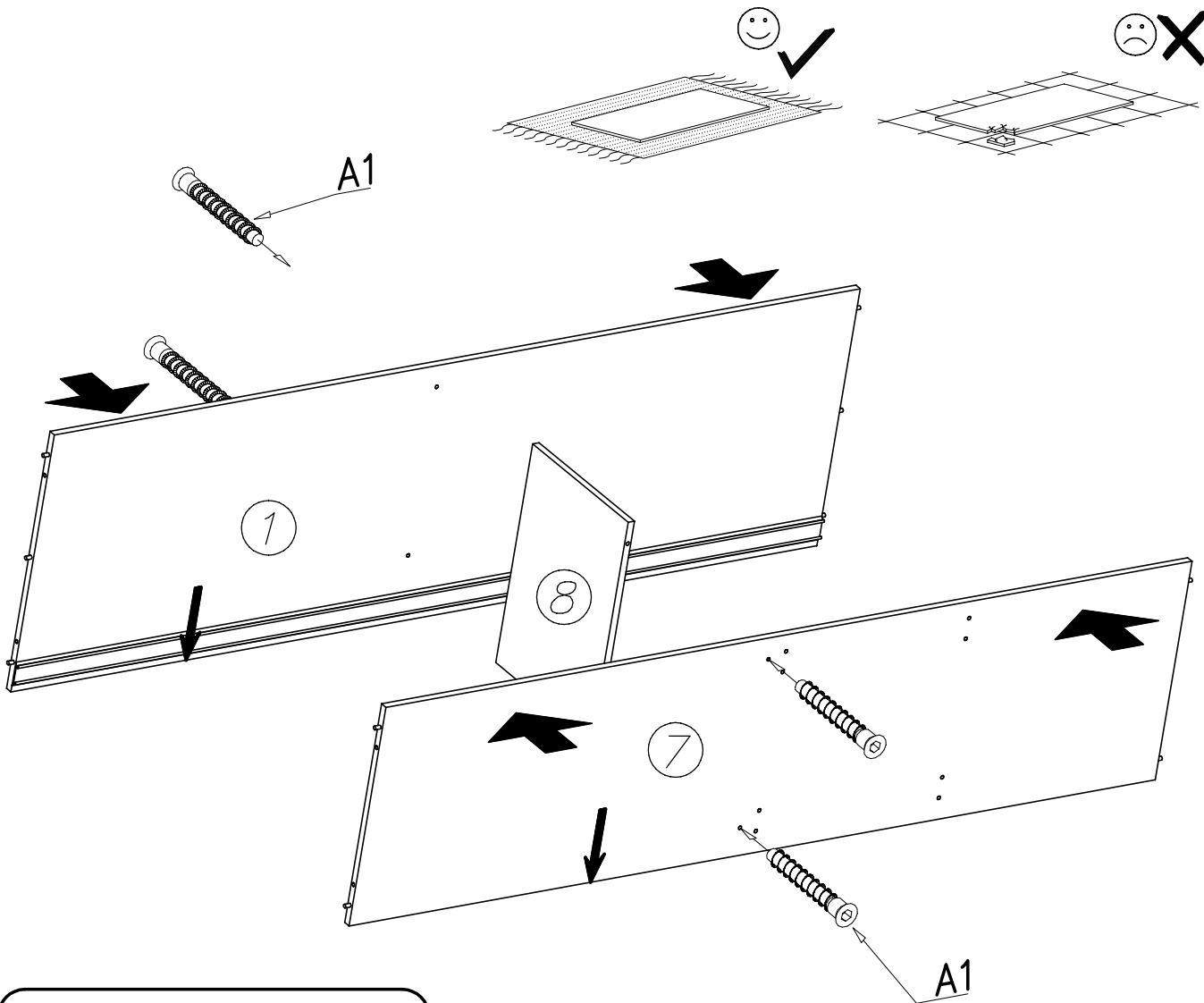

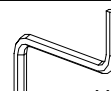
VI



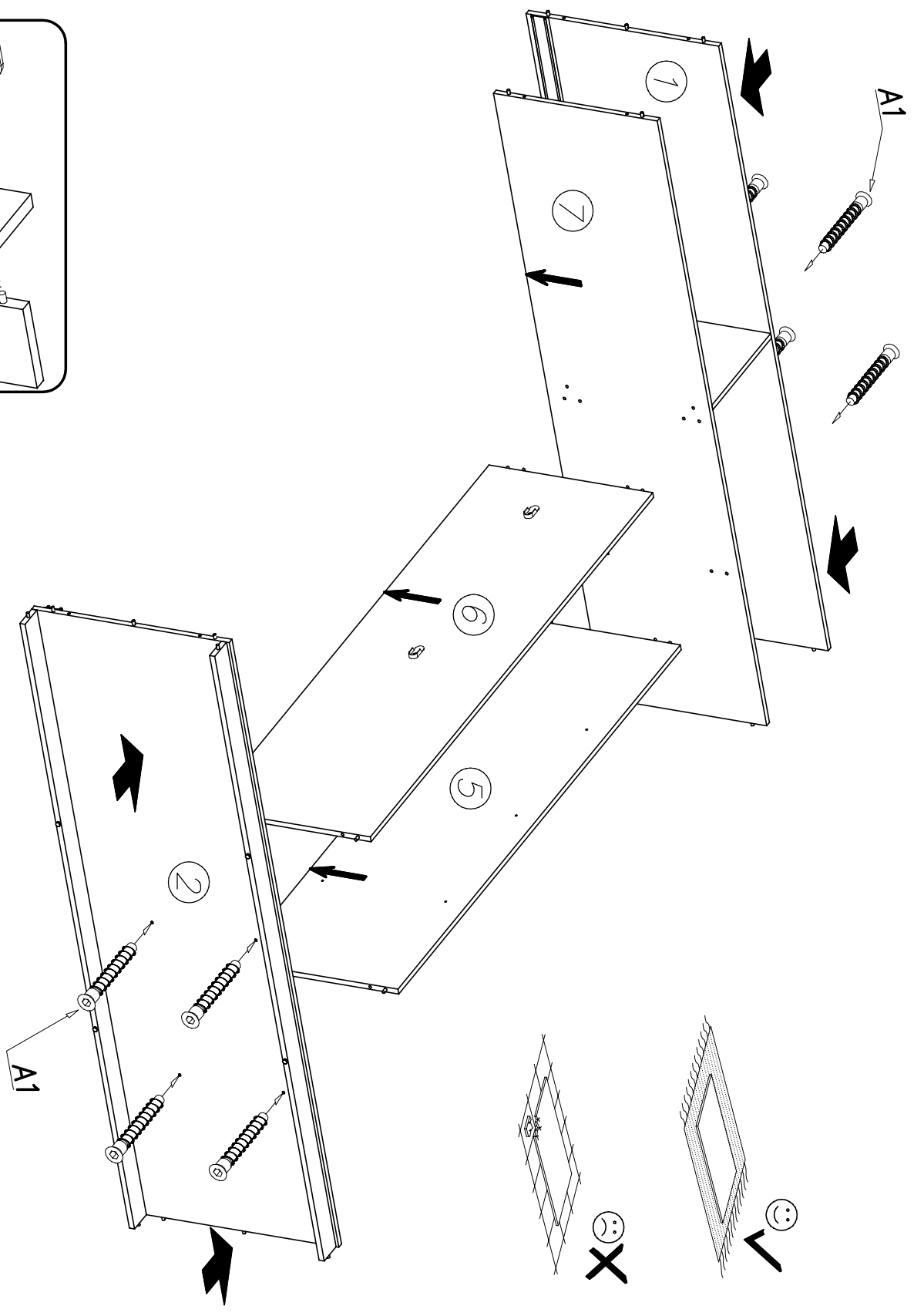
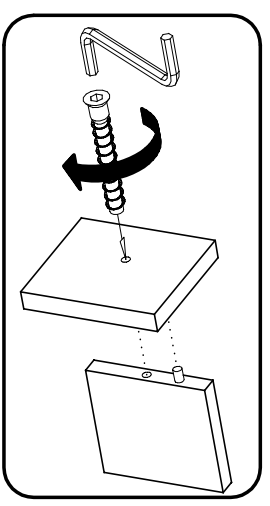

<p>W2</p>  <p>x...(1)</p>	<p>A1</p>  <p>ø7x50 x...(4)</p>
--	--

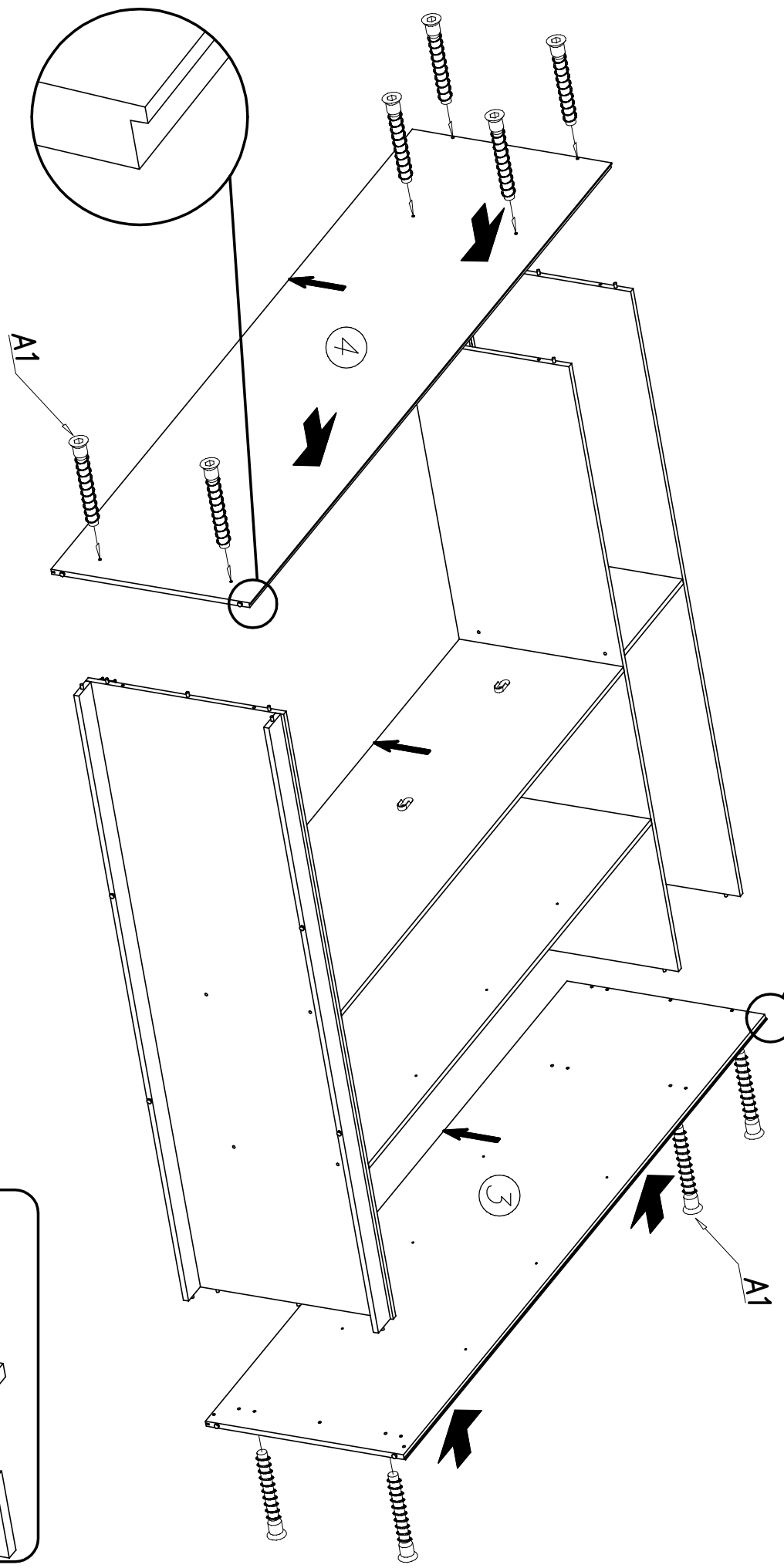
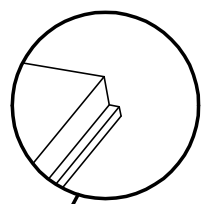
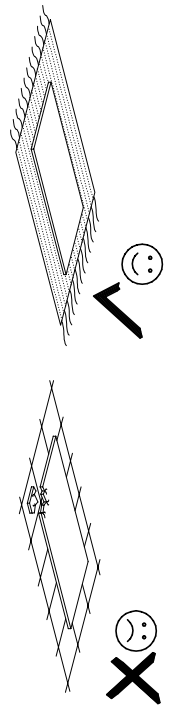

W2		A1	
	x...(1)	ø7x50	x...(8)



<p>W2</p>  <p>x... (1)</p>	<p>A1</p>  <p>∅7x50 x... (12)</p>
--	---

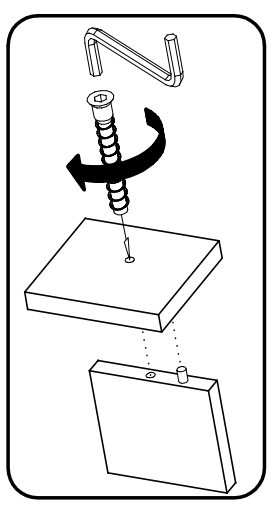

IX

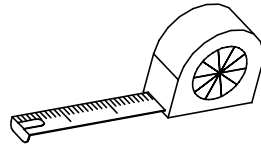
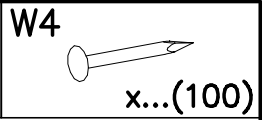
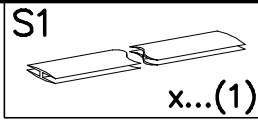
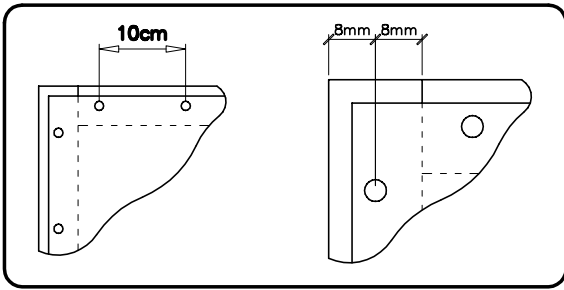

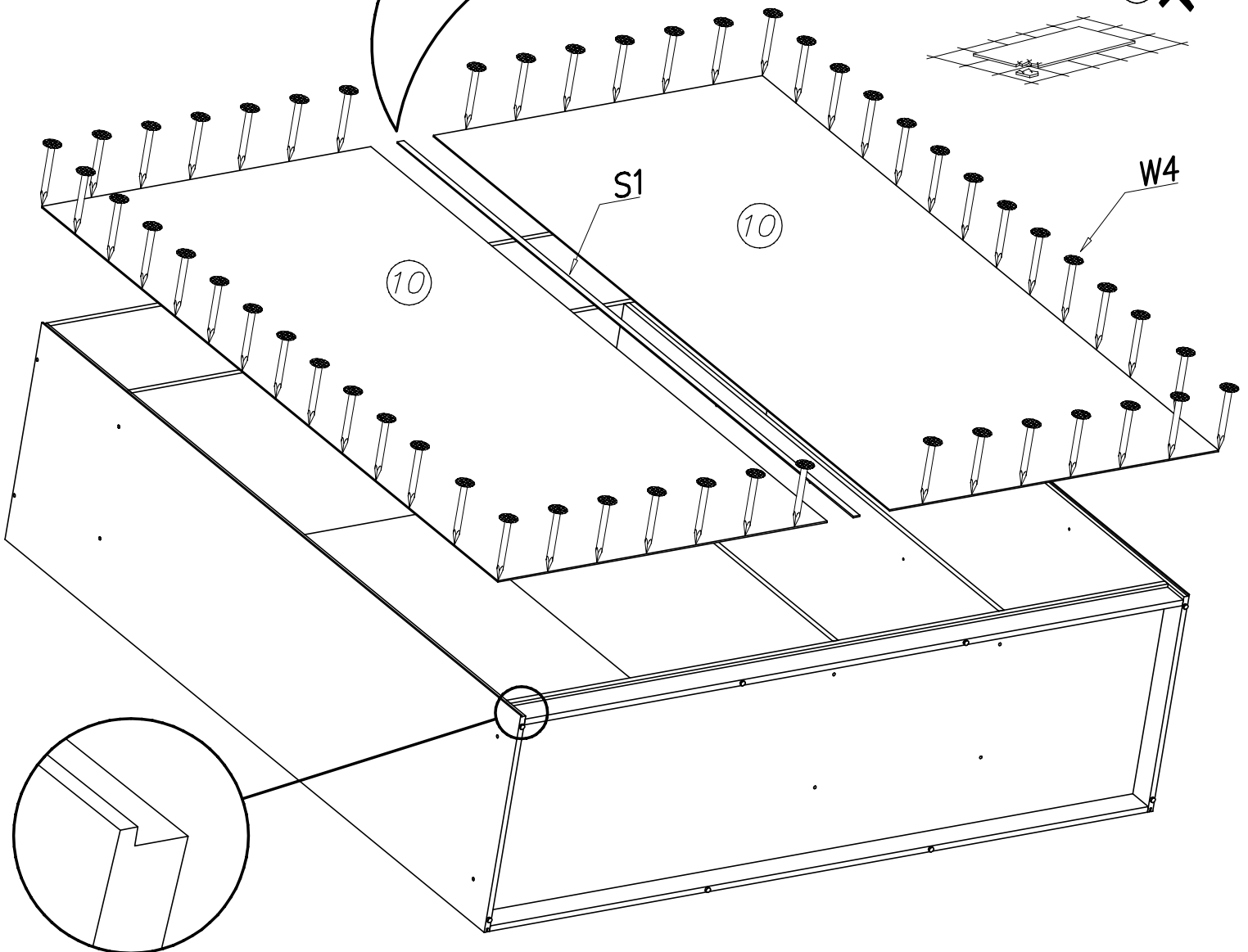
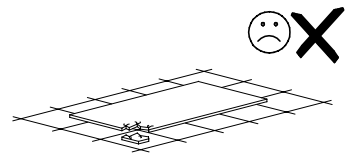
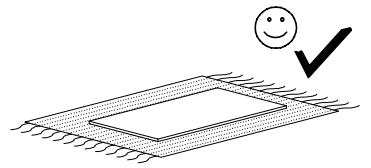
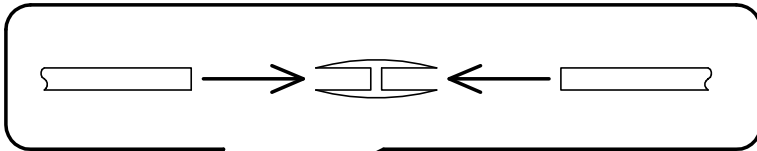
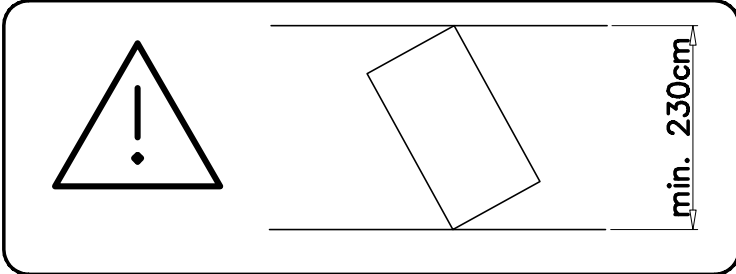
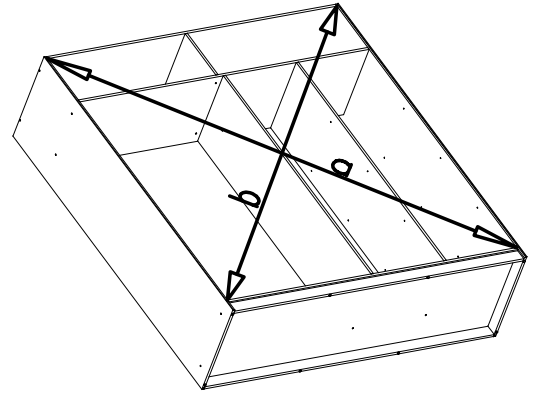

$a = b$



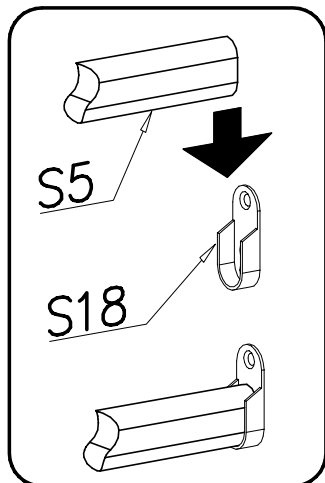
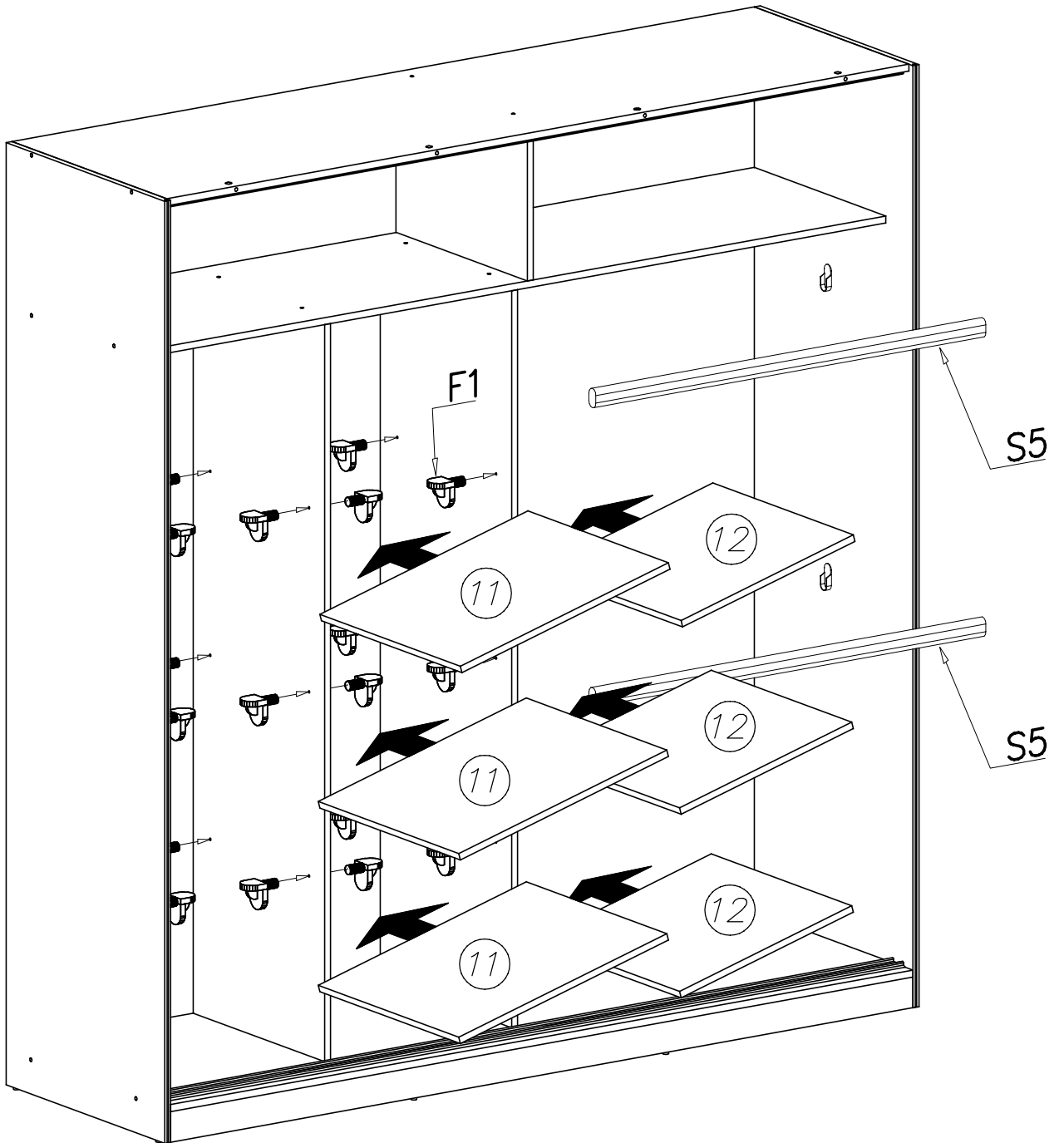





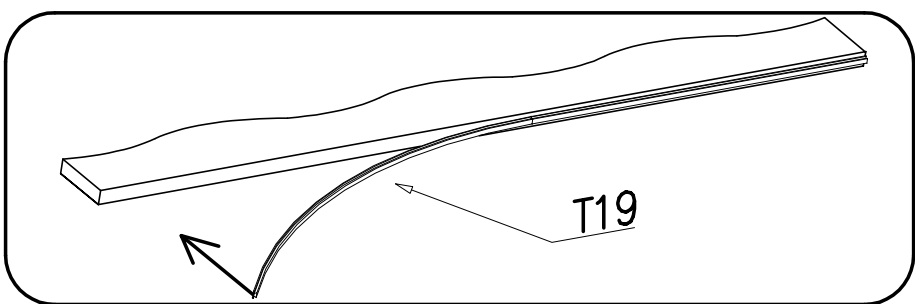
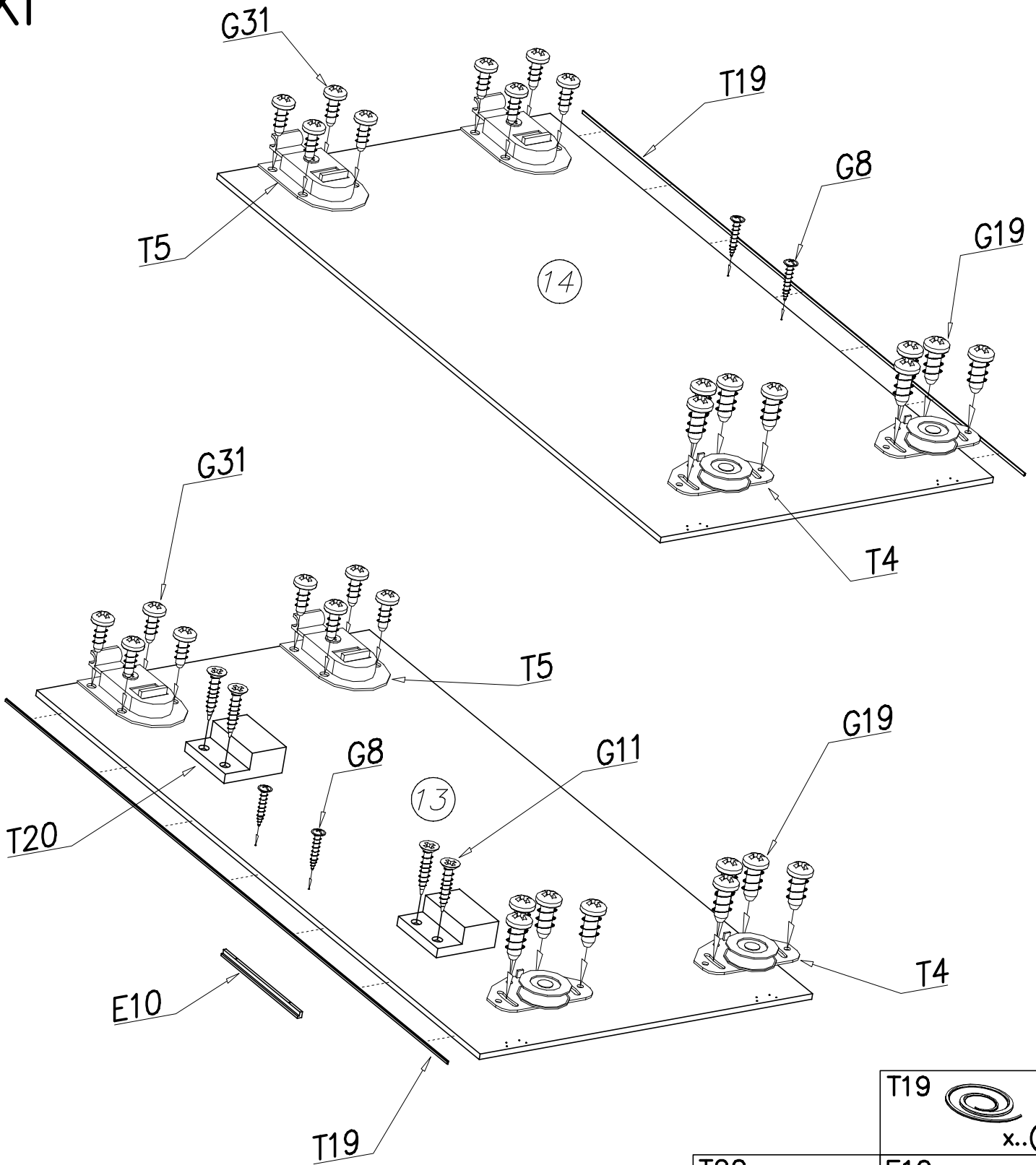

X

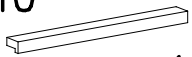
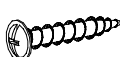

S5	F1
	
x...(2)	x...(24)

XI

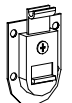

T20	 x...(2)	T19	 x...(2)
G11	 4x20 x...(4)	E10	 x...(2)
G8	 4x30 x...(4)	G19	 6x13 x...(16)
G31	 4x13 x...(16)	T5	 x...(4)
		T4	 x...(4)

XII

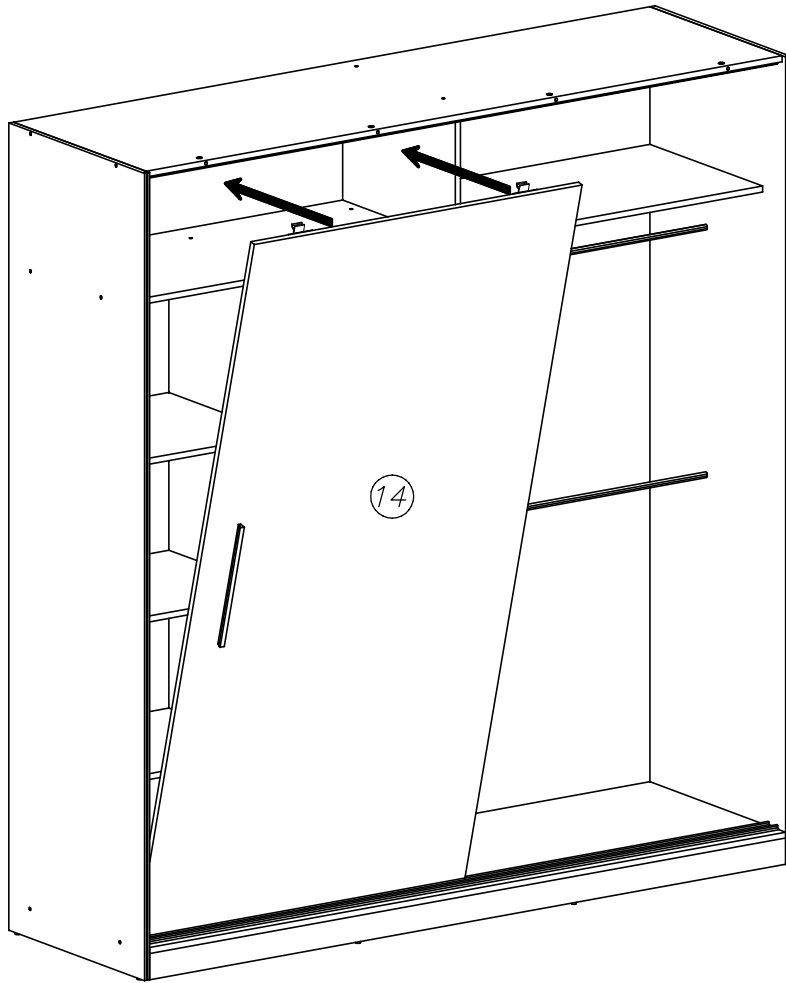

1



2

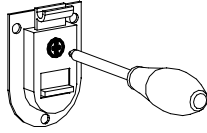

3



4

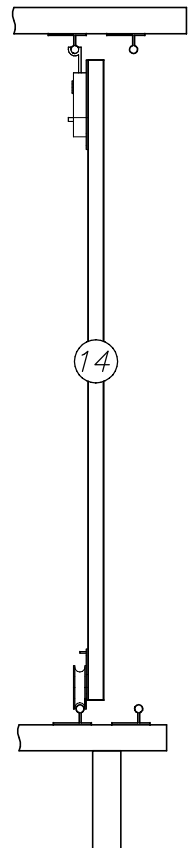
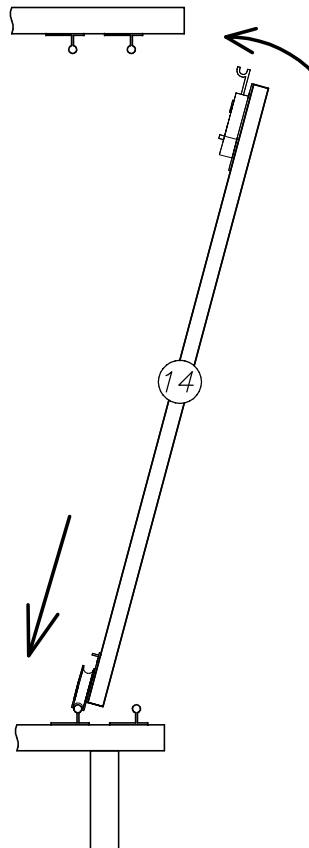
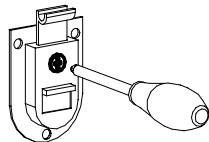

XIII

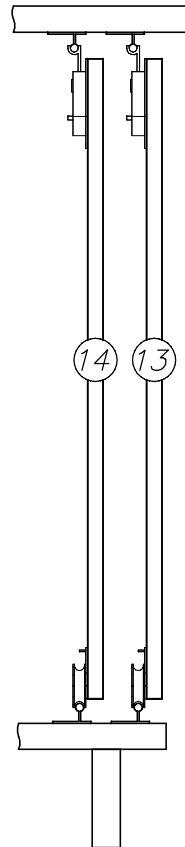
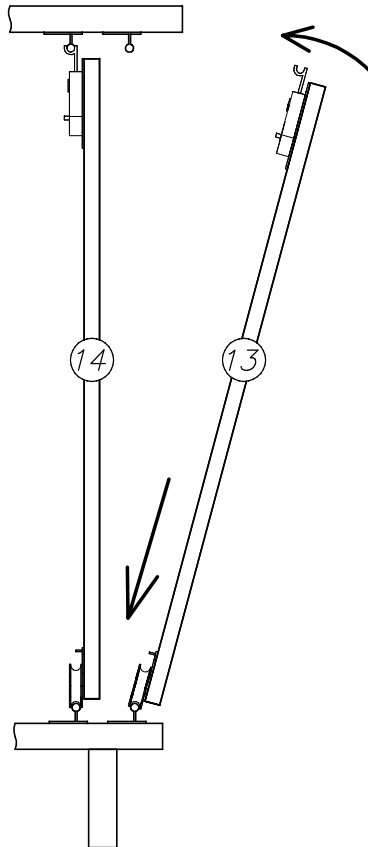
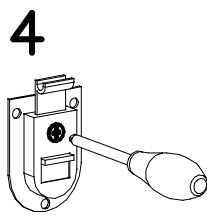
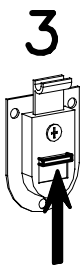
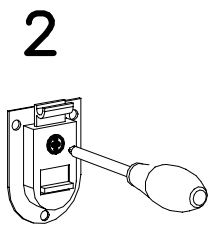
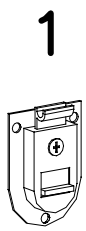
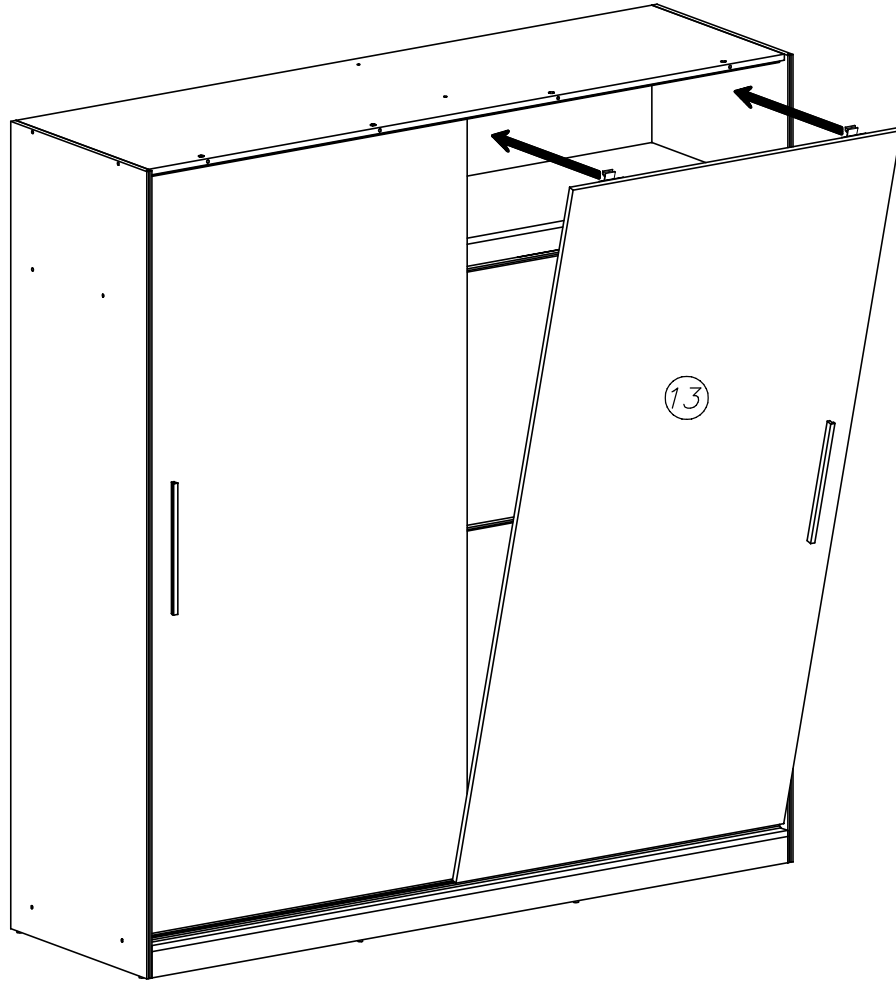

XIV

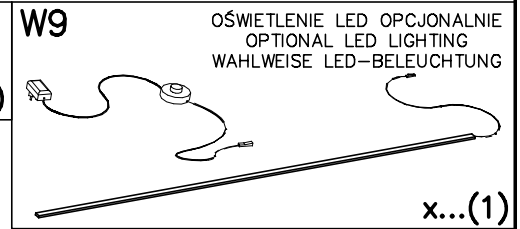
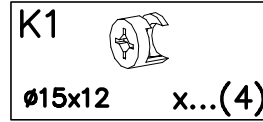
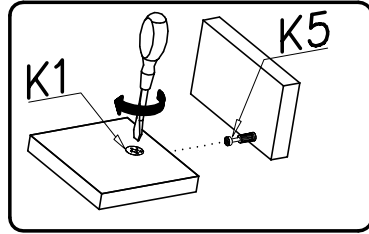
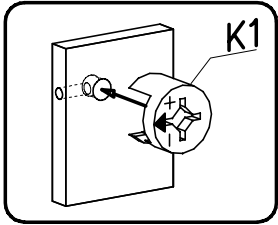
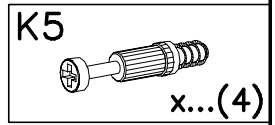
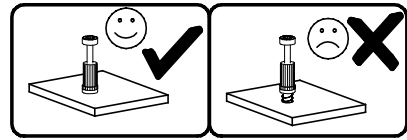
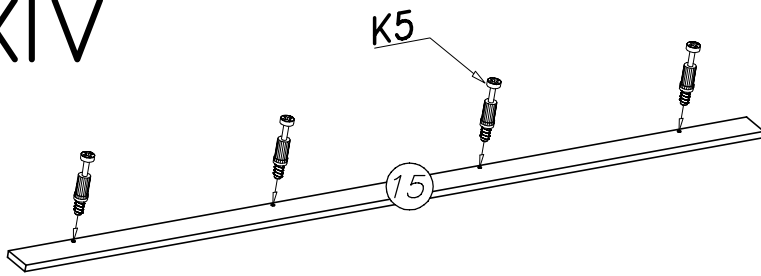

XV

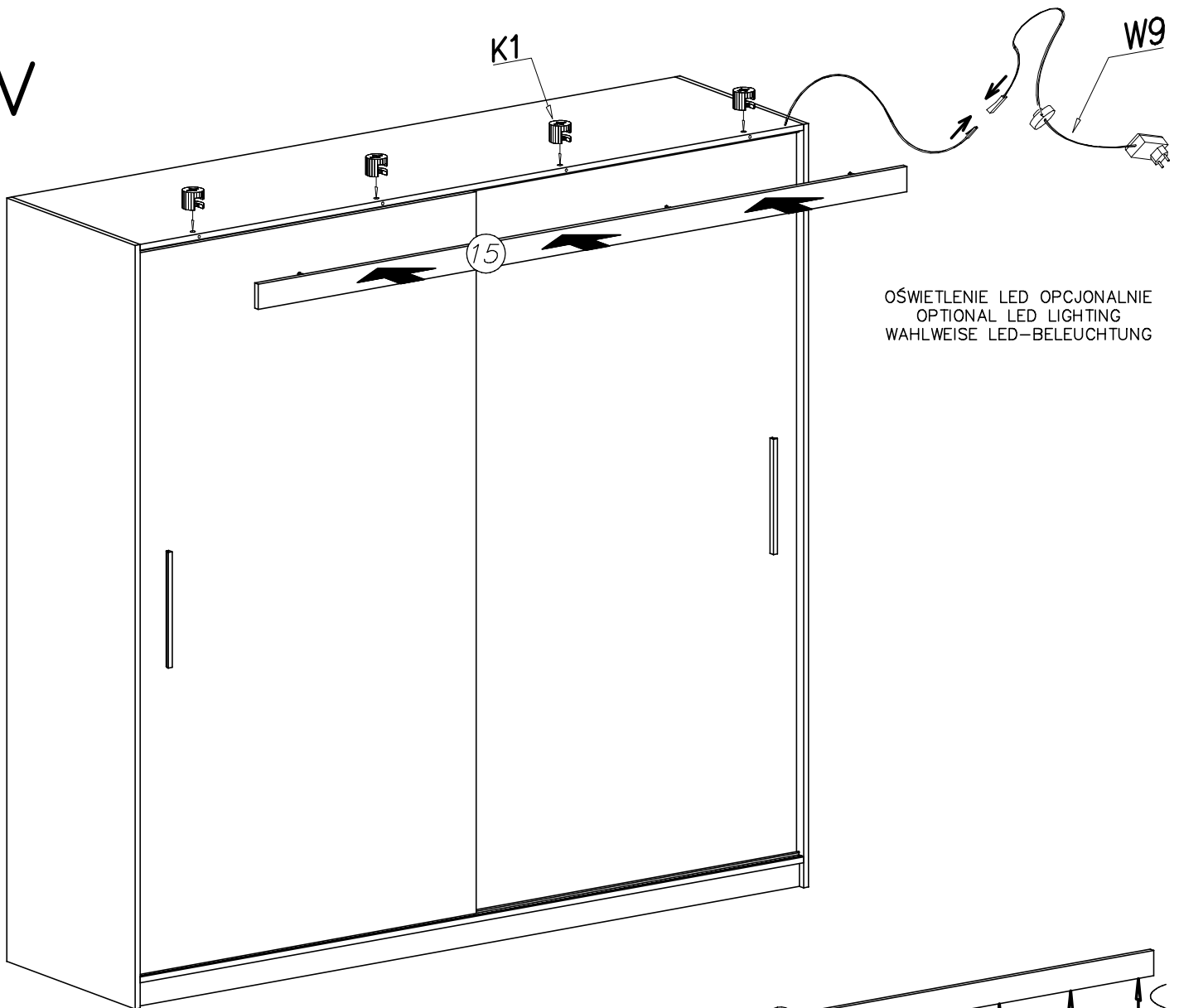

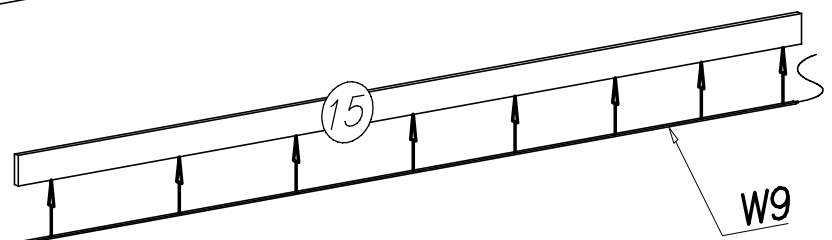

OŚWIETLENIE LED OPCJONALNIE
OPTIONAL LED LIGHTING
WAHLWEISE LED-BELEUCHTUNG

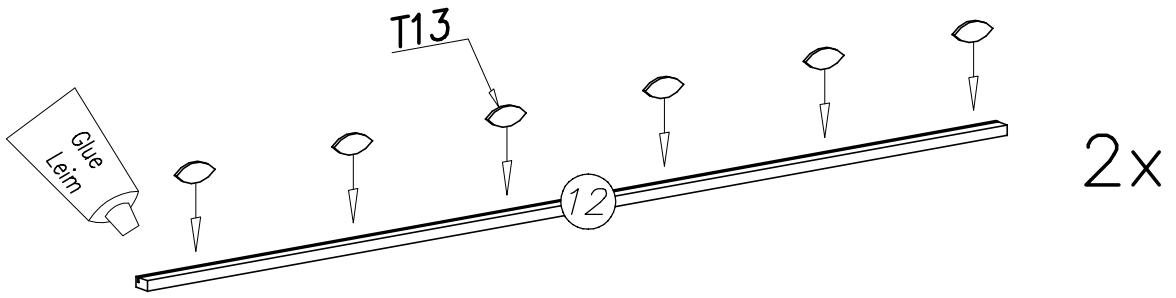

OŚWIETLENIE LED OPCJONALNIE
OPTIONAL LED LIGHTING
WAHLWEISE LED-BELEUCHTUNG

XVI



T13		x...(12)
W1		x...(1)

XVII

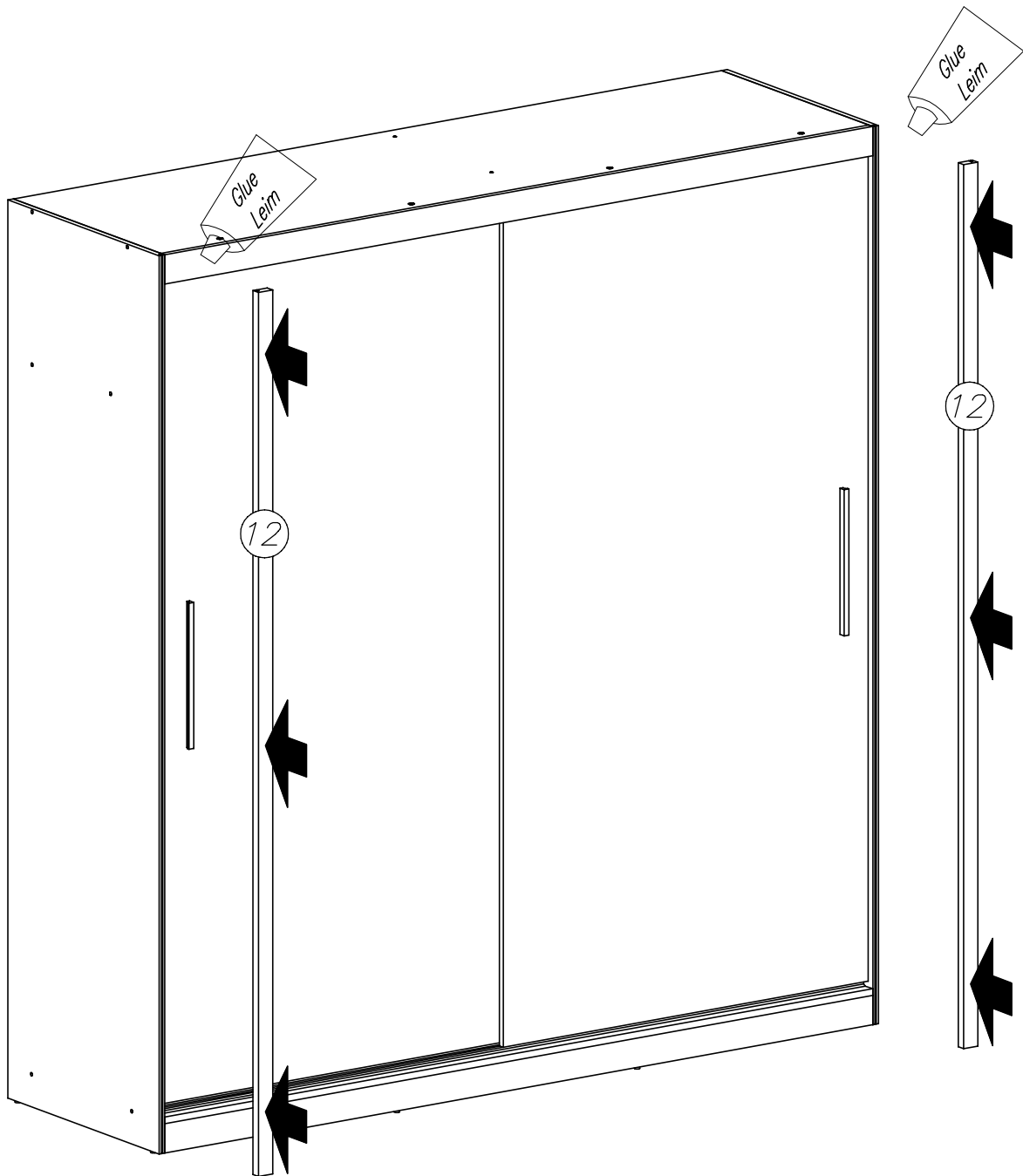

W1		x...(1)
----	---	---------