

0398E3PT

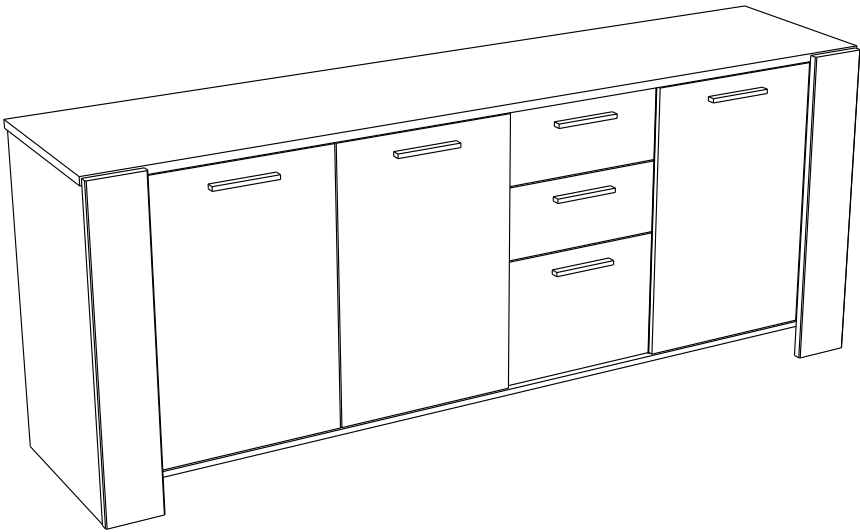

Gamme : TRAVIS



PARISOT INDUSTRIE

FR Remerciements :

Nous vous remercions d'avoir choisi un meuble créé et fabriqué par le Groupe Parisot et espérons qu'il vous donnera entière satisfaction.

EN Thanks:

Thank you for choosing furniture designed and manufactured by the Parisot Group. We hope you are totally satisfied with your purchase.

DE Danksagung:

Wir danken Ihnen für den Kauf eines Frankreich von der Parisot-Gruppe entworfenen und hergestellten Möbelstücks und hoffen, dass Sie es zu Ihrer vollkommenen Zufriedenheit finden werden.

HU Köszönet:

Köszönjük, hogy a Parisot Groupe által létrehozott és gyártott bútort választott, reméljük, hogy elégedett lesz a termékkel.

PT Agradecimentos:

Obrigado por ter escolhido um móvel concebido e fabricado pelo Grupo Parisot, esperando que seja do seu inteiro agrado.

IT Ringraziamenti:

Grazie per avere scelto un mobile progettato e fabbricato dal Gruppo Parisot. Speriamo soddisfi appieno le vostre esigenze.

NL Bedankje:

Wij bedanken u voor de aankoop van een door de Groep Parisot ontworpen en vervaardigd meubel en hopen dat u er veel plezier aan zult beleven.

CZ Poděkování:

Děkujeme, že jste si vybrali nábytek navržený a vyrobený společností Parisot Group. Doufáme, že budete svým nákupem naprosto spokojeni.

ES Agradecimientos:

Les damos las gracias por haber elegido un mueble diseñado y fabricado por el Groupe Parisot y esperamos que sea de su total agrado.

PL Podziękowania:

Dziękujemy za wybór mebli stworzonych i wyprodukowanych przez Grupę Parisot. Mamy nadzieję, że będziecie Państwo w pełni zadowoleni z zakupu.

SK Poďakovanie:

Ďakujeme, že ste si vybrali nábytok navrhnutý a vyrobený spoločnosťou Parisot Group. Dúfame, že budete svojim nákupom absolútne spokojní.

AR شكر:

نشكركم لاختياركم هذه القطعة من الأثاث من تصميم وتصنيع مجموعة باريسو Parisot ونتمنى أن تنال رضاءكم.

PARISOT INDUSTRIE

15 Avenue Jacques Parisot, 70800 Saint-Loup sur Semouse
contact@parisot.com
RCS VESOUL 537 665 200

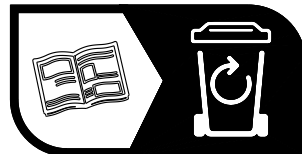
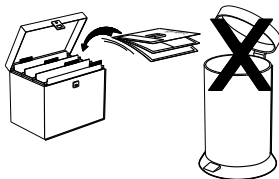

FR

Donnez ou recyclez
vos meubles.



Association



Magasin



Déchèterie

<https://quefairedemesdechets.fr>

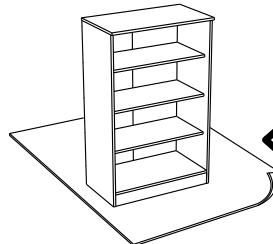
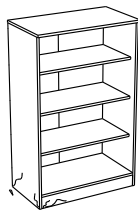
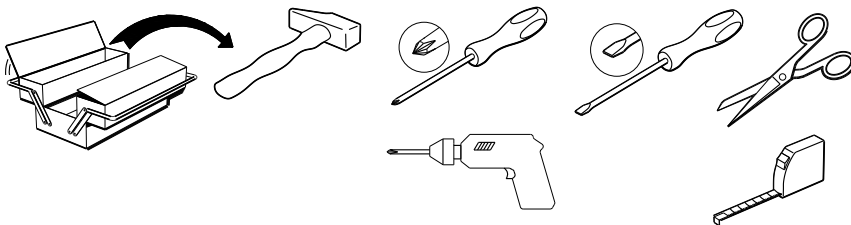

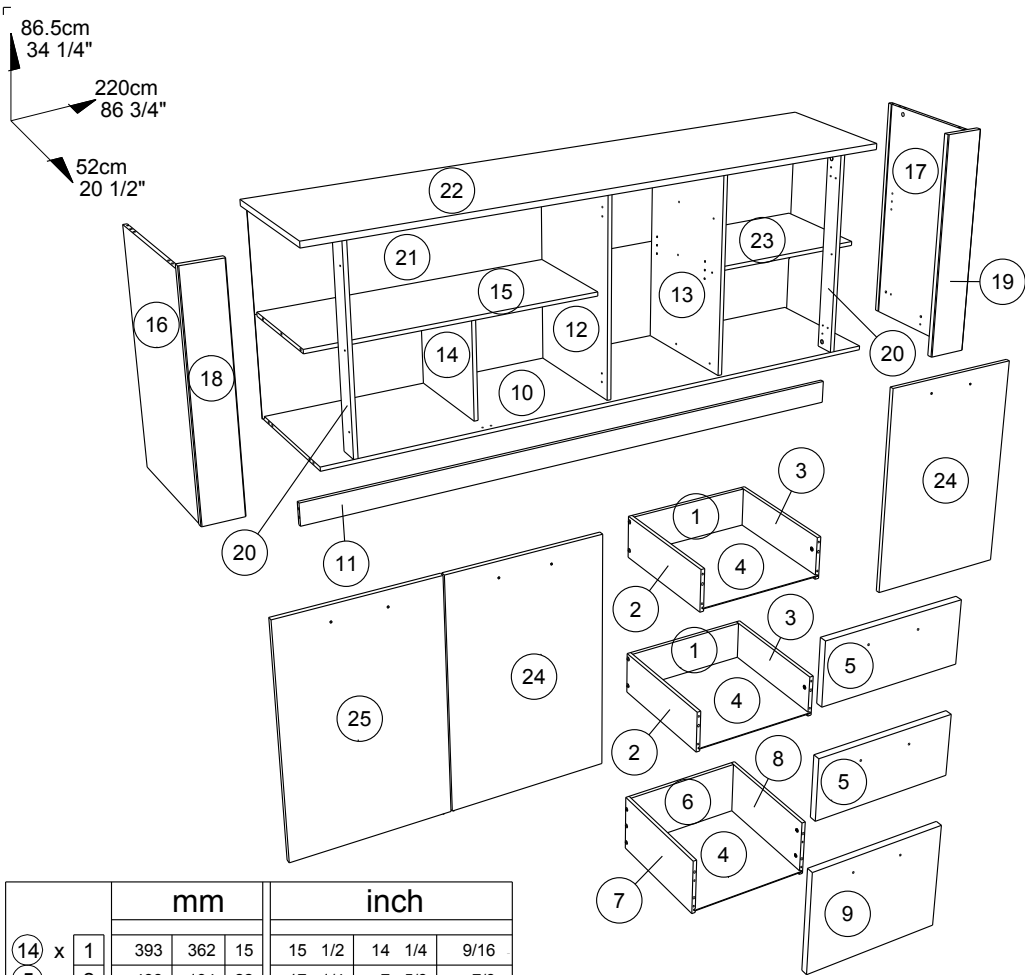





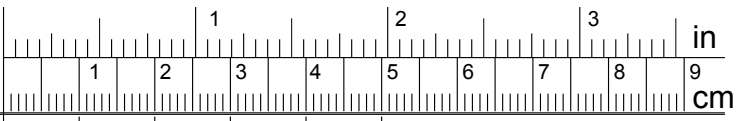

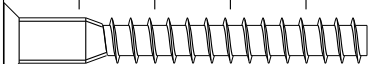
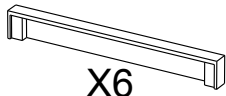

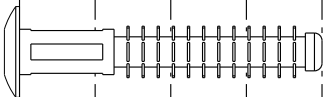







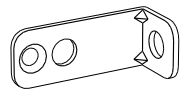
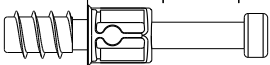
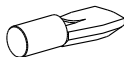
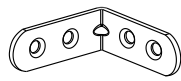

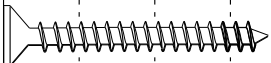
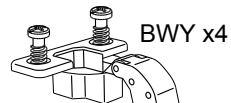

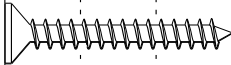
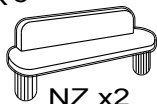

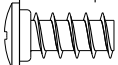
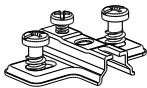

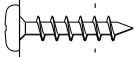
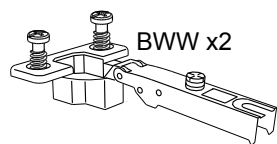

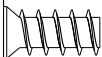
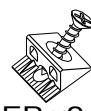

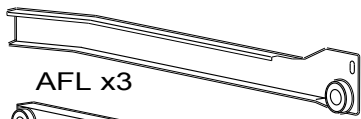
		mm			inch		
(14)	x 1	393	362	15	15 1/2	14 1/4	9/16
(5)	x 2	438	194	22	17 1/4	7 5/8	7/8
(9)	x 1	438	339	22	17 1/4	13 3/8	7/8
(23)	x 1	599	395	15	23 9/16	15 9/16	9/16
(24)	x 2	735	479	15	28 15/16	18 7/8	9/16
(25)	x 1	735	479	15	28 15/16	18 7/8	9/16
(20)	x 2	741	76	16	29 3/16	3	5/8
(13)	x 1	741	461	15	29 3/16	18 1/8	9/16
(12)	x 1	741	461	15	29 3/16	18 1/8	9/16
(17)	x 1	843	498	15	33 3/16	19 5/8	9/16
(16)	x 1	843	498	15	33 3/16	19 5/8	9/16
(19)	x 1	860	150	22	33 7/8	5 7/8	7/8
(18)	x 1	860	150	22	33 7/8	5 7/8	7/8
(15)	x 1	1081	395	15	42 9/16	15 9/16	9/16
(11)	x 1	2154	86	15	84 13/16	3 3/8	9/16
(10)	x 1	2154	498	15	84 13/16	19 5/8	9/16
(22)	x 1	2198	498	22	86 9/16	19 5/8	7/8

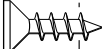
		mm			inch		
(3)	x 2	400	138	13	15 3/4	5 7/16	1/2
(2)	x 2	400	138	13	15 3/4	5 7/16	1/2
(8)	x 1	400	196	13	15 3/4	7 11/16	1/2
(7)	x 1	400	196	13	15 3/4	7 11/16	1/2
(1)	x 2	394	138	13	15 1/2	5 7/16	1/2
(6)	x 1	394	196	13	15 1/2	7 11/16	1/2
(4)	x 3	406	399	3	16	15 11/16	1/8
(21)	x 1	2170	755	3	85 7/16	29 3/4	1/8

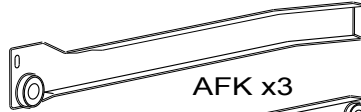

		HW x6		X6
		CQA x14		BZG x8
		ADM x31		HV x 1
		ADU x12		Ai x27
				BLL x 10
		BSD x35		BWD x4
				LN x 3
		VAF12 x6		BWY x4
		WF x 6		NZ x2
		VB x16		BWU x6
		QA x 18		BWW x2
		BWF x 12		EP x2
		ANK x6		AFL x3
		VG x20		AFN x3
				AFK x3
				AFM x3

1

ADU x8

BSD x 4

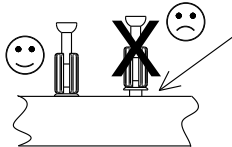
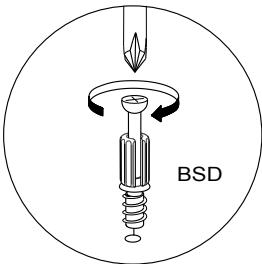
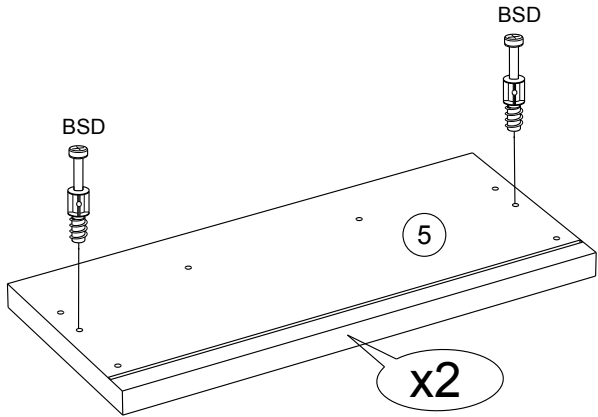
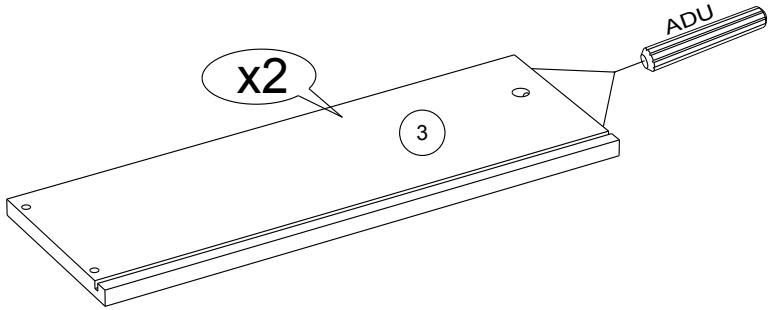
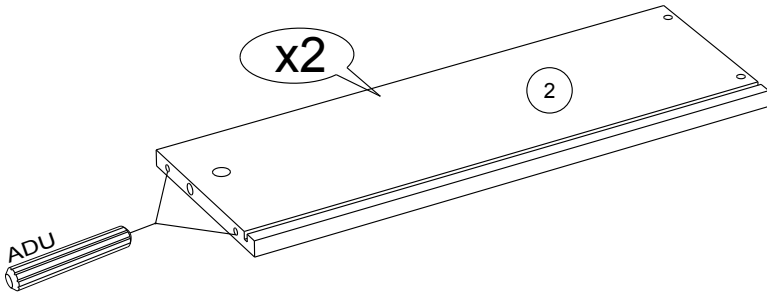

2

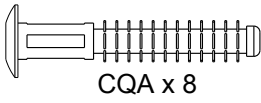

BZG x 4

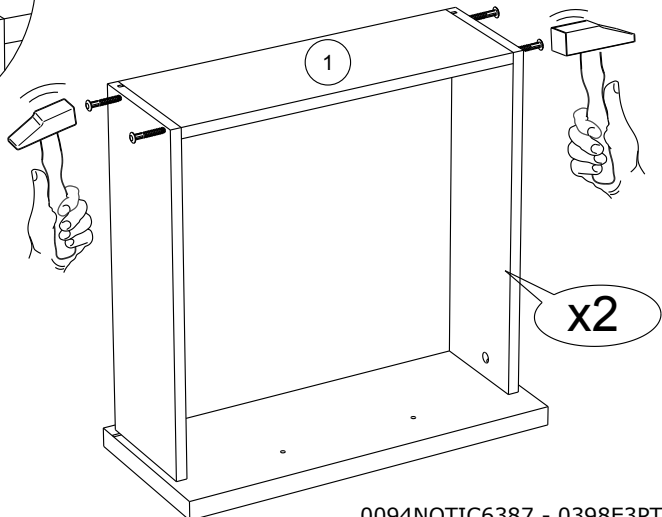
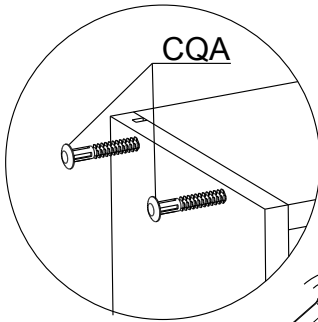
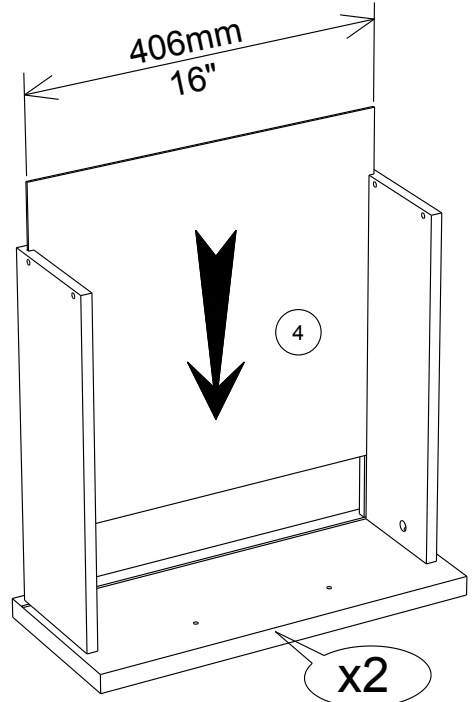
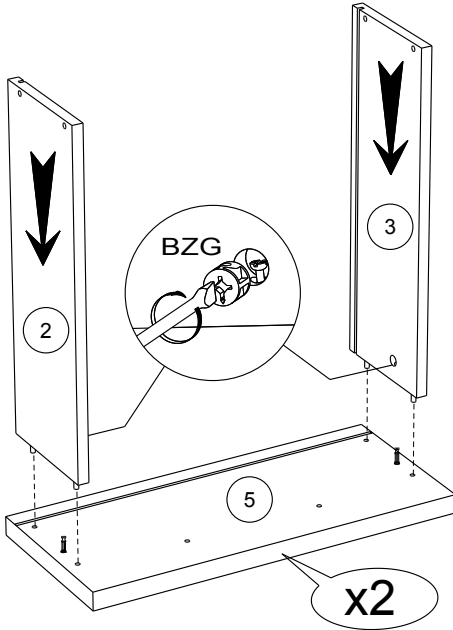

3

ADU x4

BSD x 4

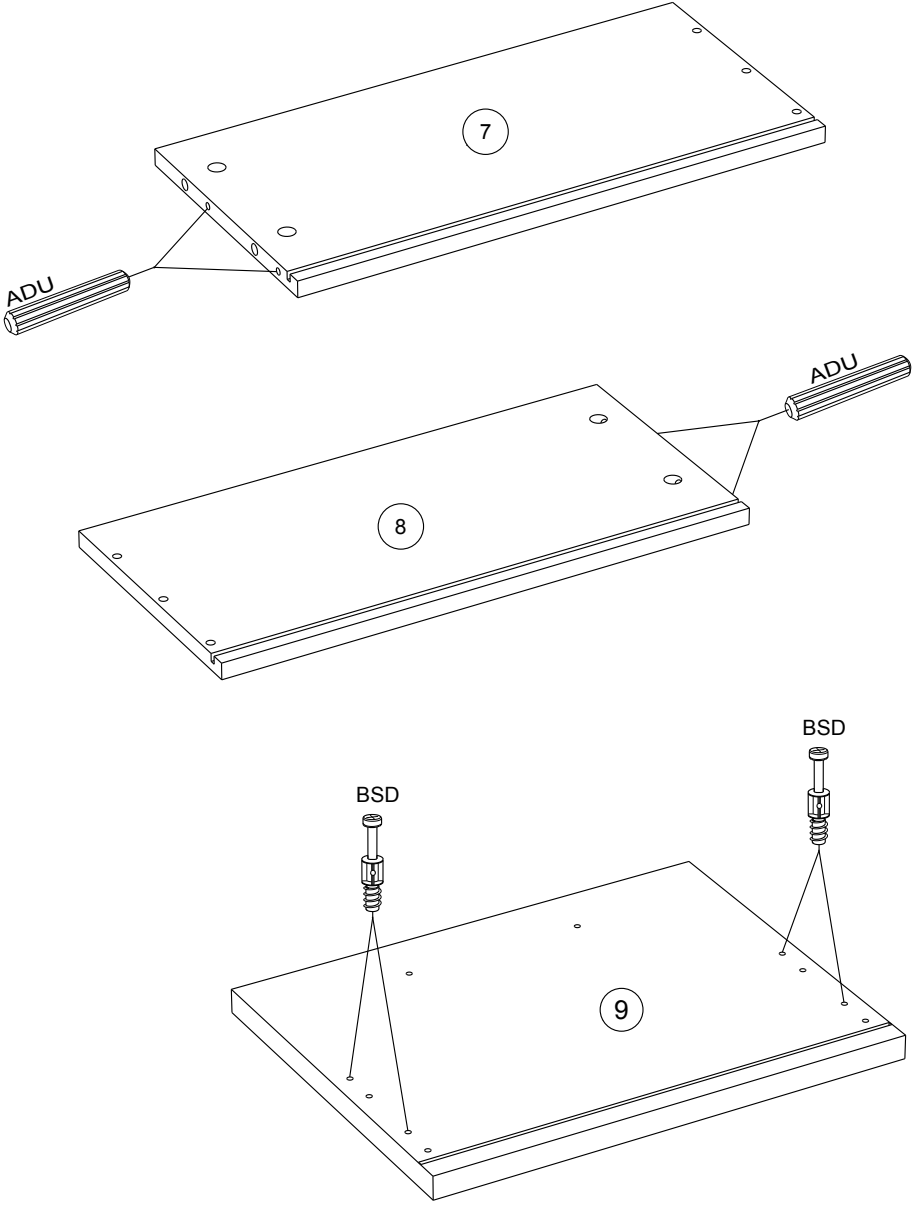

4



CQA x 6



BZG x 4

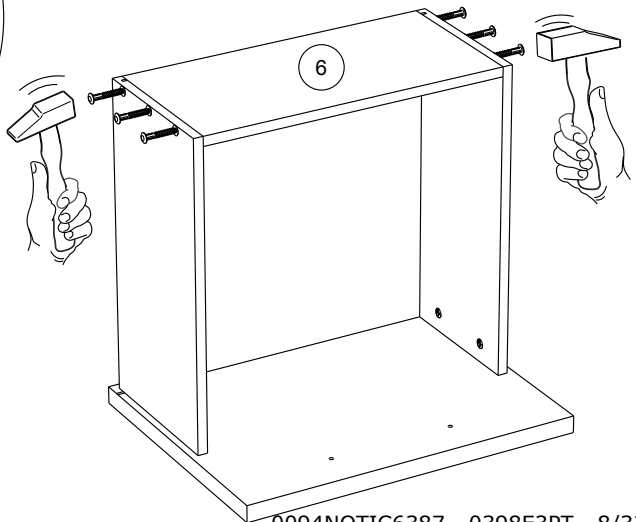
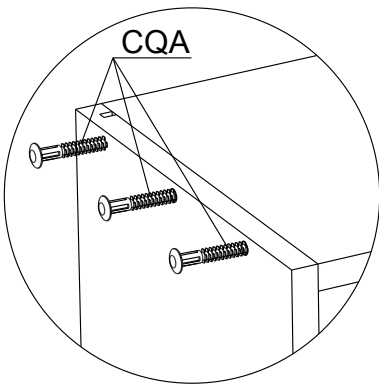
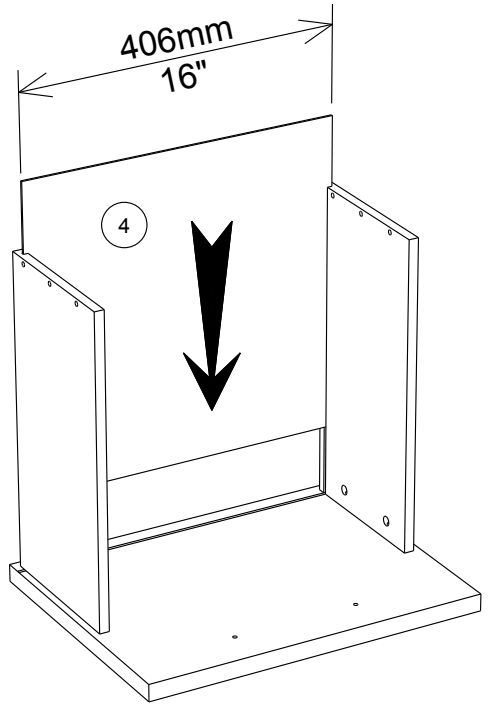
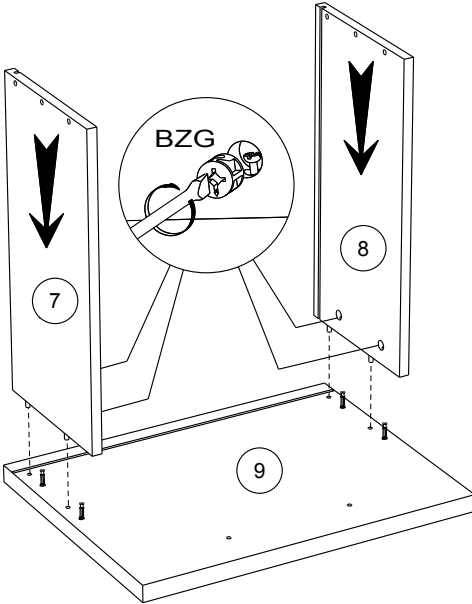

5

ADM x 4

BSD x 2

ANK x 3

NZ x 1

ANK

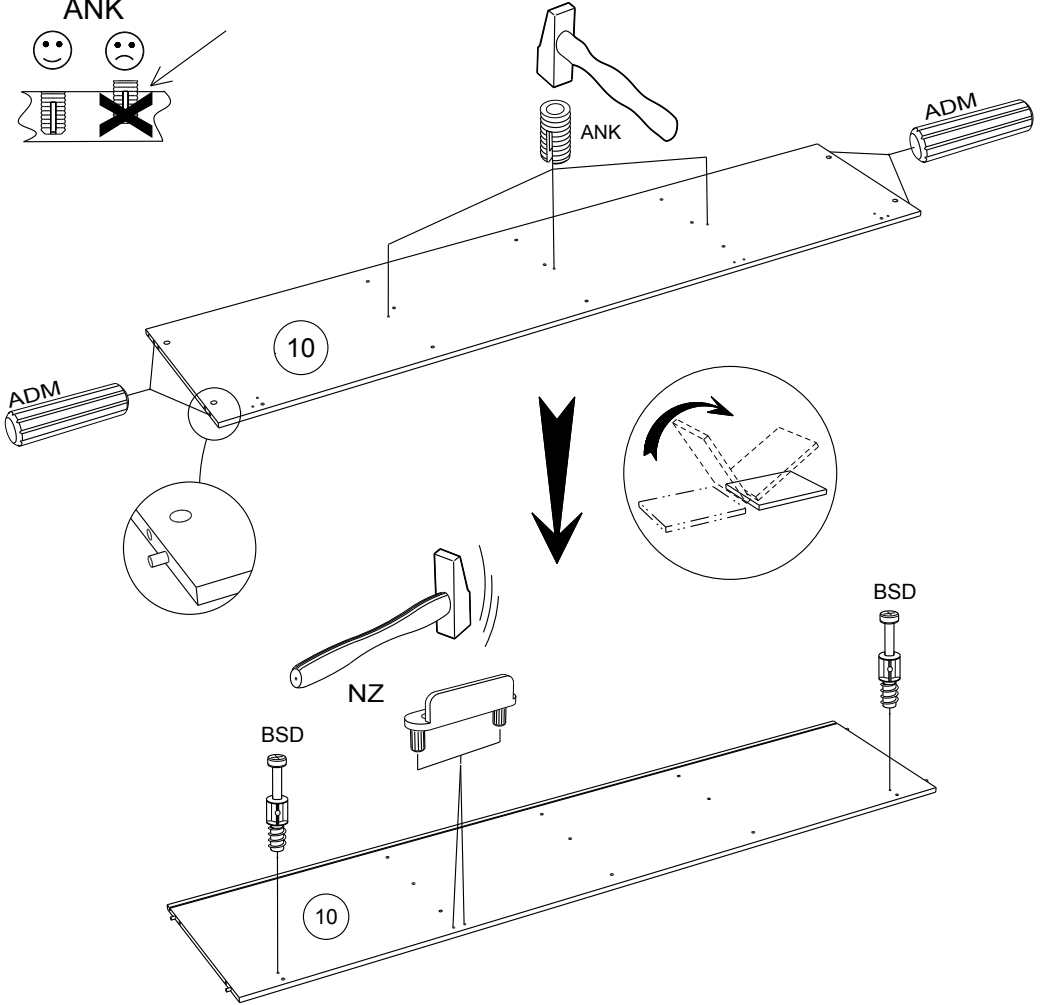
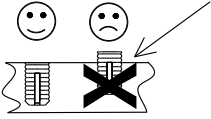

6

ADM x 3

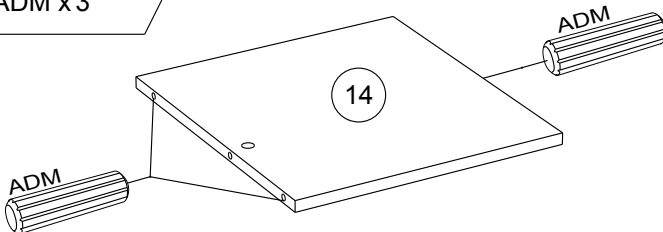

7

ANK x 3

ADM x 2

LN x 3

VG x 6

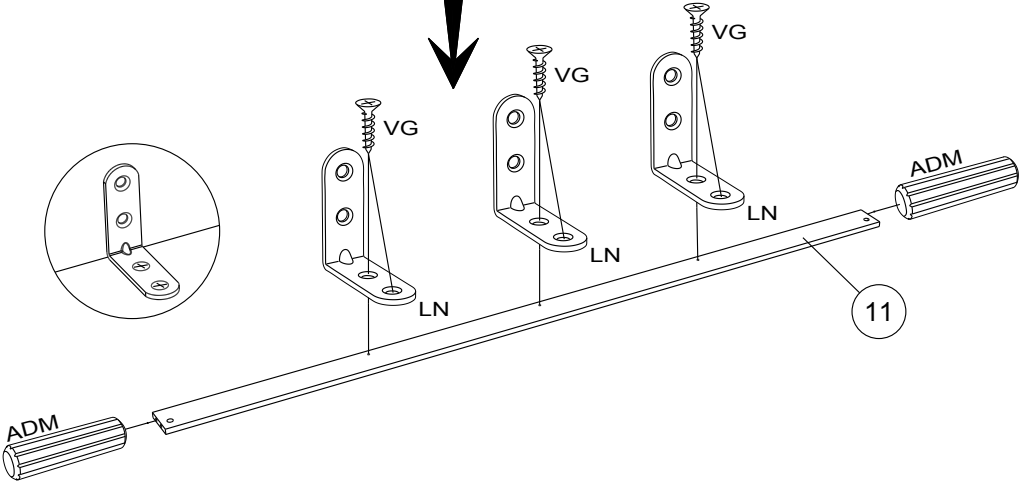
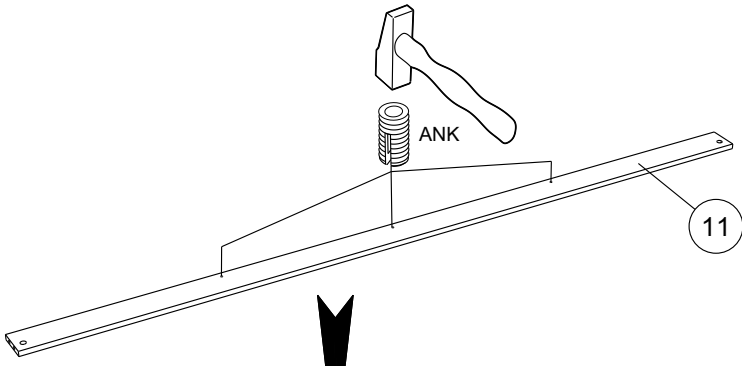

8

ADM x 4

BSD x 1

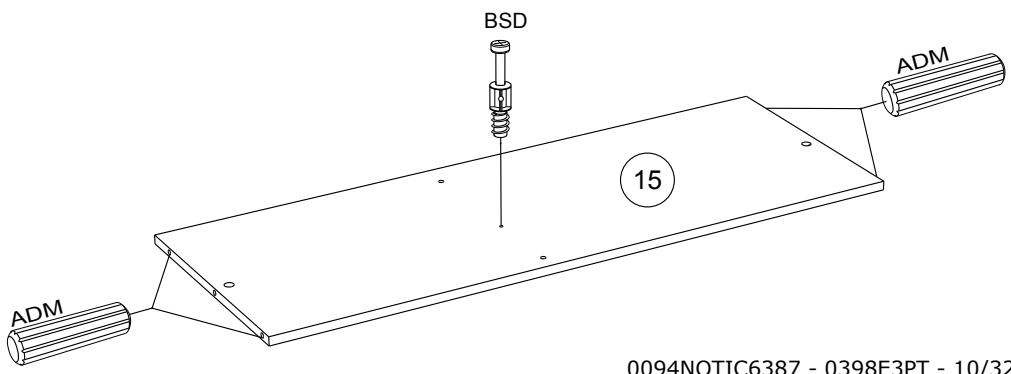

9

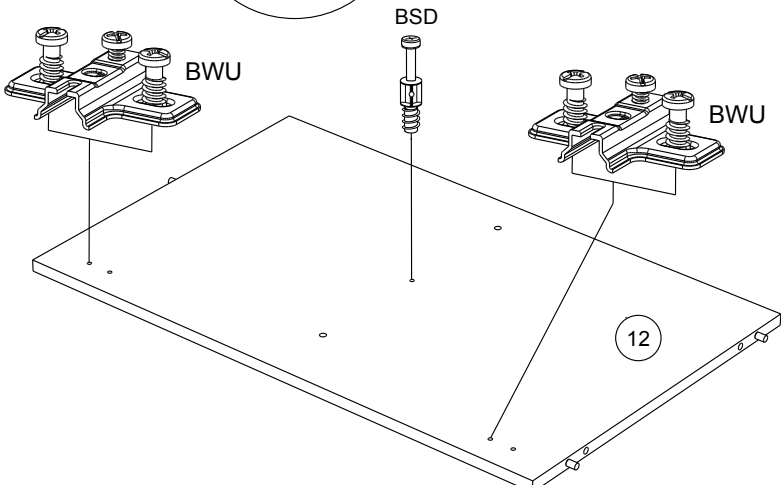
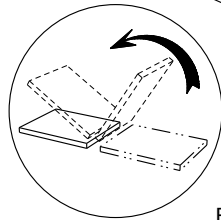
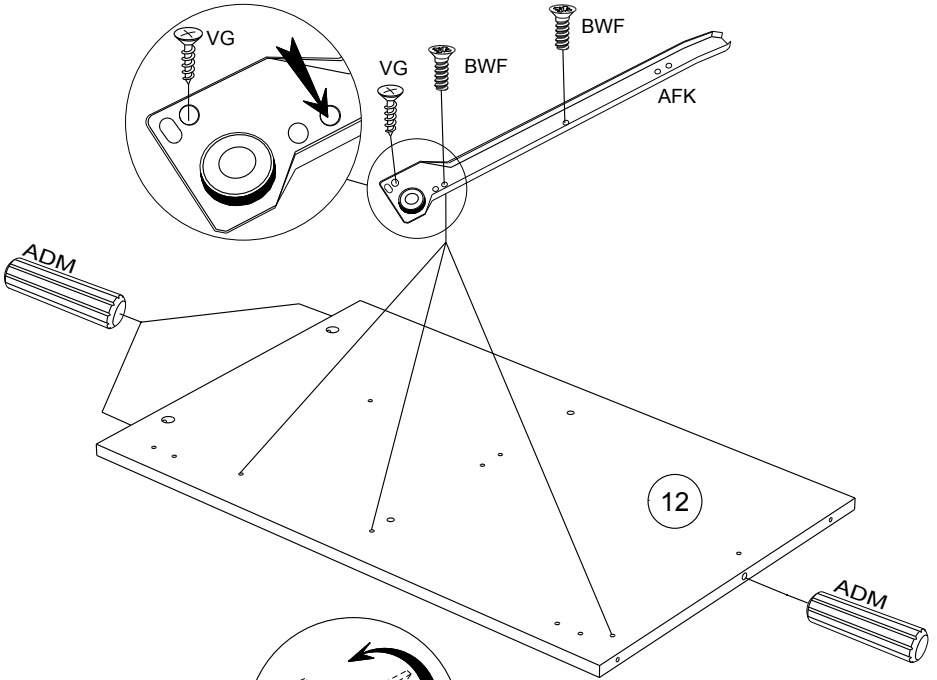
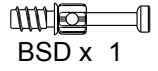
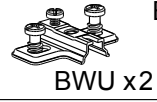

10

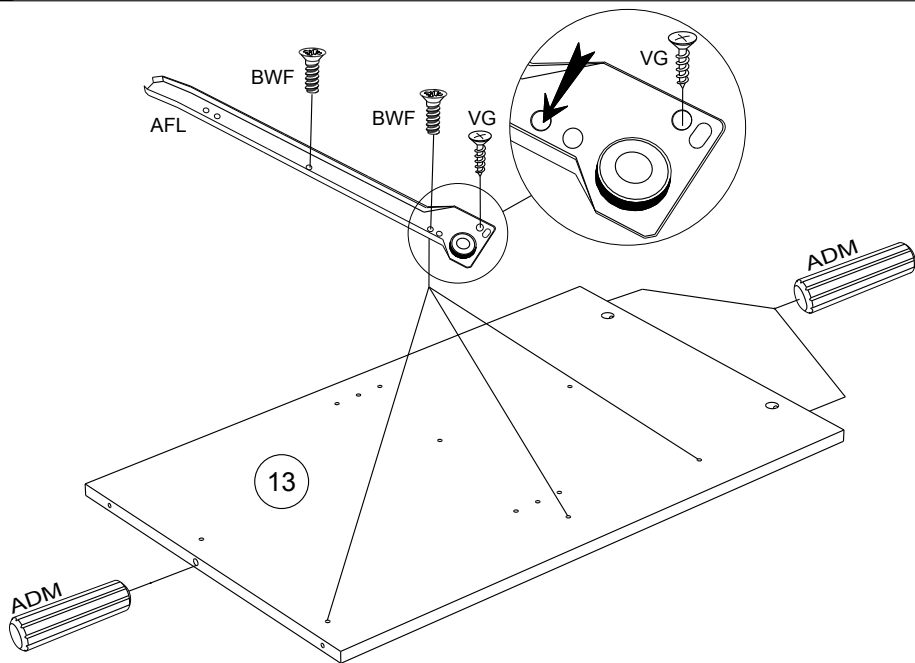
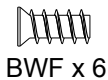
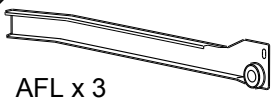

11



Ai x 2

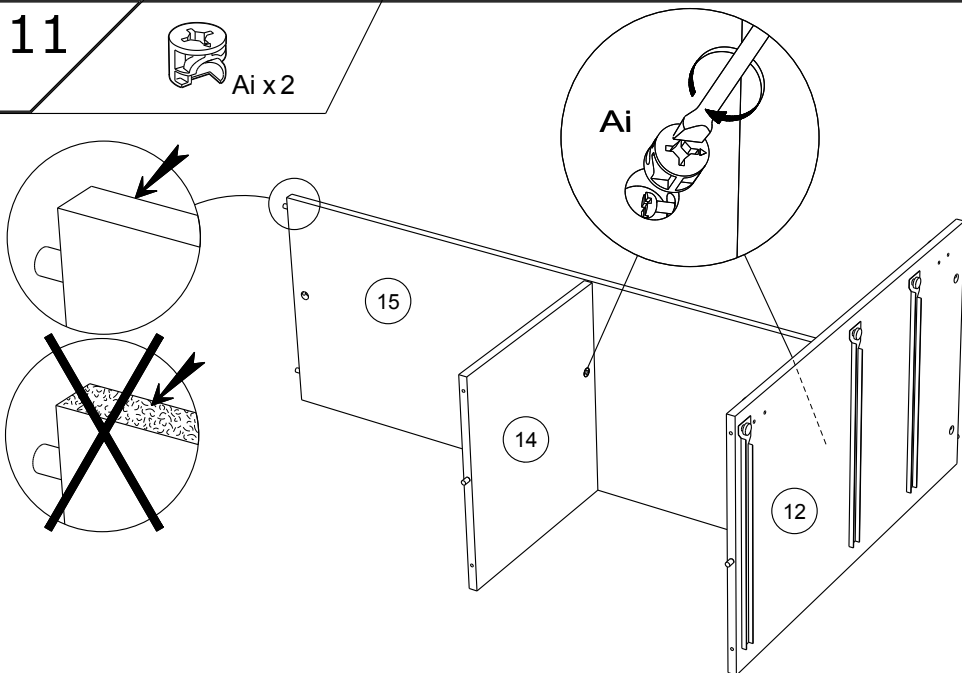

12

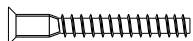

HW x 6



HV x 1

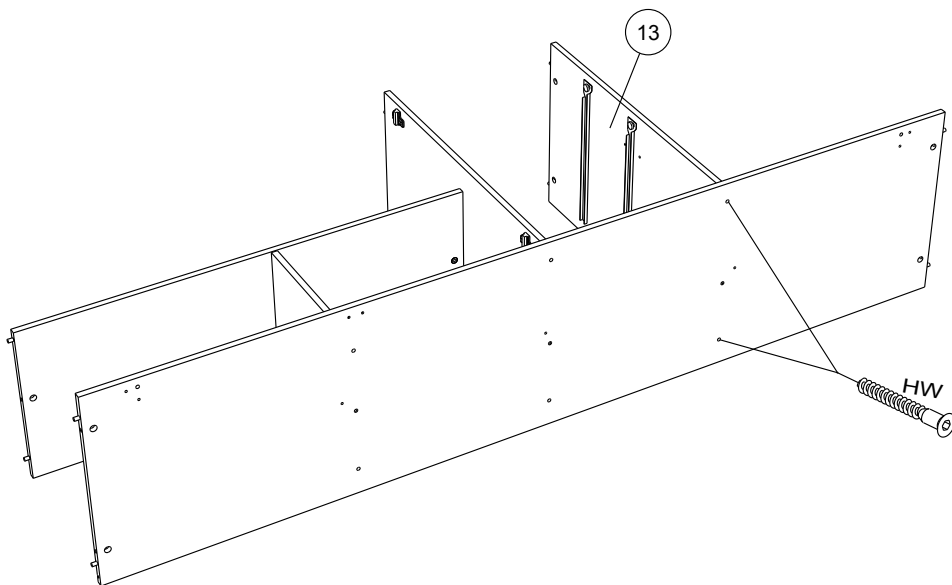
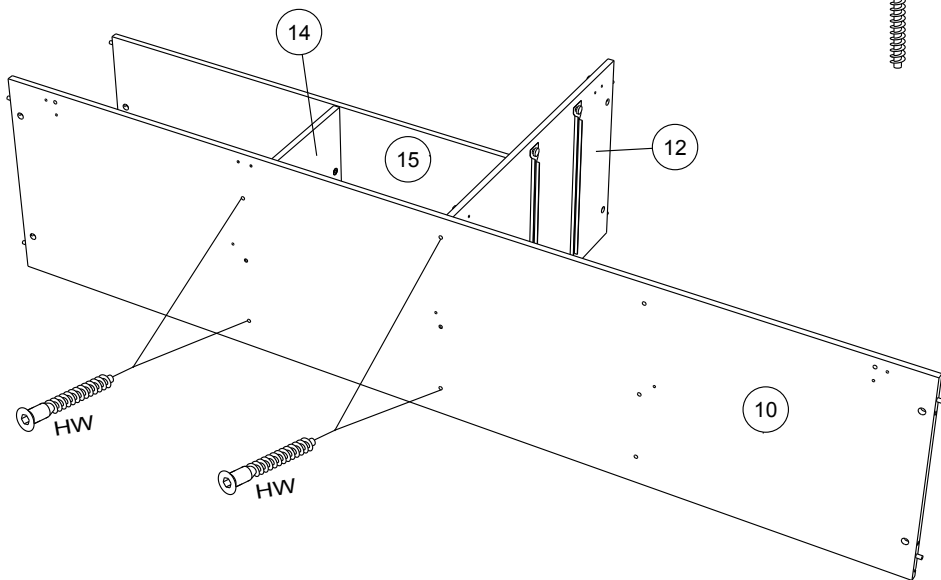
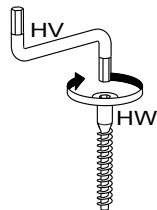

13

ADM x4

VB x 1

BLL x1

BSD x 7

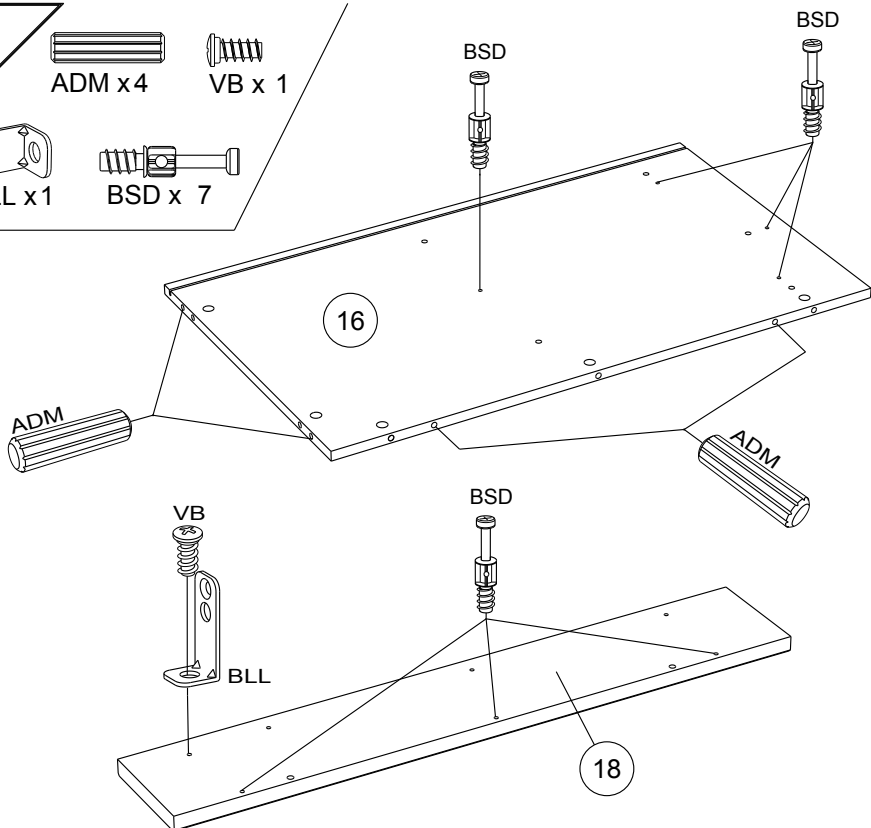

14

Ai x3

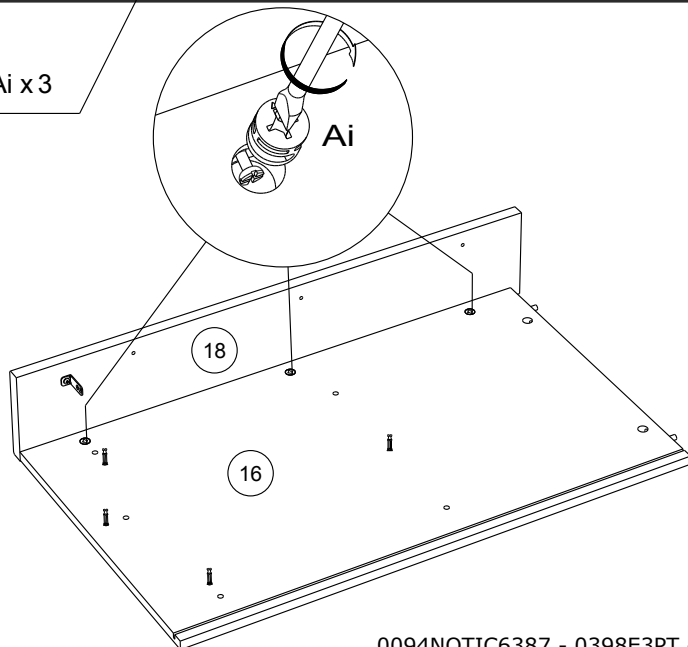

15



ADM x 4



VB x 1

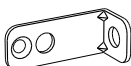

BLL x 1



BSD x 6

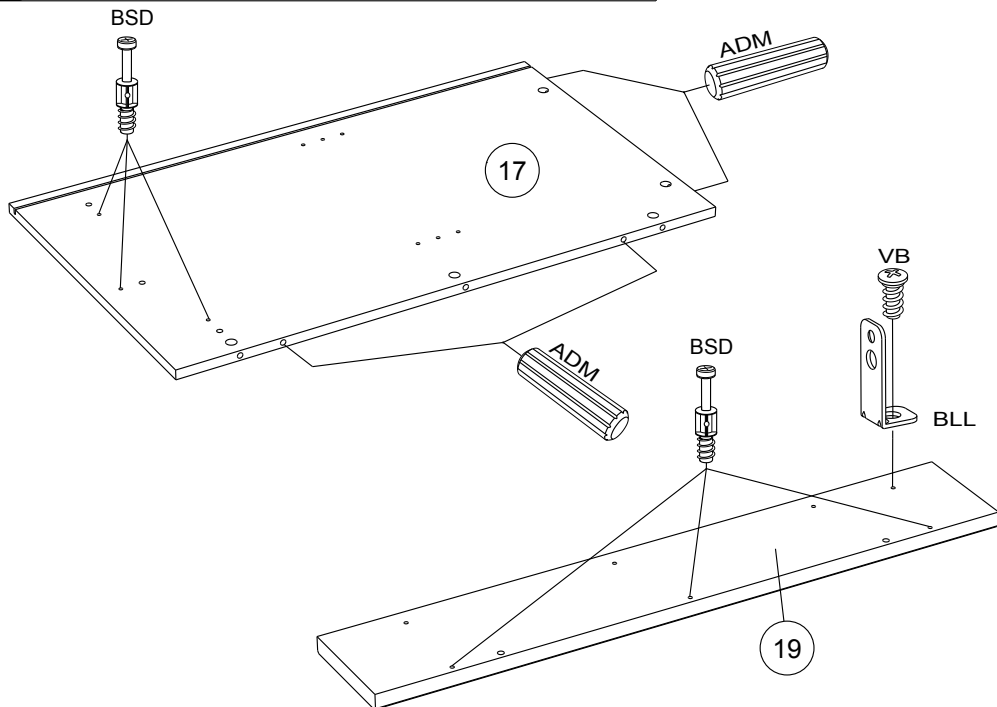

16



Ai x 3

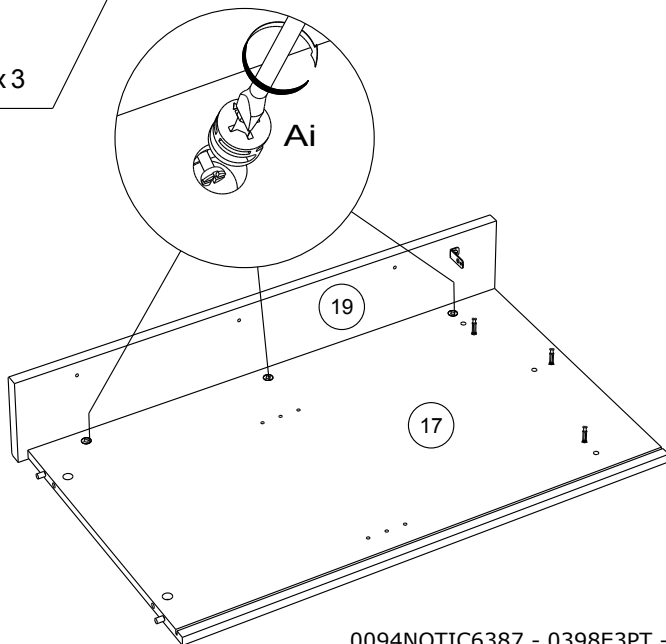

17



Ai x3

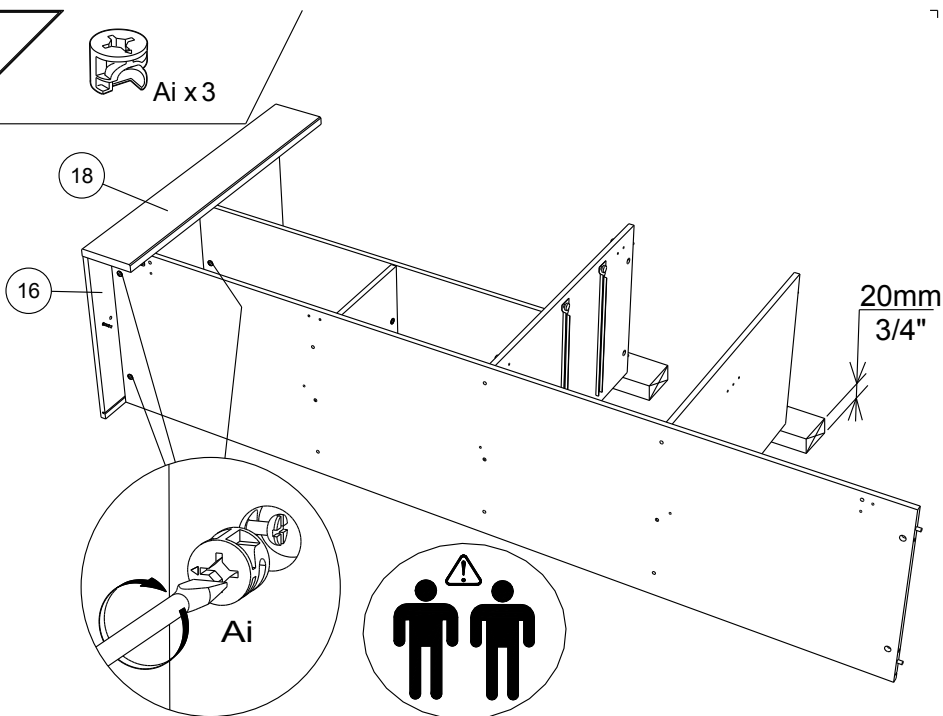

18



Ai x1



VG x6

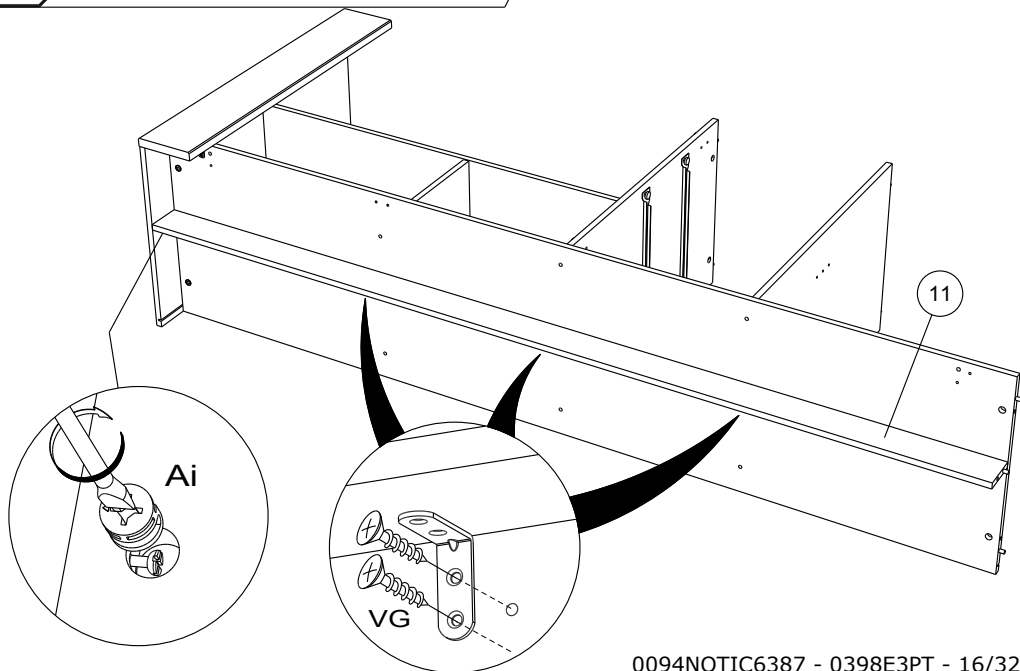

19



Ai x 3

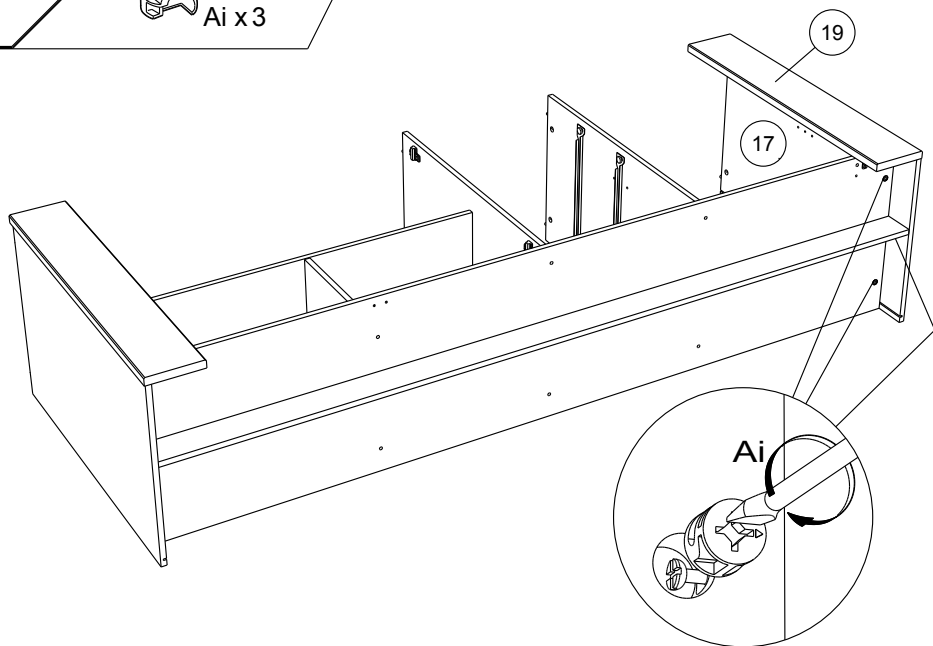

20



VB x 2

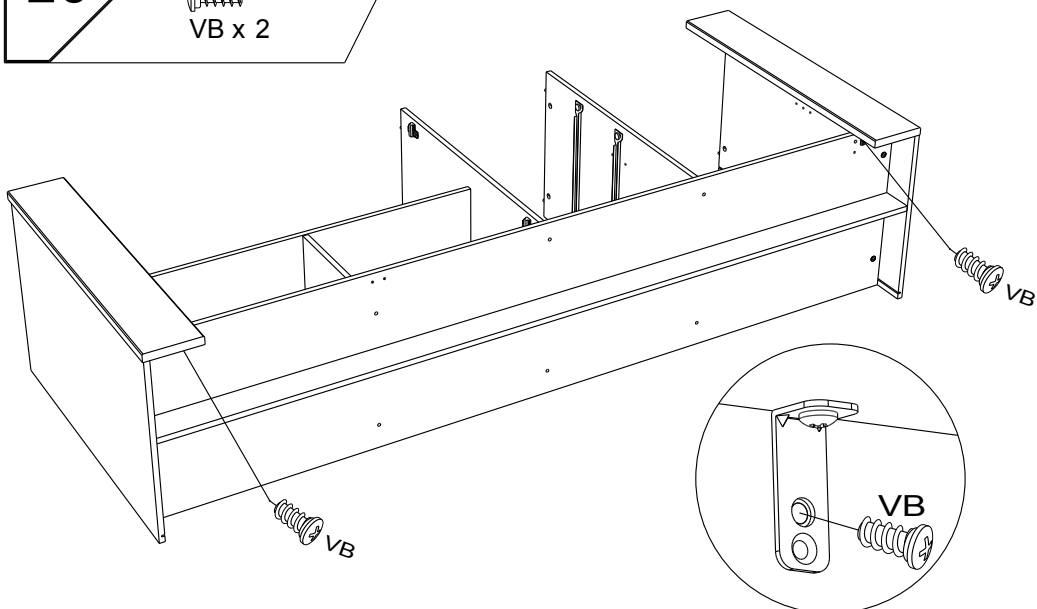

21

ADM x4

BWU x4

BLL x6

VB x6

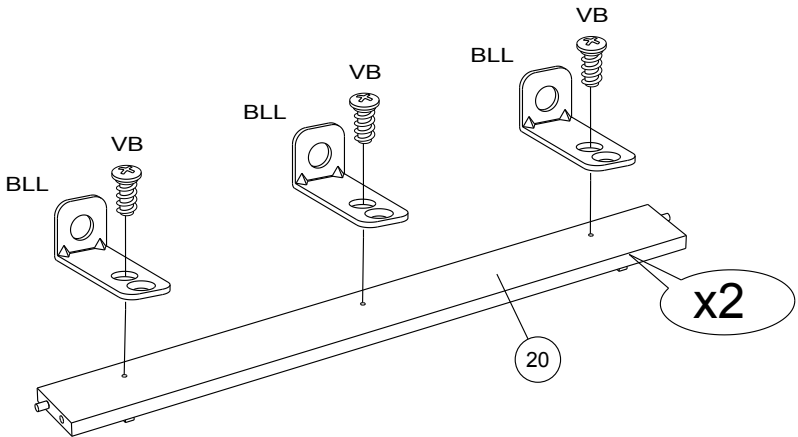
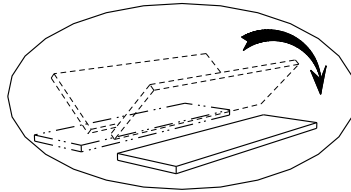
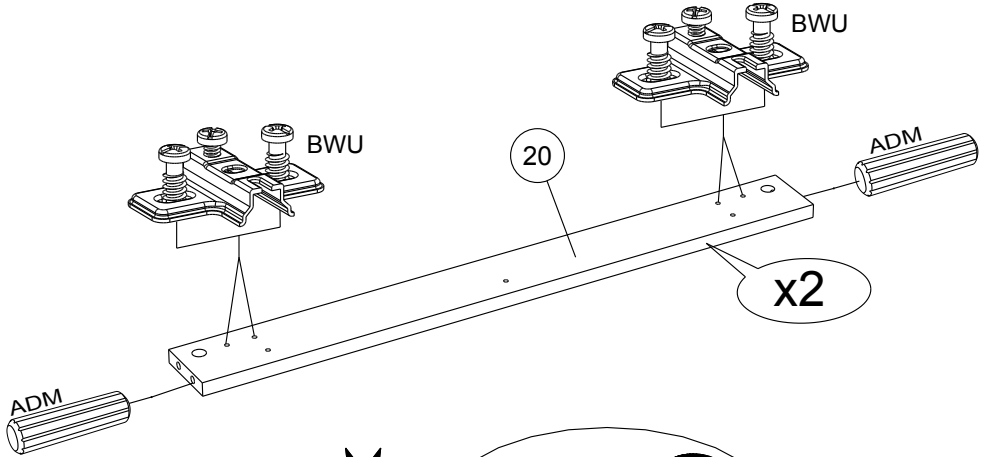

22

BSD x 10

NZ x 1

BLL x 2

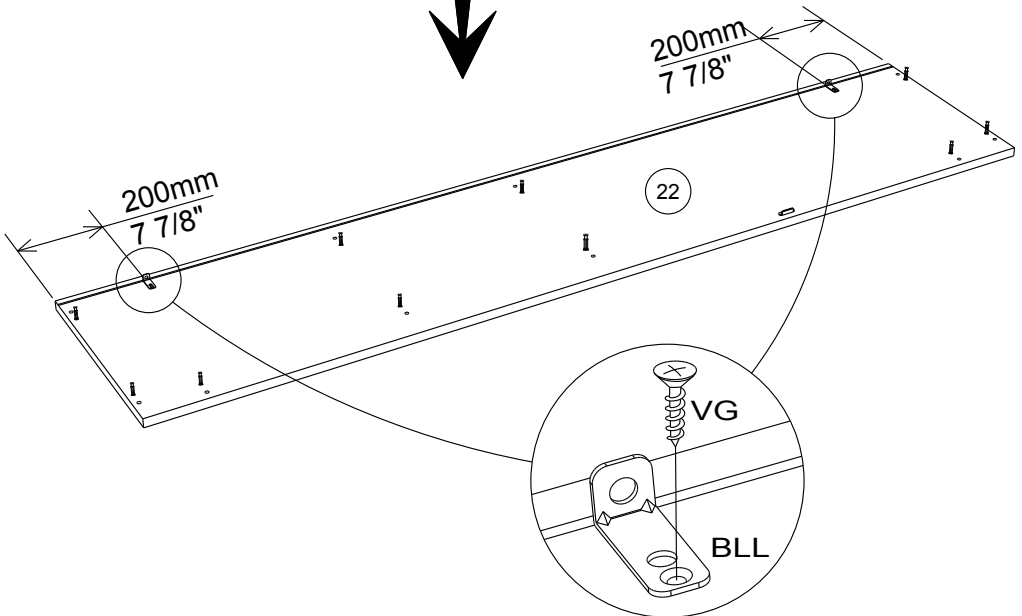
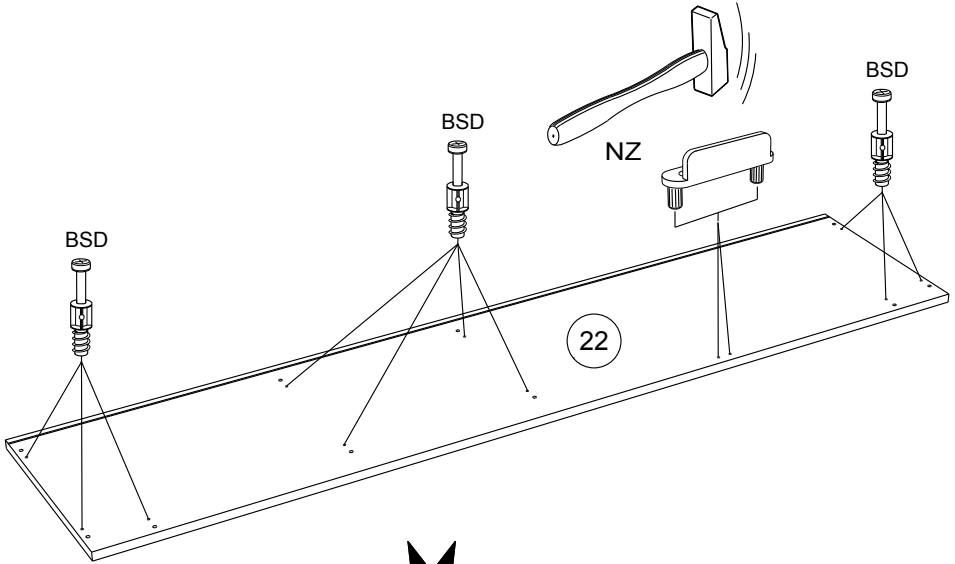

VG x 2



23

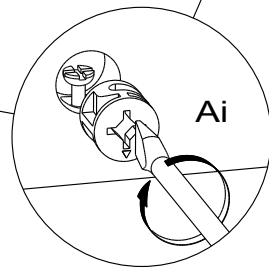
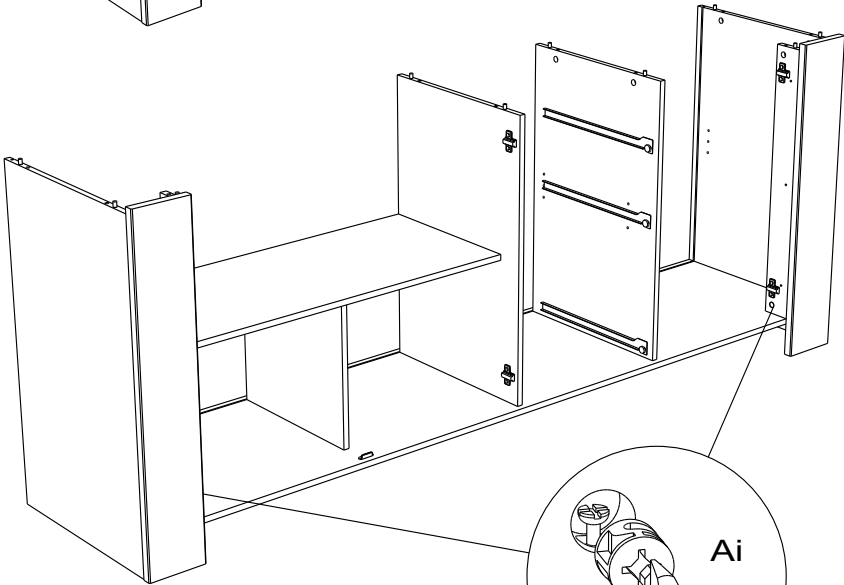
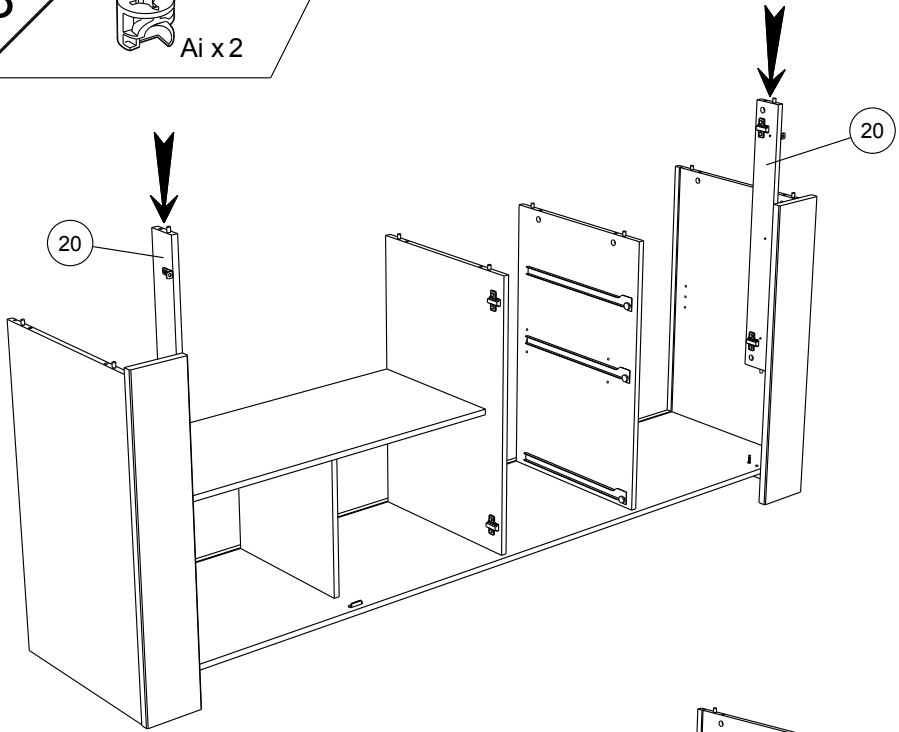

Ai x 2



24

VB x 6

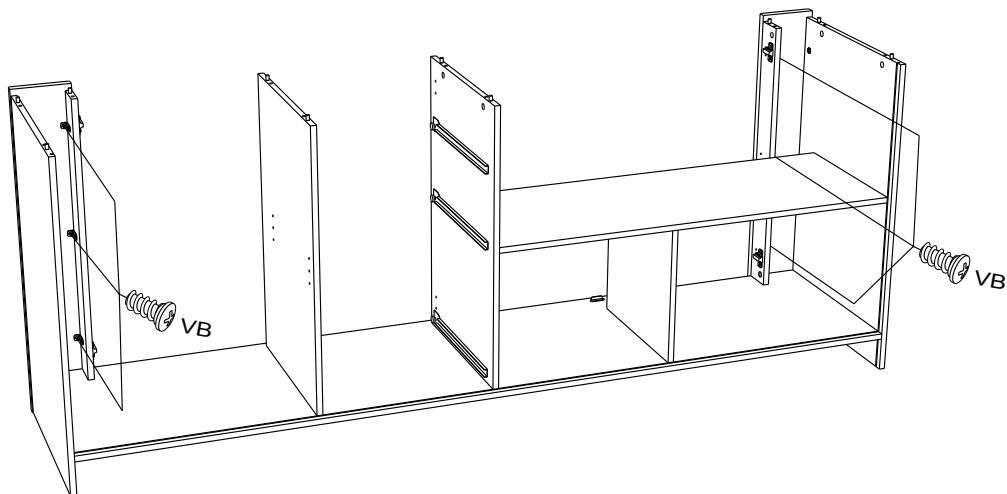

25

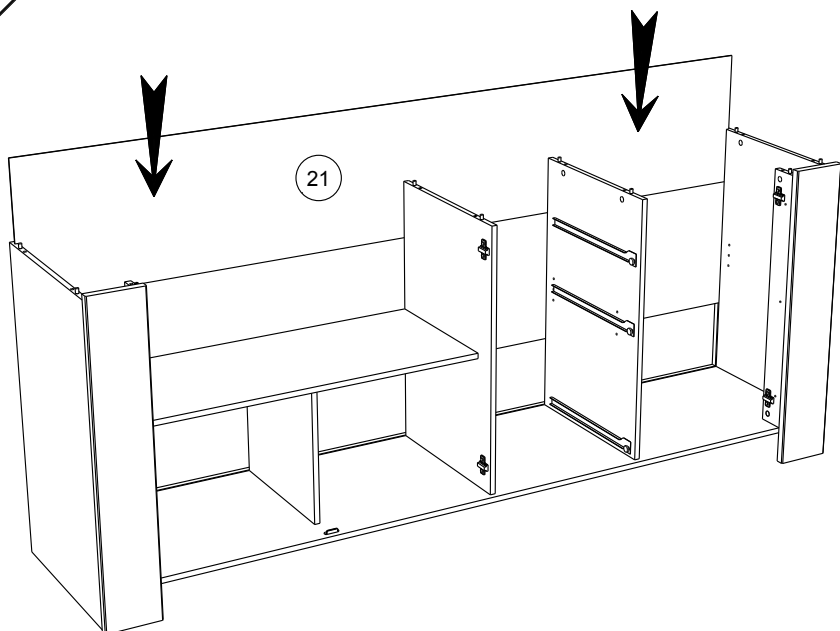

26



Ai x 10

22

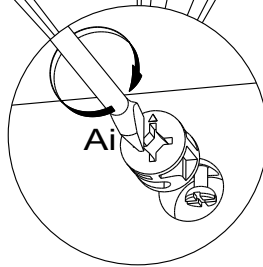
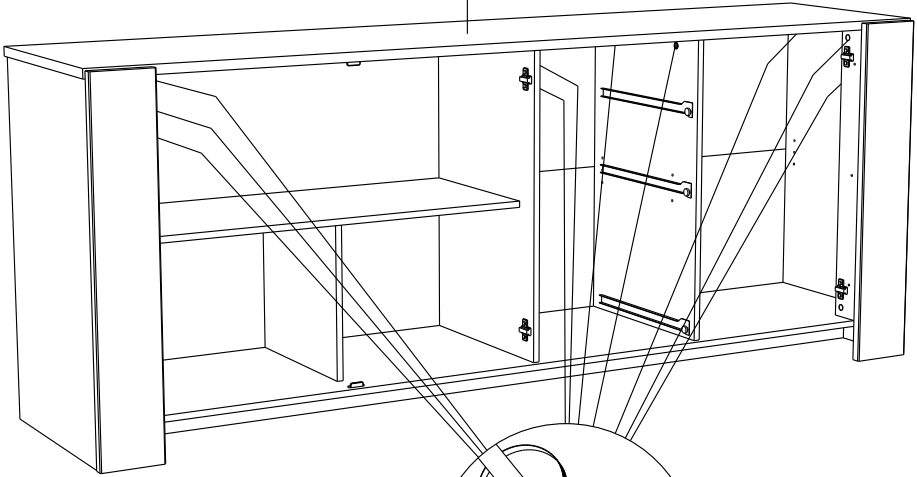

27



EP x2

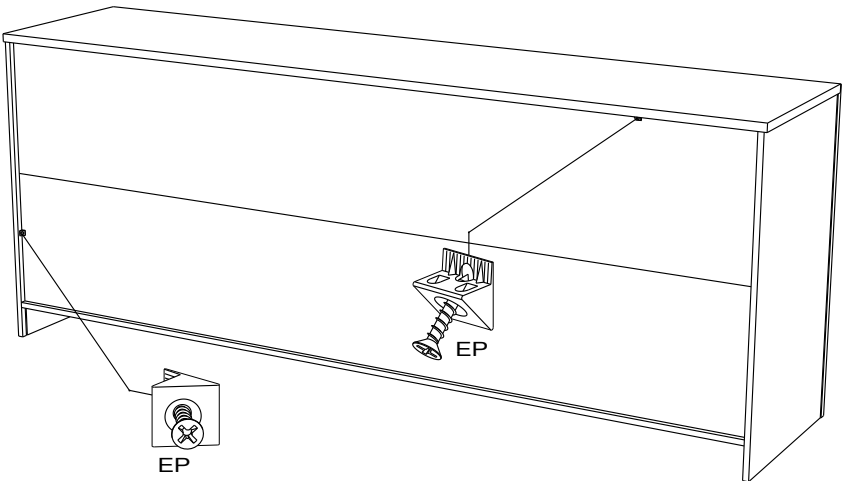

28

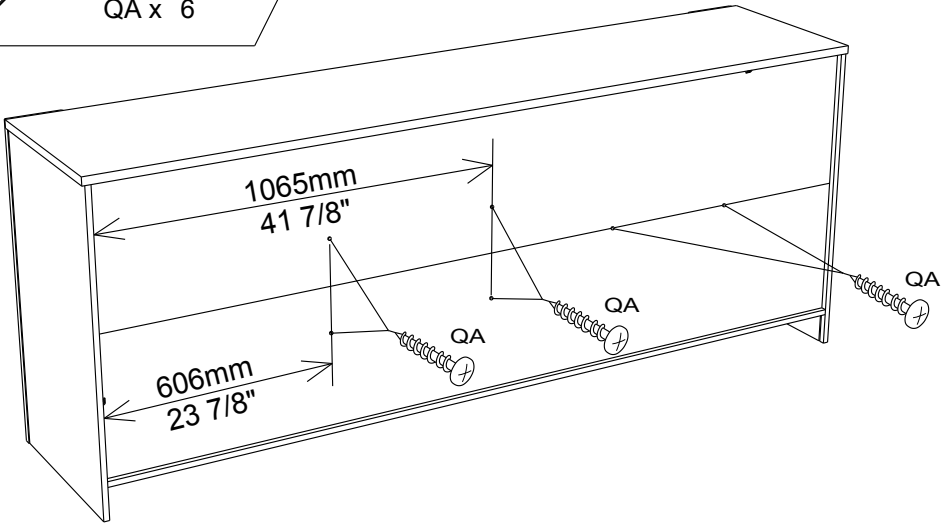
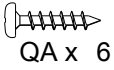

29

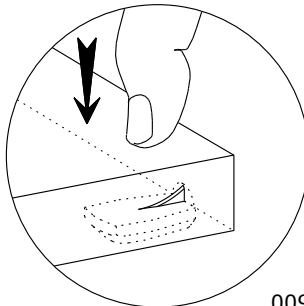
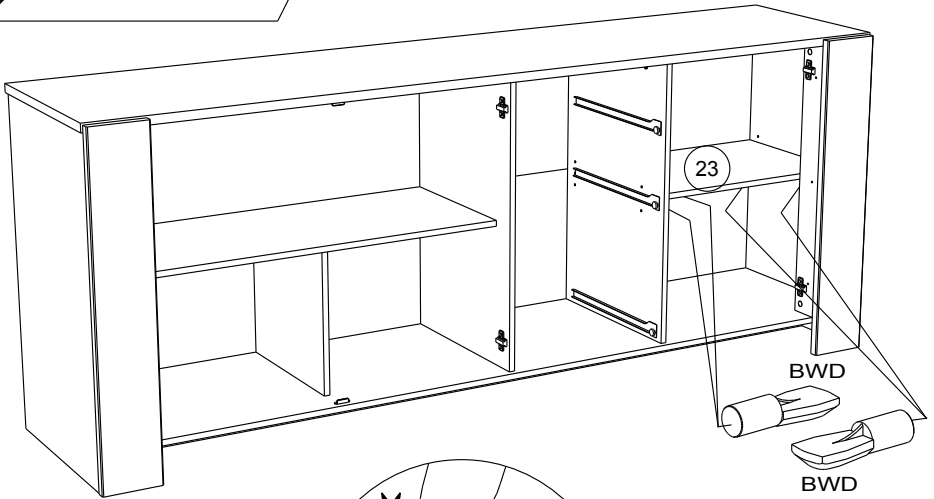

- FR OBLIGATOIRE:** Pour votre sécurité, fixation du meuble au mur.
Attention, la fixation doit être réalisée par une personne compétente car cela nécessite des chevilles et des vis adaptées à la nature de votre mur. (non fournies)
- EN OBLIGATORY:** For your safety, due to risk of overturning, this product must be used with the wall attachment device provided, this should be carried out by a competent person.
- DE OBLIGATORISCH:** Zu Ihrer Sicherheit, befestigen Sie das Möbel an der Wand.
Achtung: Diese Befestigung ist durch eine fachlich kompetente Person vorzunehmen.
Hierfür sind für die Bauweise Ihrer Wand geeignete Dübel einzusetzen.
- ES OBLIGATORIO:** Por su seguridad, fijar el mueble a la pared.
Advertencia: la fijación la ha de llevar a cabo por personal adecuado, ya que requiere el uso de tacos que se adapten al tipo de pared.
- PT OBRIGATORIO:** Para sua segurança, fixação do móvel ao muro.
Atenção: a fixação deverá ser efetuada por pessoa habilitada, visto que são necessárias cavilhas adaptadas ao tipo de parede.
- IT OBBLIGATORIO:** Avvertenza di sicurezza, il fissaggio del mobile a parete deve essere realizzato da una persona competente, in quanto l'operazione richiede l'impiego di tasselli adatti alla natura del muro.
- NL VERPLICHT:** Voor uw veiligheid, bevestiging van het meubel aan de muur.
Opgelet de bevestiging moet worden uitgevoerd door een bekwaam persoon daar dit voor uw type muur geschikte pluggen vereist.
- CZ POVINNÝ:** Z bezpečnostních důvodů, upevněte nábytek do zdi.
Pozor, upevnění je třeba svěřit kompetentní osobě, neboť vyžaduje hmoždinky vhodné pro vaši zed'.
- HU KÖTELEZŐ:** Az Ön biztonsága érdekében, a bútor falra rögzítése.
Figyelmeztetés : a rögzítés csak megfelelő szakképesítéssel rendelkező személy által végezhető el, mert a rögzítéshez a falnak megfelelő csavarokra van szükség.
- PL OBOWIĄZKOWY:** Dla bezpieczeństwa, mocowanie mebla do ściany.
Uwaga, mocowanie musi zostać wykonane przez osobę kompetentną, ponieważ wymaga to zastosowania kółków dostosowanych do rodzaju ściany.
- SK POVINNÉ:** Z bezpečnostných dôvodov, nábytok upevnite k stene.
Dbajte na to, aby upevnenie vykonala kompetentná osoba, pretože pri upevňovaní sa vyžadujú kolíky vhodné do materiálu, z ktorého je stena vyrobená.
- EL ΥΠΟΧΡΕΩΤΙΚΟΣ :** Για την ασφάλειά σας στερέωση των επίπλων στον τοίχο.
Προσοχή, η στερέωση πρέπει να γίνεται από ικανό άτομο, καθώς απαιτούνται σφήνες προσαρμοσμένες στη φύση του τοίχου σας.

AR واجب : لسلامتك الشخصية, تثبيت قطعة الأثاث على الحائط
تحذير، يجب أن يقوم شخص متخصص بعملية التثبيت على الحائط إذ أنها تتطلب اسفينا معيناً يتوافق مع طبيعة الحائط نفسه.

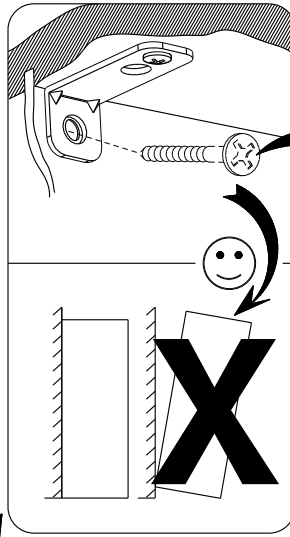

NON INCLUE.
NO INCLUIDO.
NOT INCLUDED.
WERDEN NICHT.
MITGELIEFERT.
NIET INBEGREPEN.
DAHIL DEGIL.

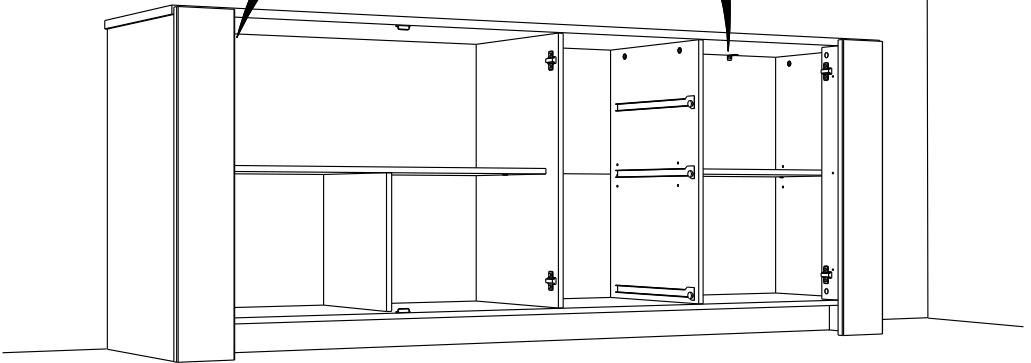

31

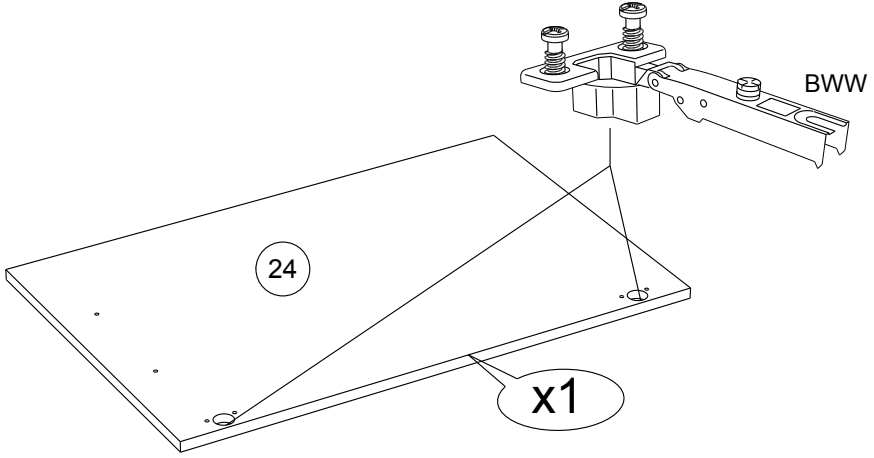
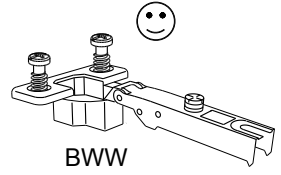
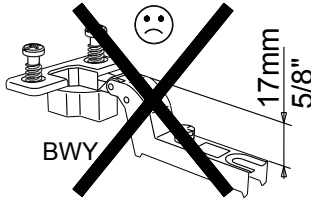
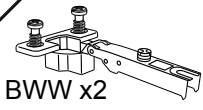

32

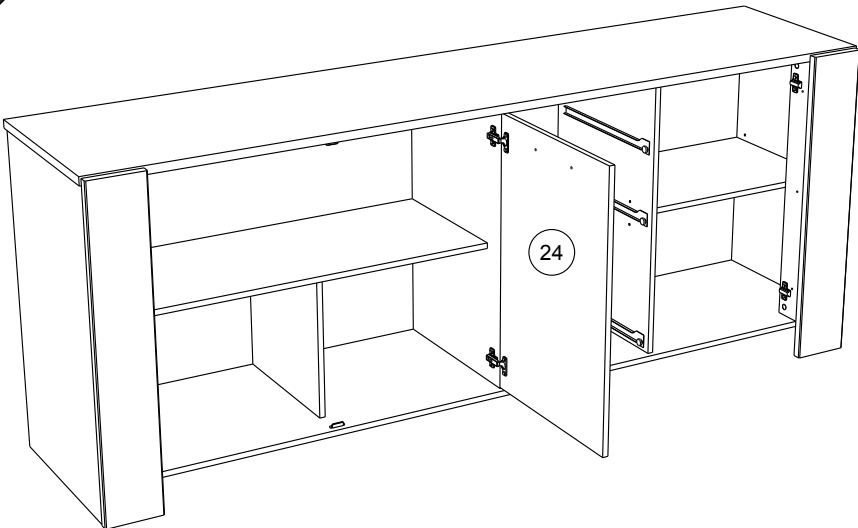

33

BWY x2

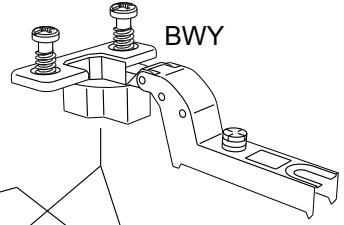
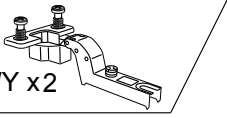

24

34

BWY x2

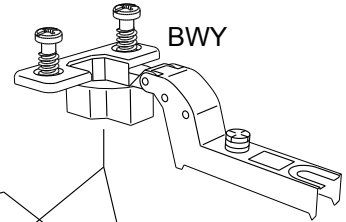
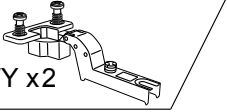

25

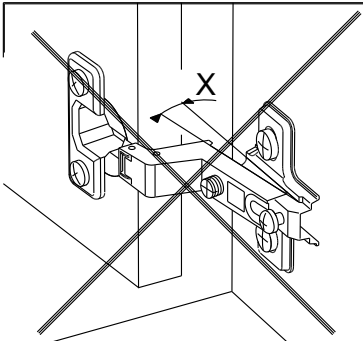
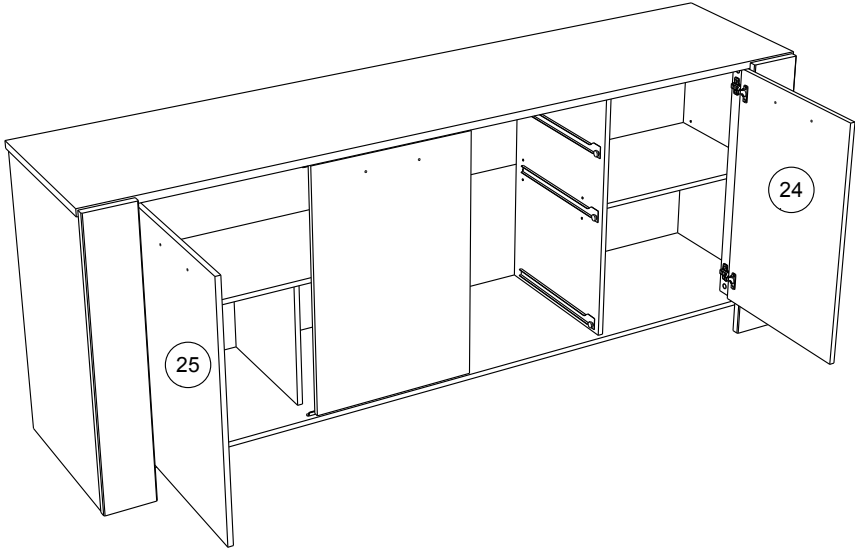

MONTAGE

- Ⓒ GB LEAFLET
- Ⓓ D AUFBAUANLEITUNG
- Ⓔ E MONTAJE
- ⒫ P MONTAGEM
- Ⓖ I MONTAGGIO
- Ⓗ NL MONTAGE

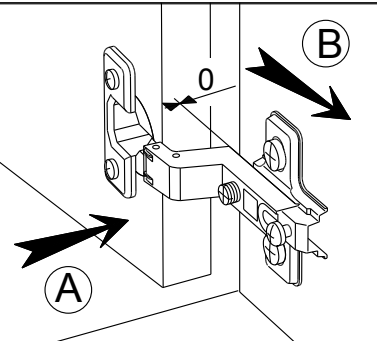

REGLAGE Ⓒ ADJUSTING Ⓔ AJUSTER Ⓖ AGGIUSTAMENTO
 Ⓓ ANPASSUNG ⒫ REGULACAO Ⓗ AFSTELLING

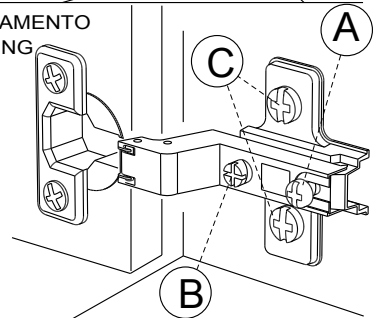
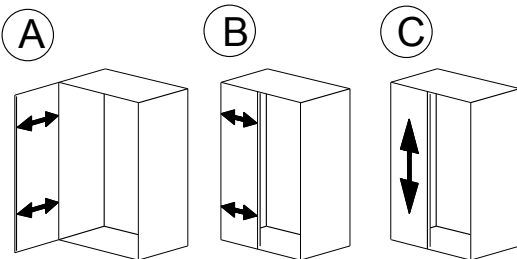

36



X3

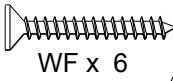

WF x 6

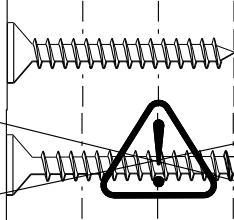
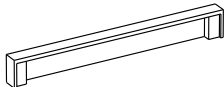
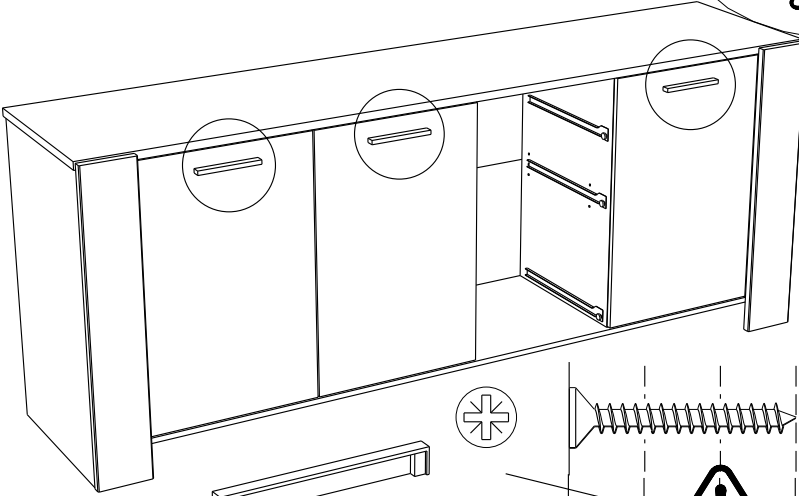
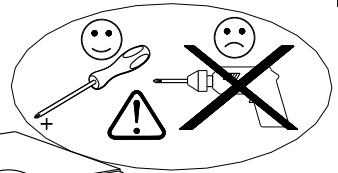

WF x 6

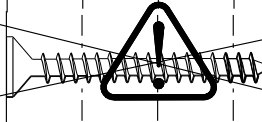

VAF12 x 6

37



AFM x 2

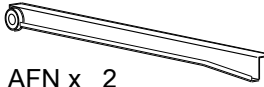

AFN x 2

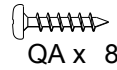

QA x 8

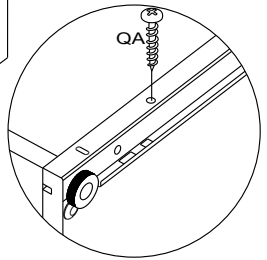
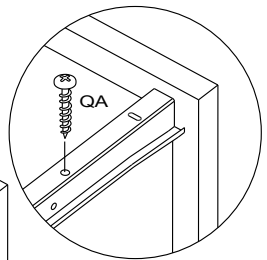
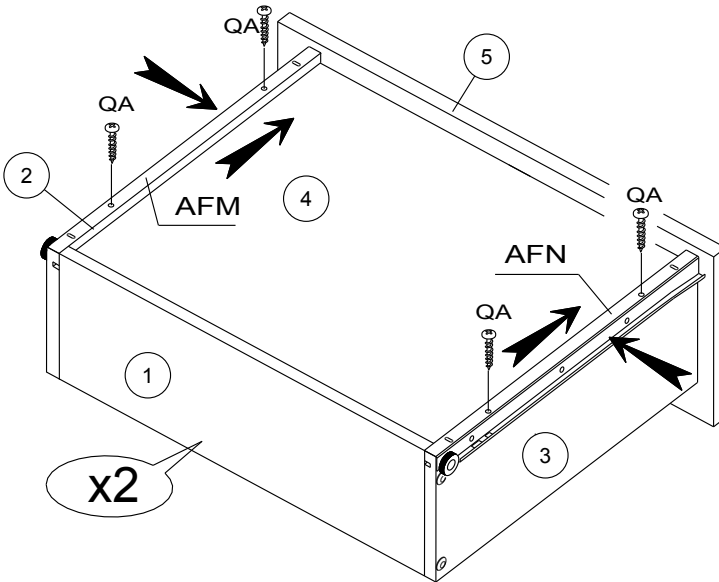

38



AFM x 1

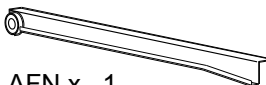

AFN x 1

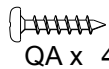

QA x 4

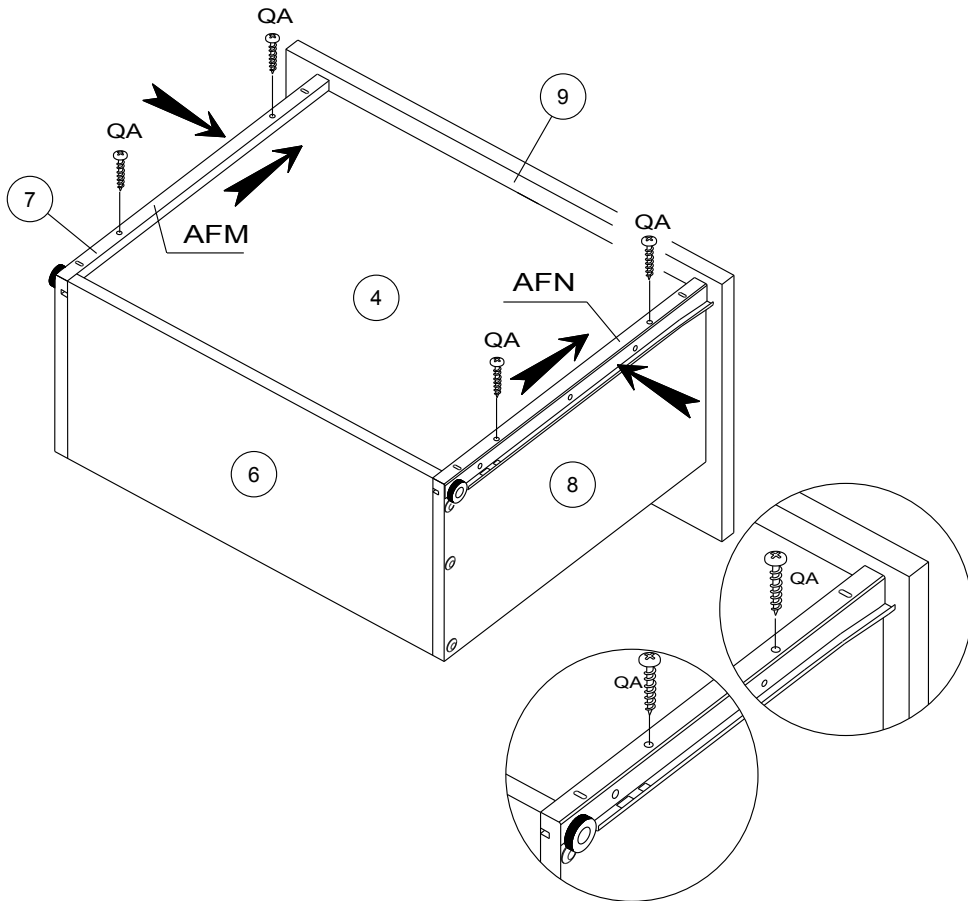

39

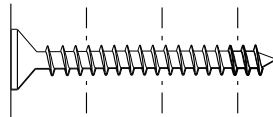
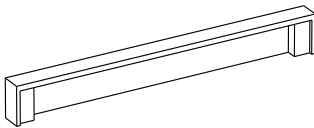
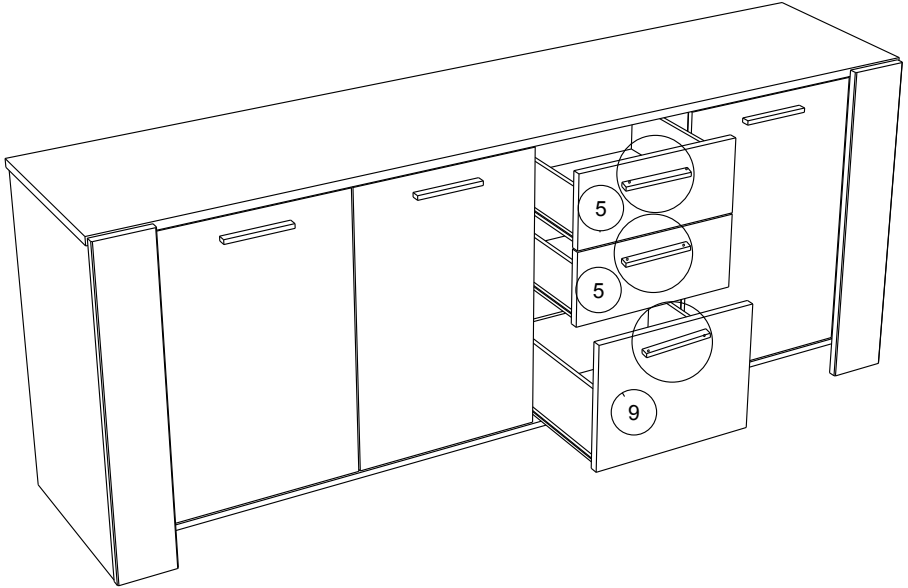
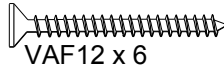
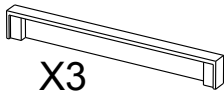

VAF12 x 6

